

**COMPRESSOR**

Displacement (cm <sup>3</sup> )	23.2
Diameter (mm)	34.93
Stroke (mm)	24.2
Net Weight (Kg)	17
Oil type	ISO VG 46 ESTER
Oil charge (cm <sup>3</sup> )	500

**MOTOR**

Approximate Power (CV)	5/8
Voltage/Frequency (V/Hz)	220V 50Hz
Voltage range (V)	187-264
Code	82,197
Type	CSIR
Phase number	1 PH
Locked rotor current (A)	26.0
Main W. resist. at 25°C (Ω)	2.45
Start W. resist. at 25°C (Ω)	25.9

**APPLICATION**

Application	High/Mid. back pressure
Refrigerant	R134a
Evaporating (°C)	-25 to 10
Expansion	Capillar/Valve
Comp. cooling	Fan cooled
Max. ambient temp. (°C)	43

**NOMINAL PERFORMANCE**

	<b>CYCLE C</b>	<b>CYCLE D</b>
Cooling capacity (W)	1730	2070
Input power (W)	913	950
EER (kcal/Wh)	1.62	1.87
COP (W/W)	1.89	2.17
Current (A)	5.64	5.79

**TEST CONDITIONS**

Evaporating temp. (°C)	5.0	7.2
Condensing temp. (°C)	55.0	55.0
Liq.t. entering expan. (°C)	55.0	46.0
Ambient t. and return (°C)	32.0	35.0
Tens/Freq (V/Hz)	220V 50Hz	220V 50Hz

**ELECTRICAL COMPONENTS**

Relay	9660 A 180	MTRP 16
Pick-Up (A)	16,70	16,70
Drop-Out (A)	14,00	14,00
Protector	MRA38152	T0260/G.
Current (A)	27.5	22.0
Time check (seg)	2,8-5,2	7,5-14
Disc temp. (Open/Close) (°C)	105.0 / 52.0	105.0 / 52.0
Starting capacitor (μF/V)/F/V)	72- 88 / 330	

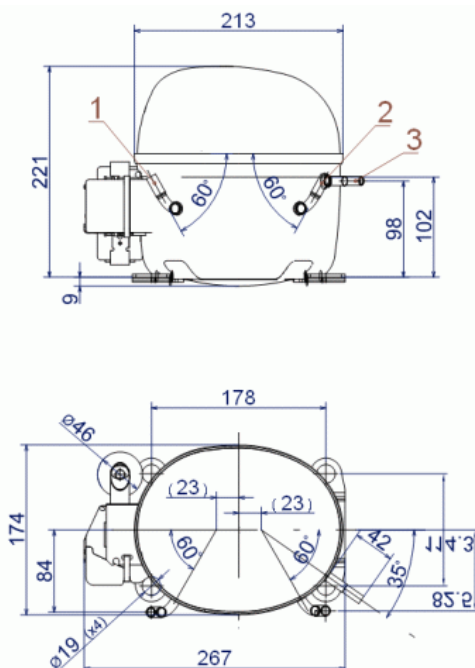
**DIMENSIONS AND ELECTRICAL DIAGRAM**

	<b>DESIGNATION</b>	<b>INTERNAL DIAM. (MM)</b>
1	Service	8,1
2	Suction	8,1
3	Discharge	6,5

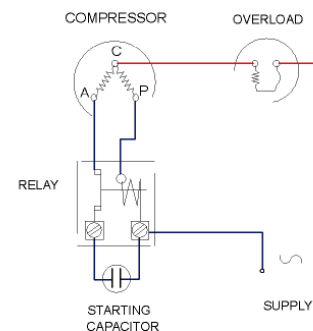
**CSIR**

**TEST CONDITIONS**

Voltage/frequency	220V 50Hz
Ambient t. and return	35 °C
Liq.t. entering expan.	Subcooling 9 K

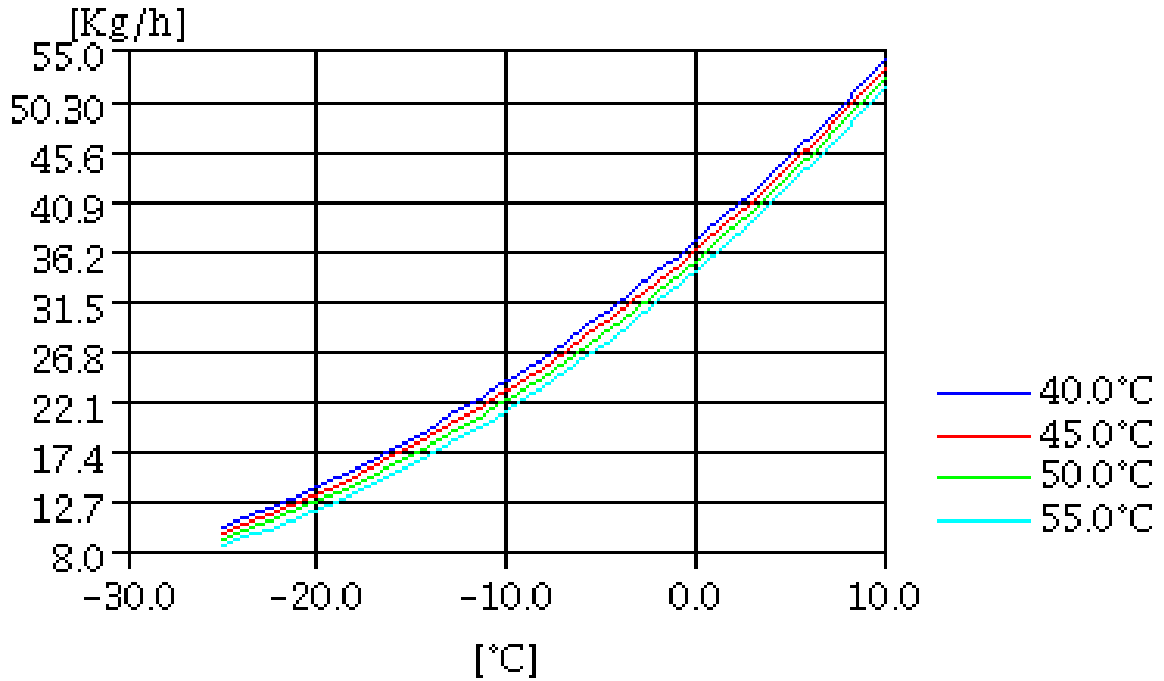
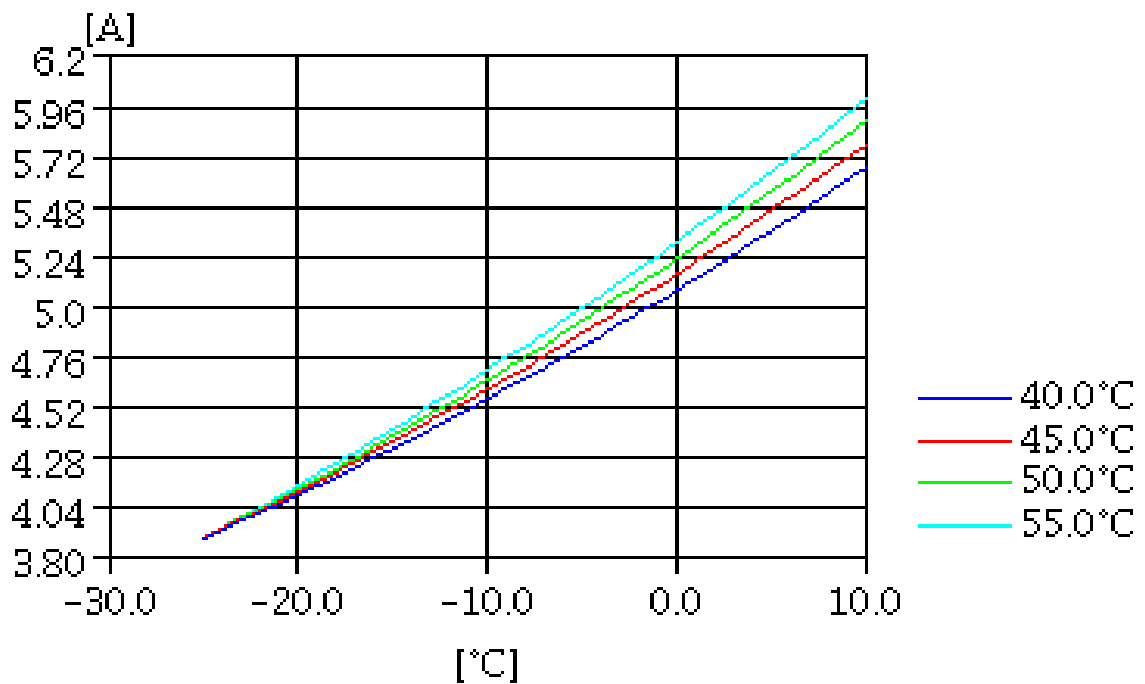
**MASS FLOW**

**CONSUMPTION**

**TEST CONDITIONS**

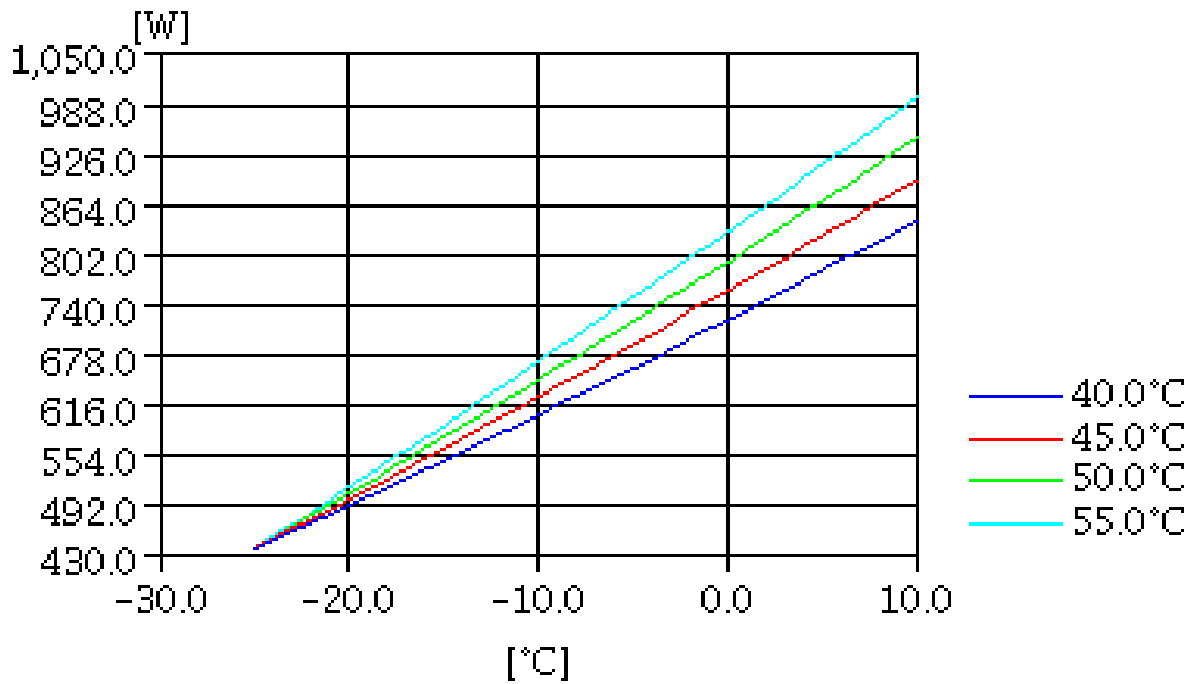
Voltage/frequency	220V 50Hz
Ambient t. and return	35 °C
Liq.t. entering expan.	Subcooling 9 K

**INPUT W**

**COOLING CAPACITY**
