

Model

Designation	HMK95AA	220-240V/50Hz ~	Sales code:	CDO00164
-------------	----------------	-----------------	-------------	-----------------

Compressor design

Oil type	Mineral	Refrigerant(s)	R600a
Oil viscosity	7,2cST	Displacement	9,6cm ³ / 0,59cu.in
Oil quantity	162cm ³ / 5,5fl.oz	Compressors on pallet	100
Refr. charge - tech. limit	150g / 5,3oz		
Free gas volume comp.	1500cm ³ / 50,7fl.oz		
Weight	7,9kg / 17,4lbs		
Motor protection	external		
Winding resistance main	21,1Ω (at 25°C)		
Winding resistance aux	19,1Ω (at 25°C)		
Max. winding temp.	130°C / 266°F		
Max. discharge temp.	120°C / 248°F		



General - Configurations with HMK95AA

	Conf. 1
Motorconfiguration	RSIR
Power supply (nominal)	220-240V/50Hz
Number of phases	1
Voltage range	187-264V
Approvals	VDE
Starting torque	LST
Note	- / -

Applications with HMK95AA

	Conf. 1
Refrigerant	R600a
Application	LBP
System cooling	static
Hot gas defrost	- / -
Long interval pull down	- / -

Electrical data - Configurations with HMK95AA

	Conf. 1
Starting device type	PTC
Run capacitor	- / -
Start capacitor	- / -
LRA (locked rotor amps / 4s)	4,6A
RLA (rated load amps / 1s)	1A
Cut in current	10,1A
IP class	21

Model

Designation	HMK95AA	220-240V/50Hz ~	Sales code:	CDO00164
-------------	----------------	-----------------	-------------	-----------------

Compressor dimensions

Housing	A Height	166mm / 6,54in
	B Height	159mm / 6,26in
	C Length shell	194mm / 7,64in
	D Length w. cover	238mm / 9,37in
	E Width	151mm / 5,94in

Connectors		Suction	Discharge	Process
		X	Y	Z
Diameter	[mm]	øi 6,1-6,2	øi 5,1-5,2	øo 5,92-6,08
(i:inside, o:outside)	[in]	øi 0,24-0,24	øi 0,2-0,2	øo 0,23-0,24
Material		copper	copper	copper
Horizontal angle	±2°	45°	13°	0°
Vertical angle	±2°	30°	40°	145°
Position l/h/w	[mm]	120/72/62	112/106/62	-140/136/70
	[in]	4,7/2,8/2,4	4,4/4,2/2,4	-5,5/5,4/2,8
Straight tube l.	[mm]	14	14	75
	[in]	0,5	0,5	3

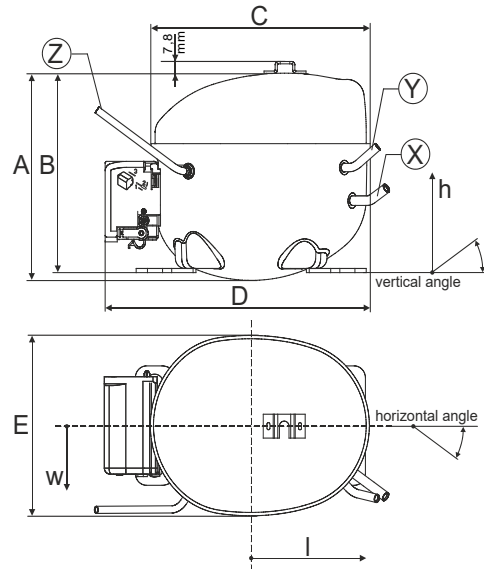

Compressor fixation

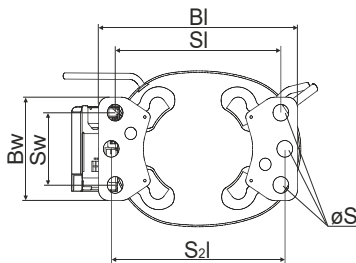

Baseplate	[mm]	[inch]
BI	204	8.03
Bw	100	3.94
Small holes		
SI	170	6.7
Sw	70	2.76
S2l	178	7
øS	ø 16	ø 0.63

Bolt joint

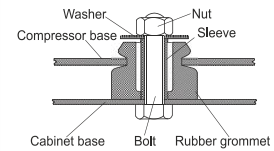

Snap-on

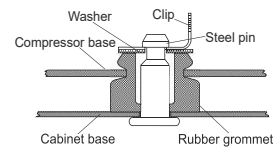

Mounting accessories

'4ZN' with rubber grommet	order code	772N
'4ZN' with rubber grommet and sleeve for M6		768N
Bolt joint kit		4ZN + 118-1917 (18)
'4ZN' with Snap on kit		776N

Application notes

Various options of housing are possible (dip-tray fixture) - please contact SECOP-Sales.
 Various options of connectors are possible - please contact SECOP-Sales.

Model

Designation	HMK95AA	220-240V/50Hz	Conf. 1	Sales code:	CDO00164
-------------	----------------	----------------------	----------------	-------------	-----------------

Configuration

Motorconfiguration	RSIR
Power supply (nominal)	220-240V/50Hz 1~
Refrigerant	R600a
Application	LBP
Voltage range	187-264V
Starting torque	LST
Approvals	VDE

Electrical accessories / wiring diagram

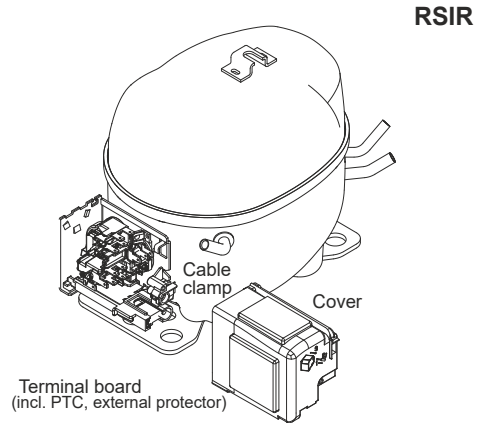

Ambient temperatures / system cooling

Ambient temperature min.:	10°C / 50°F
Ambient temperature max.:	43°C / 110°F

System cooling (n/a: outside limits)			
T ambient	LBP	MBP	HBP
32°C / 90°F	static	n/a	n/a
38°C / 100°F	static	n/a	n/a
43°C / 110°F	static	n/a	n/a

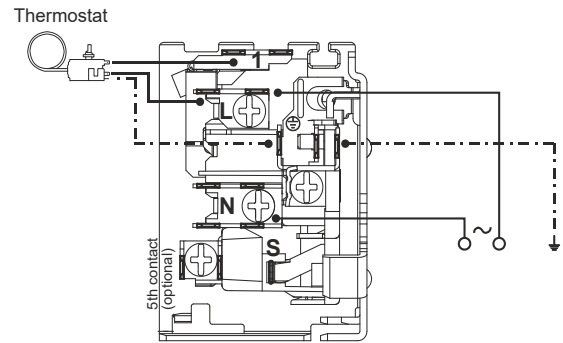

8858-6

Operation pressure range

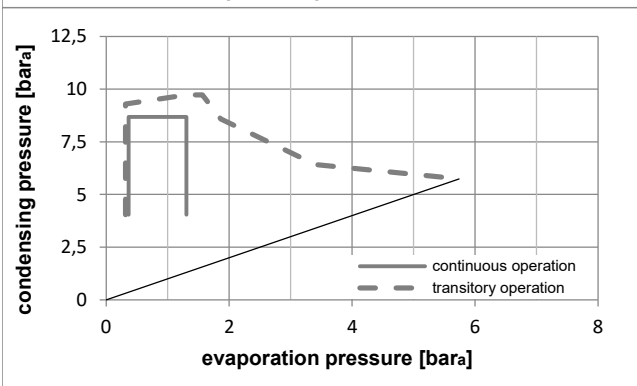
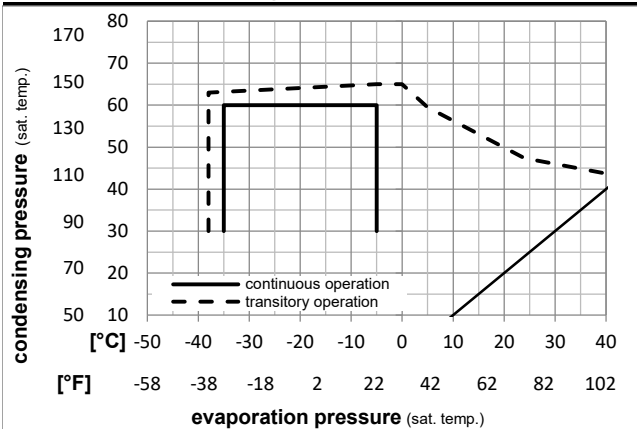

Components

- . terminal board (PTC,4.8mm,K100) ZA F5
- . motor protector BDG AE 18 Fu x AE18FUX
- . cover + clamp + screws (Nr. 4ZN) 16168000
- . evaporation tray (optional) 113188_

Alternative components

- . terminal board (PTC,6.3mm,K100) DA F5
- . motor protector BDG AE 18 Fu x AE18FUX
- . cable clamp (screws not included) 113410_
- . cover 157595_
- . evaporation tray (optional) 113188_

Model

Designation	HMK95AA	220-240V/50Hz	Conf. 1	Sales code:	CDO00164
-------------	----------------	----------------------	----------------	-------------	-----------------

Optimization + standard conditions

220V/50Hz, RSIR, static, VDE

		Evaporating pressure (saturation temperature)				Condensing pressure (saturation temperature)					Power consumption				
											Current consumption				
											P1	I	Ref. mass flow		
													m		
		pe	pc	RGT	Tliq	[W]	[Btu/h]	[kcal/h]	COP	EER	[kcal/Wh]	[W]	[A]	[kg/h]	
[°C]	-23,3	54,4	32,2	32,2	166,9	570	143,6	1,53	5,22	1,31	109,3	0,76	1,79	ASHRAE LBP	
[°F]	-10	130	90	90											
[°C]	-25	55	32	55	125,0	427	107,6	1,19	4,07	1,02	105,0	0,74	1,63	cecomaf LBP	
[°F]	-13	131	89,6	131											
[°C]	-35	40	20	40	72,9	249	62,7	0,99	3,38	0,85	73,7	0,63	0,89	EN12900 LBP	
[°F]	-31	104	68	104											
[°C]	-23,3	48,9	4,44	48,9	134,4	459	115,7	1,28	4,38	1,10	104,7	0,75	1,96	ARI540 LBP	
[°F]	-10	120	40	120											
[°C]	-23,3	40,6	32,2	32,2	175,0	598	150,6	1,77	6,04	1,52	99,0	0,74	1,88	AHAM LBP	
[°F]	-10	105	90	90											
[°C]	-35	45	32	45	72,5	248	62,4	0,96	3,29	0,83	75,4	0,62	0,86	opt	
[°F]	-31	113	89,6	113											

Performance tables

220V/50Hz, RSIR, static, VDE

	pe		Cooling capacity			COP		EER		P1	I	m
	[°C]	[°F]	[W]	[Btu/h]	[kcal/h]	[W/W]	[Btu/Wh]	[kcal/Wh]	[W]	[A]	[kg/h]	
[°C / °F]	-35	-31	72,5	248	62,4	0,96	3,29	0,83	75,4	0,62	0,86	
cond. pressure	-30	-22	104,4	357	89,9	1,21	4,12	1,04	86,5	0,67	1,24	
pc= 45/113	-25	-13	141,8	484	122,1	1,45	4,94	1,25	98,0	0,73	1,69	
return gas temp.	-23,3	-10	155,8	532	134,1	1,53	5,22	1,31	102,0	0,75	1,86	
RGT= 32/90	-20	-4	184,7	631	158,9	1,68	5,75	1,45	109,7	0,78	2,20	
liquid temp	-15	5	233,0	796	200,5	1,92	6,56	1,65	121,2	0,84	2,78	
Tliq= 45/113	-5	23	345,9	1181	297,7	2,41	8,23	2,08	143,5	0,96	4,15	
[°C / °F]	-35	-31	66,7	228	57,4	0,85	2,89	0,73	78,9	0,60	0,87	
cond. pressure	-30	-22	92,9	317	79,9	1,02	3,47	0,87	91,4	0,67	1,21	
pc= 55/131	-25	-13	125,0	427	107,6	1,19	4,07	1,02	105,0	0,74	1,63	
return gas temp	-23,3	-10	137,3	469	118,1	1,25	4,27	1,08	109,8	0,77	1,79	
RGT= 32/90	-20	-4	163,0	557	140,3	1,36	4,66	1,17	119,5	0,81	2,13	
liquid temp	-15	5	207,0	707	178,2	1,54	5,25	1,32	134,8	0,89	2,71	
Tliq= 55/131	-5	23	312,6	1067	269,0	1,88	6,41	1,61	166,6	1,04	4,11	