

Technical Data Sheet

ENGINEERING
TOMORROW



Compressor model **ML60TB**
Voltage **220-240V 50Hz ~1**
Refrigerant **R404A**

APPLICATION

COMPRESSOR

MOTOR

Application	High-Medium Back Pressure	Displacement	5,68 cm ³	Nominal Power	1/4 hp
Refrigerant	R404A	Diameter	22,00 mm	Voltage/Frequency	220-240V 50Hz
Evaporating Temp.	-25,0 °C to 10,0 °C	Stroke	14,92 mm	Voltage range	198-255 V
Expansion	Capillar/Valve	Net Weight	9,29 Kg	Type	CSIR
Comp. Cooling	Fan cooled	Oil type	ISO VG 32 ESTER	Phase number	1 PH
Max. ambient temp.	43,0 °C	Oil charge	295 cm ³	Locked Rotor Amps (LRA)	10,60 A
				Max. Cont. Current (MCC)	3,60 A
				Main W. resist. at 25°C	10,00 Ω
				Start W. resist. at 25°C	31,50 Ω

NOMINAL PERFORMANCE

	ASHRAE	CECOMAF
Cooling Capacity	700 kCal/h	643 W
COP	1,85 W/W	1,50 W/W
EER	1,59 kCal/Wh	1,30 kCal/Wh
Input Power	440 W	427 W
Current	2,45 A	2,39 A

APPROVALS



TEST CYCLE CONDITIONS

	ASHRAE HMBP (D)	CECOMAF HMBP (C)
Evaporating temp. (T _e)	7,2 °C	5,0 °C
Condensing temp. (T _c)	55,0 °C	55,0 °C
Liquid temp. (T _{liq.})	46,0 °C	55,0 °C
Ambient temp. (T _{amb.})	35,0 °C	32,0 °C
Suction temp. (T _{suction})	35,0 °C	32,0 °C
Voltage/Frequency	220 V 50 Hz	220 V 50 Hz

ELECTRICAL COMPONENTS

	Option 1	Option 2		
Starting capacitor	47- 56 μF 330 V			
Relay	Option 1	Option 2		
Reference	2014 131.	QLZ-5.3A		
Pick-Up	5,30 A	5.30 A		
Drop-Out	4,50 A	4.50 A		
Protector	Option 1	Option 2		
Reference	T0168	MRT38AMK		
Current	9,50 A	10,00 A		
Time check	7,5-14 seg	7,5-14 seg		
Disc temp. (Open/Close)	105,00 / 61,00 °C	105,00 / 61,00 °C		

Technical Data Sheet

ENGINEERING
TOMORROW



ASHRAE

Tc °C	Te °C	Cooling Capacity kCal/h	Consumption W	Current A	COP W/W	EER kCal/Wh
40	-25	233	218	1,62	1,24	1,07
40	-20	304	240	1,68	1,47	1,27
40	-15	388	264	1,76	1,71	1,47
40	-10	484	288	1,84	1,95	1,68
40	-5	593	314	1,93	2,20	1,89
40	0	714	340	2,03	2,44	2,10
40	5	847	368	2,13	2,68	2,31
40	7,2	910	380	2,18	2,79	2,39
40	10	993	396	2,25	2,92	2,51

45	-25	210	220	1,63	1,11	0,95
45	-20	274	245	1,70	1,30	1,12
45	-15	350	271	1,78	1,50	1,29
45	-10	439	299	1,87	1,71	1,47
45	-5	541	327	1,98	1,92	1,65
45	0	654	356	2,09	2,14	1,84
45	5	781	386	2,21	2,35	2,02
45	7,2	840	400	2,27	2,44	2,10
45	10	919	418	2,35	2,56	2,20

50	-25	188	223	1,63	0,98	0,84
50	-20	244	250	1,72	1,13	0,97
50	-15	313	279	1,81	1,30	1,12
50	-10	395	309	1,91	1,48	1,28
50	-5	489	340	2,03	1,67	1,44
50	0	595	372	2,15	1,86	1,60
50	5	714	405	2,29	2,05	1,76
50	7,2	770	420	2,36	2,13	1,83
50	10	845	439	2,45	2,24	1,92

55	-25	165	225	1,64	0,85	0,73
55	-20	214	256	1,73	0,97	0,84
55	-15	276	287	1,83	1,12	0,96
55	-10	350	320	1,95	1,27	1,09
55	-5	437	354	2,08	1,44	1,23
55	0	536	388	2,22	1,60	1,38
55	5	647	424	2,38	1,77	1,53
55	7,2	700	440	2,45	1,85	1,59
55	10	771	461	2,55	1,95	1,67

60	-25	143	228	1,65	0,73	0,63
60	-20	184	261	1,75	0,82	0,71
60	-15	239	295	1,86	0,94	0,81
60	-10	305	331	1,99	1,07	0,92
60	-5	385	367	2,13	1,22	1,05
60	0	476	404	2,29	1,37	1,18
60	5	580	443	2,46	1,52	1,31
60	7,2	630	460	2,55	1,59	1,37
60	10	697	482	2,65	1,68	1,45

CECOMAF

Tc °C	Te °C	Cooling Capacity W	Consumption W	Current A	COP W/W	EER kCal/Wh
40	-25	244	219	1,62	1,11	0,96
40	-20	320	241	1,69	1,33	1,15
40	-15	409	265	1,76	1,54	1,33
40	-10	510	290	1,84	1,76	1,52
40	-5	623	316	1,93	1,98	1,71
40	0	749	342	2,03	2,19	1,89
40	5	886	370	2,14	2,39	2,07
40	7,2	950	383	2,20	2,48	2,14
40	10	1.035	399	2,27	2,59	2,24

45	-25	217	221	1,63	0,98	0,85
45	-20	285	247	1,70	1,16	1,00
45	-15	365	273	1,79	1,34	1,15
45	-10	457	301	1,88	1,52	1,31
45	-5	561	329	1,98	1,70	1,47
45	0	677	359	2,10	1,89	1,63
45	5	805	389	2,22	2,07	1,79
45	7,2	865	403	2,28	2,15	1,85
45	10	945	421	2,36	2,25	1,94

50	-25	191	224	1,64	0,86	0,74
50	-20	250	252	1,72	0,99	0,86
50	-15	320	281	1,81	1,14	0,99
50	-10	403	311	1,92	1,30	1,12
50	-5	498	343	2,03	1,45	1,26
50	0	605	375	2,16	1,61	1,39
50	5	724	408	2,31	1,77	1,53
50	7,2	780	423	2,37	1,84	1,59
50	10	855	443	2,46	1,93	1,67

55	-25	165	226	1,64	0,73	0,63
55	-20	215	257	1,74	0,83	0,72
55	-15	276	289	1,84	0,95	0,83
55	-10	350	322	1,96	1,09	0,94
55	-5	435	356	2,09	1,22	1,06
55	0	533	391	2,23	1,36	1,18
55	5	643	427	2,39	1,50	1,30
55	7,2	695	443	2,47	1,57	1,35
55	10	765	464	2,57	1,65	1,42

60	-25	139	229	1,65	0,61	0,53
60	-20	179	262	1,75	0,68	0,59
60	-15	232	297	1,87	0,78	0,67
60	-10	296	333	2,00	0,89	0,77
60	-5	372	369	2,14	1,01	0,87
60	0	461	407	2,30	1,13	0,98
60	5	562	446	2,48	1,26	1,09
60	7,2	610	464	2,56	1,32	1,14
60	10	674	486	2,67	1,39	1,20



EN12900

X	Cooling Capacity (W)	Consumption (W)	Current (A)	Mass Flow (kg/h)
1	1.323,7214030896	218,8330888724	1,4400240143	26,290272144567
2	40,8635412866	1,2668847612	0,0021786883	0,93645715122666
3	-14,8753623679	3,3519744040	0,0153916989	-0,13951217810676
4	0,2292029353	0,0259262744	0,0003067069	0,010466850889953
5	-0,3852382620	0,1134850631	0,0005559775	-0,0026528346473223

Equation	$x_1 + x_2Te + x_3Tc + x_4Te^2 + x_5TeTc$
----------	---

COMPRESSOR DIMENSIONS

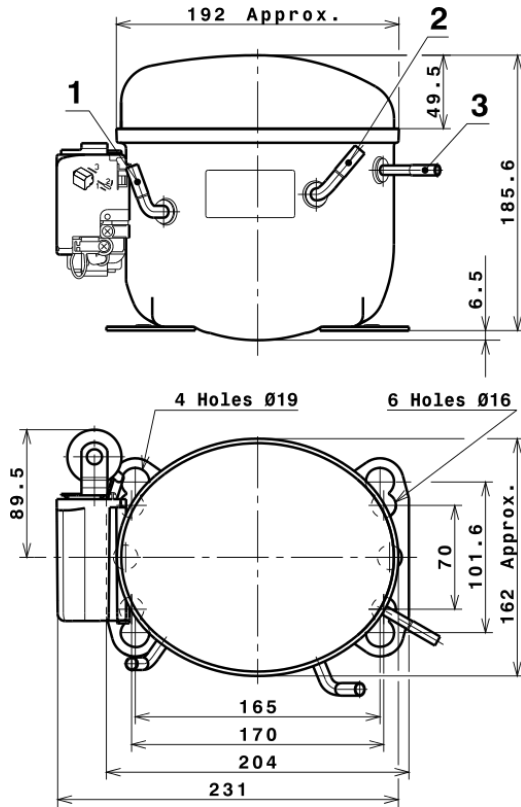

DESIGNATION INTERNAL DIAM.

DESIGNATION	INTERNAL DIAM.
1 Suction	6,5 mm
2 Service	6,5 mm
3 Discharge	4,9 mm

WIRING DIAGRAMS AND ELECTRICAL ASSEMBLY

CSIR CONNECTION (L, P ranges)

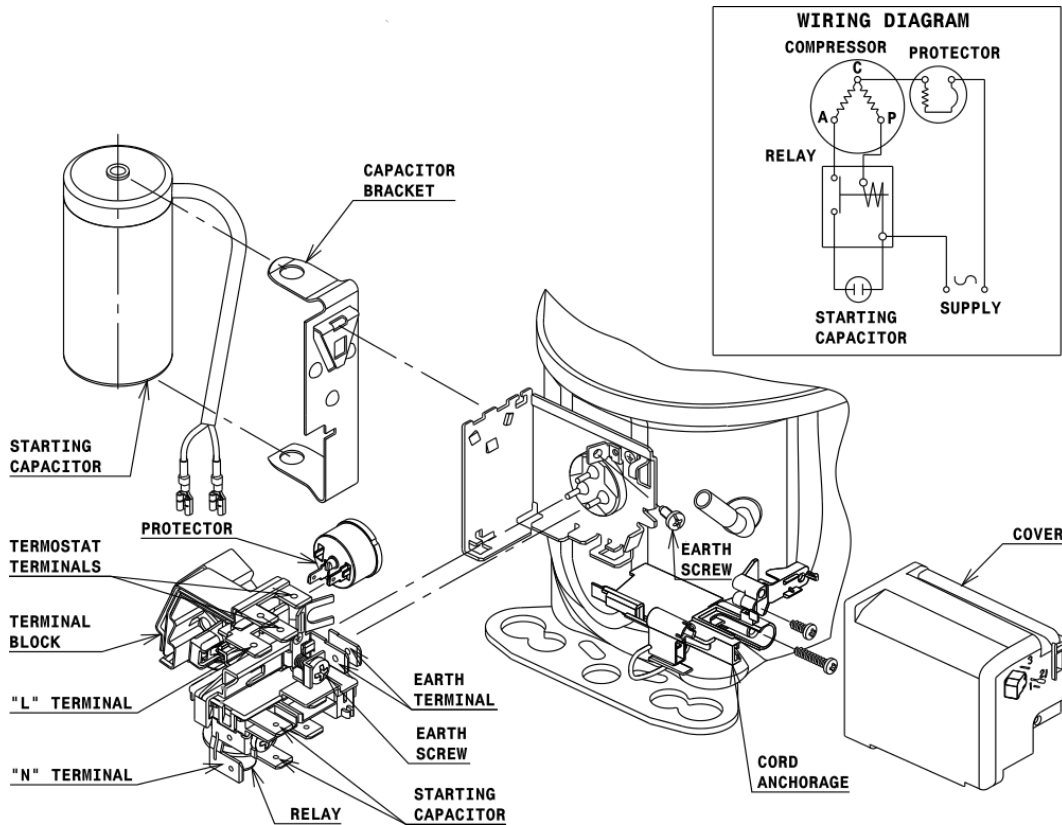

FIXINGS

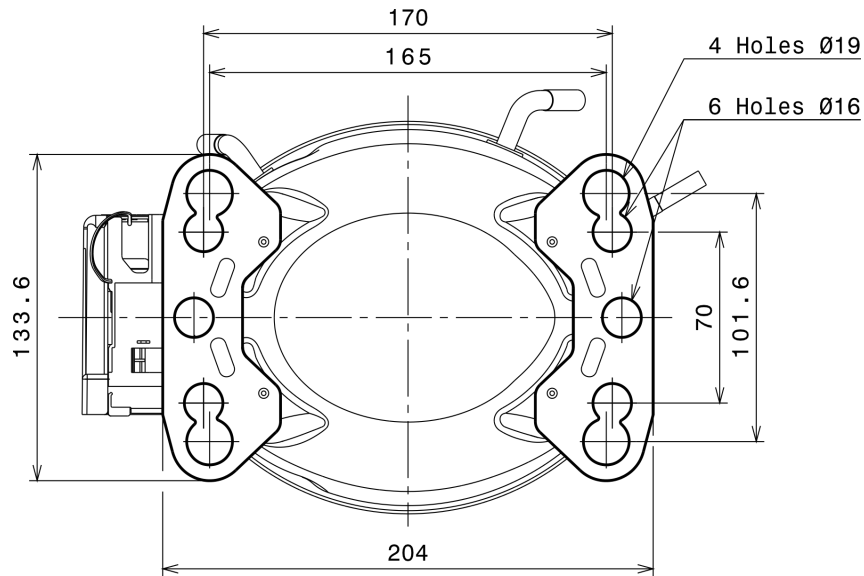

SILENT BLOCKS (MOUNTING ACCESSORIES)

STANDARD

$\varnothing 16$ holes (170x70 net)

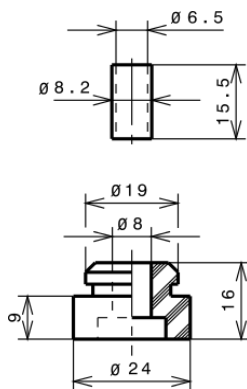

AMERICAN FEET

$\varnothing 19$ holes (165x101.6 net)

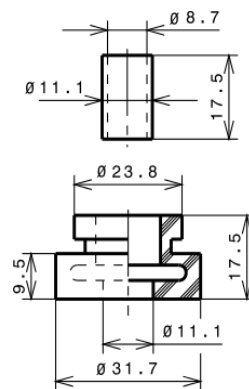

SNAP-ON

$\varnothing 16$ holes (170x70 net)

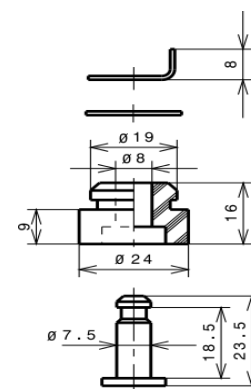

SOA

SOA R404A HMBP

