

## AC axial fan

sickle-shaped blades (S series)

**ebm-papst Mulfingen GmbH & Co. KG**

Bachmühle 2 · D-74673 Mulfingen

Phone +49 7938 81-0

Fax +49 7938 81-110

info1@de.ebmpapst.com

www.ebmpapst.com

Limited partnership · Headquarters Mulfingen

Amtsgericht (court of registration) Stuttgart · HRA 590344

General partner Elektrobau Mulfingen GmbH · Headquarters Mulfingen

Amtsgericht (court of registration) Stuttgart · HRB 590142

**Nominal data**

Type	A2E250-AL06-01		
Motor	M2E068-CF		
Phase		1~	1~
Nominal voltage	VAC	230	230
Frequency	Hz	50	60
Method of obtaining data		fa	fa
Valid for approval/standard		CE	CE
Speed (rpm)	min <sup>-1</sup>	2450	2600
Power consumption	W	115	150
Current draw	A	0.51	0.66
Capacitor	µF	3	3
Capacitor voltage	VDB	400	400
Capacitor standard		S0 (CE)	S0 (CE)
Max. back pressure	Pa	120	85
Max. back pressure	in. wg	0.48	0.34
Min. ambient temperature	°C	-25	-25
Max. ambient temperature	°C	65	50
Starting current	A	0.88	0.87

ml = Max. load · me = Max. efficiency · fa = Free air · cs = Customer specification · ce = Customer equipment  
Subject to change



### Technical description

Weight	1.8 kg
Size	250 mm
Motor size	68
Rotor surface	Painted black
Blade material	Sheet steel, painted black
Number of blades	7
Airflow direction	V
Direction of rotation	Counterclockwise, viewed toward rotor
Degree of protection	IP44; installation- and position-dependent as per EN 60034-5
Insulation class	"B"
Moisture (F) / Environmental (H) protection class	H1
Max. permitted ambient temp. for motor (transport/storage)	+ 80 °C
Min. permitted ambient temp. for motor (transport/storage)	- 40 °C
Installation position	Shaft horizontal or rotor on bottom; rotor on top on request
Condensation drainage holes	On rotor side
Mode	S1
Motor bearing	Ball bearing
Touch current according to IEC 60990 (measuring circuit Fig. 4, TN system)	< 0.75 mA
Motor protection	Thermal overload protector (TOP) internally connected
With cable	Variable
Protection class	I (with customer connection of protective earth)
Conformity with standards	EN 60034-1; EN 60204-1; EN 60335-1; CE; UKCA
Approval	CCC; EAC

# AC axial fan

sickle-shaped blades (S series)

## Product drawing

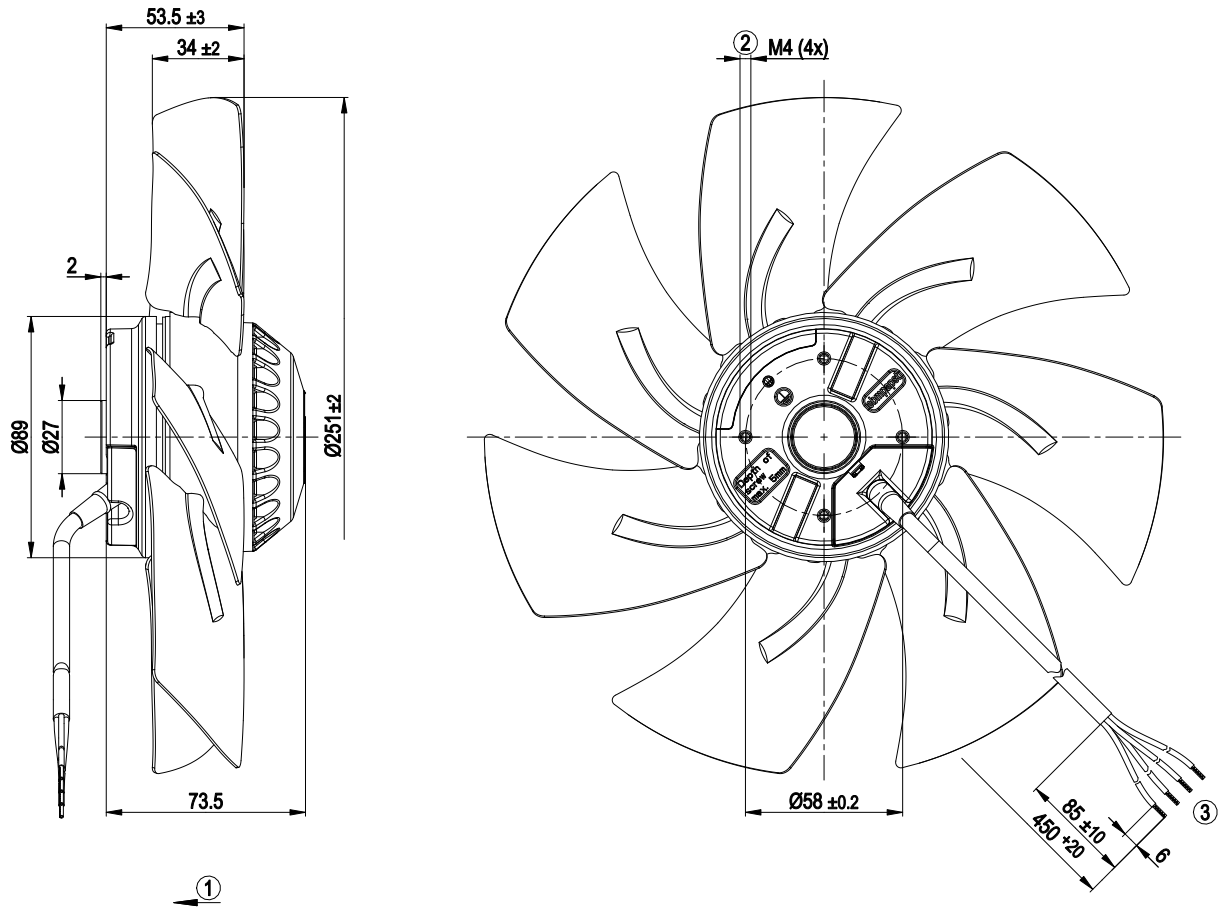

1	Airflow direction "V"
2	Max. clearance for screw 5 mm
3	Cable PVC AWG20
	4x splice



## Connection diagram

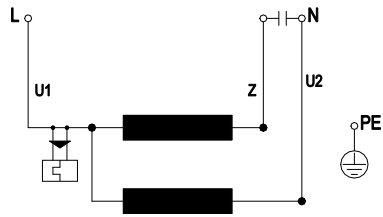

U1	blue	Z	brown	U2	black
PE	green/yellow				

## Curves: Air performance 50 Hz

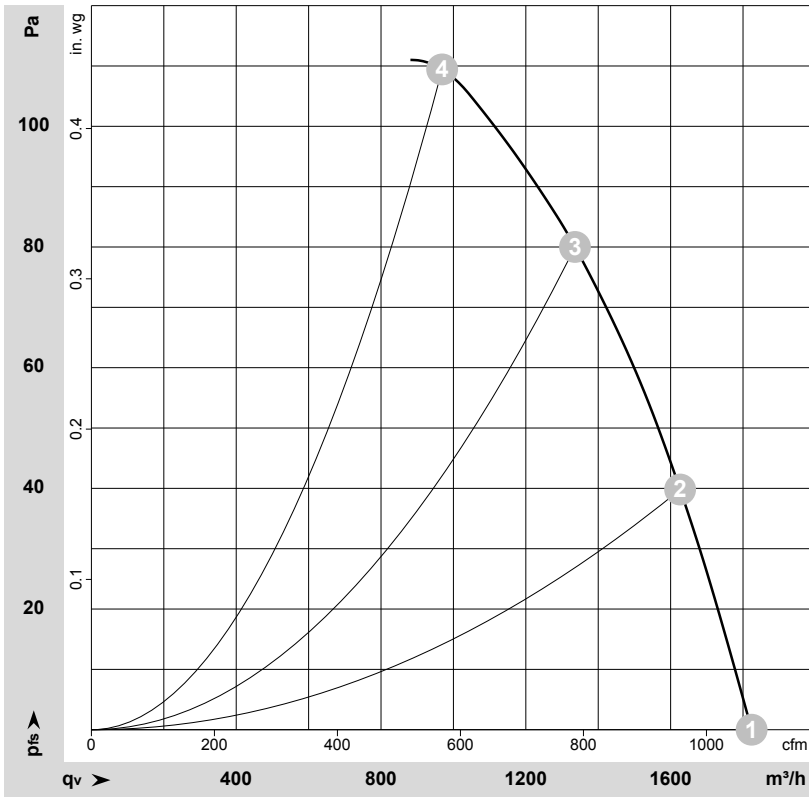

$\rho = 1.15 \text{ kg/m}^3 \pm 2 \%$

Measurement: LU-59608-1

Air performance measured according to ISO 5801 installation category A. For detailed information on the measurement setup, contact ebmpapst. Intake sound level: Sound power level according to ISO 13347 / sound pressure level measured at 1 m distance from fan axis. The values given are valid under the specified measuring conditions and may vary due to conditions of installation. For deviations from the standard configuration, the parameters have to be checked on the installed unit.

## Measured values

	Wired	U	f	n	P <sub>e</sub>	I	q <sub>v</sub>	p <sub>fs</sub>	q <sub>v</sub>	p <sub>fs</sub>
		V	Hz	min <sup>-1</sup>	W	A	m <sup>3</sup> /h	Pa	cfm	in. wg
1	1~	230	50	2450	115	0.51	1825	0	1075	0.00
2	1~	230	50	2415	121	0.52	1625	40	955	0.16
3	1~	230	50	2320	129	0.56	1335	80	785	0.32
4	1~	230	50	2265	134	0.58	970	110	570	0.44

Wired = Wiring · U = Voltage · f = Frequency · n = Speed (rpm) · P<sub>e</sub> = Power consumption · I = Current draw · q<sub>v</sub> = Air flow · p<sub>fs</sub> = Pressure increase



## Curves: Air performance 60 Hz

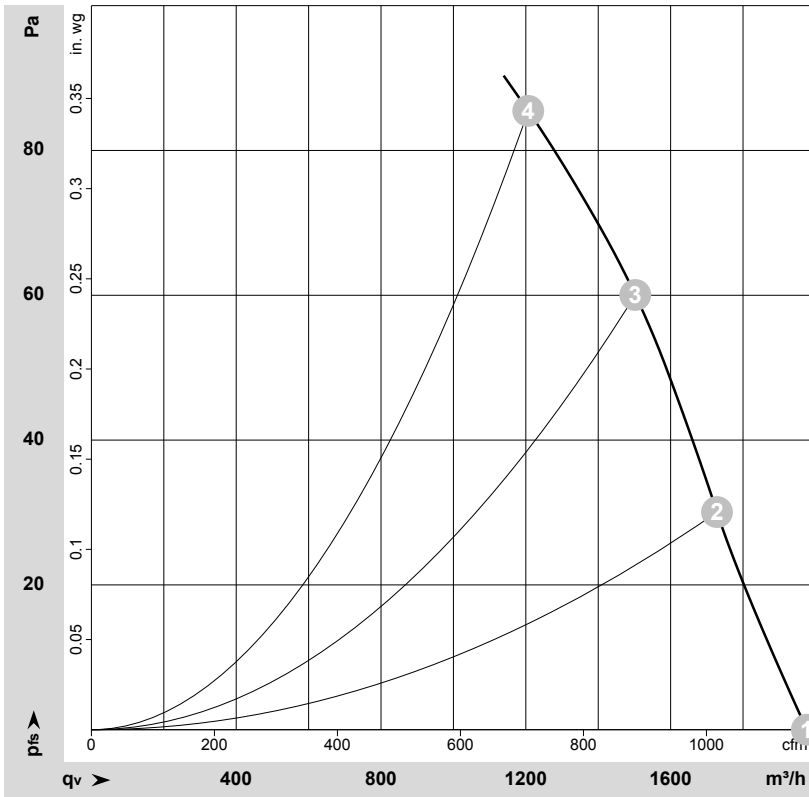

$\rho = 1.15 \text{ kg/m}^3 \pm 2 \%$

Measurement: LU-59609-1

Air performance measured according to ISO 5801 installation category A. For detailed information on the measurement setup, contact ebm-papst. Intake sound level: Sound power level according to ISO 13347 / sound pressure level measured at 1 m distance from fan axis. The values given are valid under the specified measuring conditions and may vary due to conditions of installation. For deviations from the standard configuration, the parameters have to be checked on the installed unit.

## Measured values

	Wired	U	f	n	P <sub>e</sub>	I	q <sub>v</sub>	P <sub>fs</sub>	q <sub>v</sub>	P <sub>fs</sub>
		V	Hz	min <sup>-1</sup>	W	A	m <sup>3</sup> /h	Pa	cfm	in. wg
1	1~	230	60	2600	150	0.66	1975	0	1165	0.00
2	1~	230	60	2520	156	0.68	1730	30	1015	0.12
3	1~	230	60	2405	160	0.70	1500	60	885	0.24
4	1~	230	60	2285	164	0.72	1205	85	710	0.34

Wired = Wiring · U = Voltage · f = Frequency · n = Speed (rpm) · P<sub>e</sub> = Power consumption · I = Current draw · q<sub>v</sub> = Air flow · P<sub>fs</sub> = Pressure increase