

PART # RG010.06

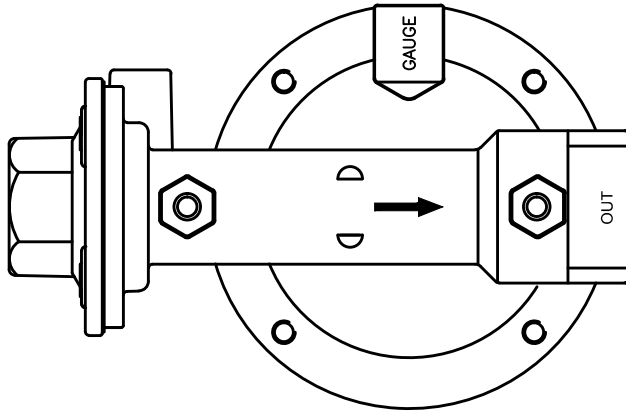

LABEL ON REGULATOR

Second Stage Compact LP Gas Regulator
 Model : RG010.06 | PRV : 80 mbar
 Capacity : 20kg/hr Propane
 Nominal Outlet pressure : 37 mbar Δ P2
 Inlet pressure : 0.7 to 4 bar
 Tested according to EN 16129

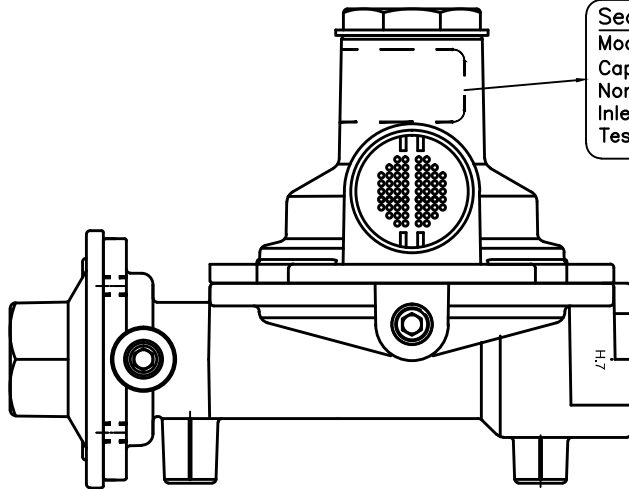

INT THREAD 3/4" BSPP

STICKER FOR PACKING BOX

Second stage Tank Regulator with PRV
 Model : RG010.06
 Type of gas : Propane
 Capacity : 20kg/hr max.
 Outlet pressure : 37 mbar
 Inlet pressure : 0.7 to 4 bar
 Inlet connection : 1/2" BSPP (F)
 Outlet connection : 3/4" BSPP (F)
 www.boldringroup.it



"MMYY" PERMANENT MARKING BY STAMPING / LASER

G.14
 PERMANENT MARKING BY STAMPING / LASER
 INT THREAD 1/2" BSPP

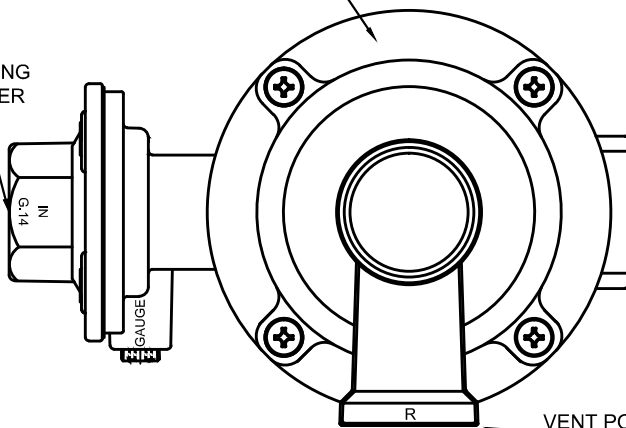

VENT POSITION 9 O' CLOCK

REGULATOR COLOUR : SILVER GREY

VENT POSITION 9 O' CLOCK

						DRN.BY	CHD.BY
NO.	ALTERATION	DATE	NO.	ALTERATION	DATE	DATE	
DIMENSIONS IN MM.					SCALE		
MATERIAL :					2 : 1		
					TITLE :		DRG. NO.
					Second stage regulator RG010.06		