



## TWHP - High performance Two-in-one buffer store for heat pumps Twin HP

Twin HP consists of two cylinders in a single body: the upper tank is a buffer store for primary water with instantaneous production of domestic hot water (DHW) through a high efficiency heat exchanger made of a corrugated stainless steel pipe. The lower tank is a buffer store for primary water for the heating system. It is available in two options:

buffer store + DHW production (TWOHP) and buffer store + DHW production and auxiliary heat exchanger (TW1HP). Twin HP represents a very cost effective and compact solution that allows space savings on domestic applications powered by modern hydronics heat pumps. Cylinders are also prepared to host a backup immersion heater (not supplied).

HEAT SOURCE



APPLICATION



TECHNICAL FEATURES	Primary water buffer vessel	<b>Material</b>	S 235 Jr Carbon steel
		<b>Internal protective treatment</b>	None
		<b>External protective treatment</b>	Anti rust protection + epoxy painting
		<b>Rating (P max. / T max.)</b>	3 bar / 95°C
	DHW Heat exchanger	<b>Material</b>	AISI 316L Stainless steel (1.4404)
		<b>Internal protective treatment</b>	Pickling and passivation
		<b>External protective treatment</b>	Pickling and passivation
		<b>Type</b>	Corrugated pipe
		<b>Rating (P max. / T max.)</b>	6 bar / 95°C
	Auxiliary heat exchanger	<b>Material</b>	AISI 316L Stainless steel (1.4404)
		<b>Internal protective treatment</b>	Pickling and passivation
		<b>External protective treatment</b>	Pickling and passivation
		<b>Type</b>	Corrugated pipe
		<b>Rating (P max. / T max.)</b>	6 bar / 95°C
		<b>Capacity</b>	300 - 400 L
		<b>Warranty</b>	5 years
		<b>Insulation</b>	Rigid polyurethane foam + PVC: Fire retardant class B3 (DIN 4102)
	General features	<b>In compliance with</b>	- Pressure Equipment Directive (PED) 2014/68/UE Art. 4 Para 3 - Italian MOH specifications (products suitable to contain potable water) - Energy related Products (Erp) Directive 2009/125/CE

ACCESSORIES (page 218)



Electronic control unit



Thermostat



Thermometer



1 1/2 electric immersion heater

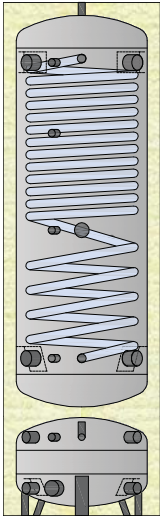

### TW0HP - Hard insulation with rigid polyurethane foam and PVC jacket

CODE	INSULATION THICK. (mm)	ErP CLASS	HEAT LOSS S (W)	UPPER BUFFER CAPACITY (L)	DHW HEAT EXCHANGER (m <sup>2</sup> ) / (L) *	LOWER BUFFER CAPACITY (L) *
TW0HP 00300 R	50	B	57,3	289,8	4,0 / 17,0	58,0
TW0HP 00400 R	50	B	69,8	404,9	5,0 / 20,6	85,0

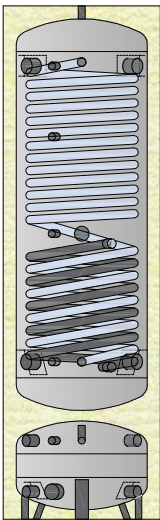

### TW1HP - Hard insulation with rigid polyurethane foam and PVC jacket

TW1HP 00300 R	50	B	57,3	289,8	4,0 / 17,0	1,2 / 4,4	58,0
TW1HP 00400 R	50	B	69,8	404,9	5,0 / 20,6	1,4 / 5,3	85,0

**TW\_HP - DHW heat exchanger pressure drops**

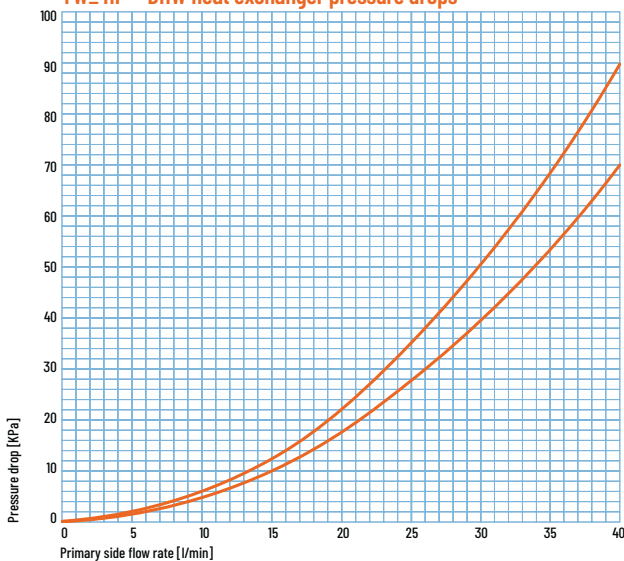

**TW1 HP - Auxiliary heat exchanger pressure drops**

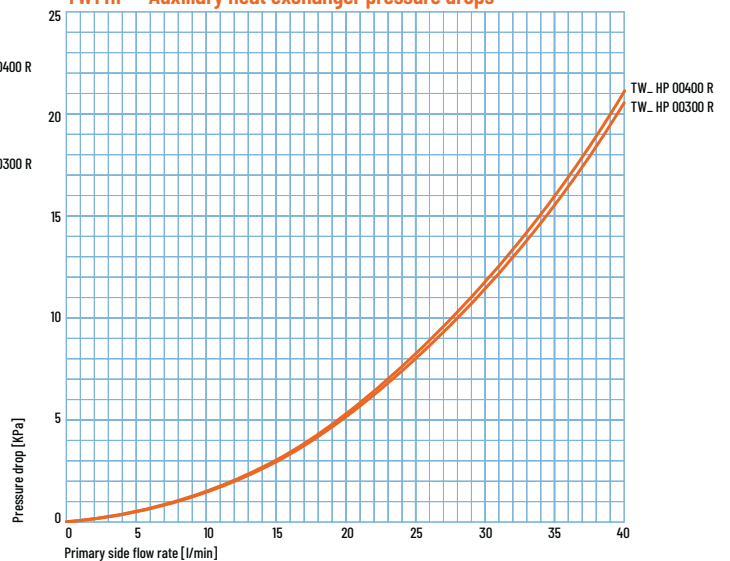

\* Volume occupied by the heat exchanger and its support structure

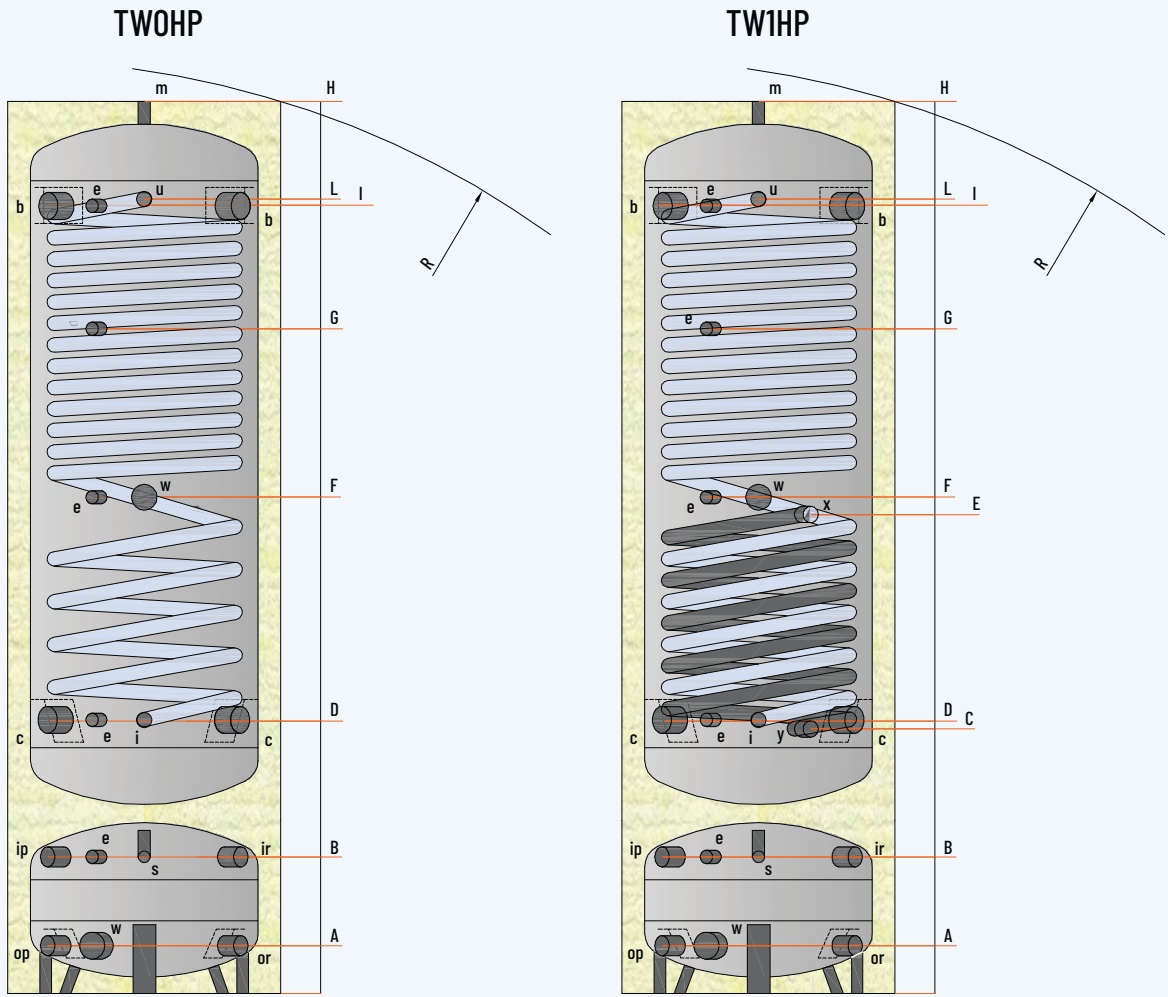

### LEGEND

- b** . Heat source flow
- c** . Heat source return
- e** . Thermometer - Sensor
- i** . Domestic cold water inlet
- m** . Buffer vent
- u** . Domestic hot water outlet
- w** . Opening for immersion heater
- x** . Solar system flow
- y** . Solar system return
- ip** . Heat pump flow to buffer vessel
- op** . Heat pump return from buffer
- ir** . Air conditioning system flow
- or** . Air conditioning system return
- s** . Buffer vent

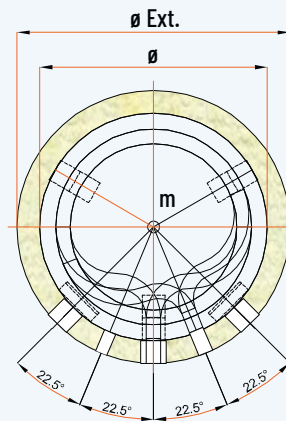

MODEL	DIMENSIONS (mm)		$\varnothing$ EXT *	R	DHW HEAT EXCHANGER (m <sup>2</sup> ) / (L)	AUXILIARY HEAT EXCHANGER (m <sup>2</sup> ) / (L)	BUFFER VOLUME (L)	WEIGHT (kg)
	$\varnothing$	H						
TW_HP 00300 R	500	1980	600	2090	4,0 / 13,7	1,2 / 4,1	58,0	127
TW_HP 00400 R	600	2020	700	2160	5,0 / 15,6	1,4 / 4,8	85,0	154

\* The insulation is not removable

MODEL	HEIGHTS (mm)									CONNECTIONS (GAS)						
	A	B	C	D	E	F	G	I	L	b c	x y	e	i u	m s	ip op or ir	w
TW_HP 00300 R	105	300	581	601	1052	1090	1460	1730	1746	1"½	¾"	½"	¾"	½"	1"	1"½
TW_HP 00400 R	125	310	620	640	1016	1054	1500	1760	1775	1"½	¾"	½"	¾"	½"	1"	1"½

Disclaimer: this layout is purely indicative. It does not replace consultant's design

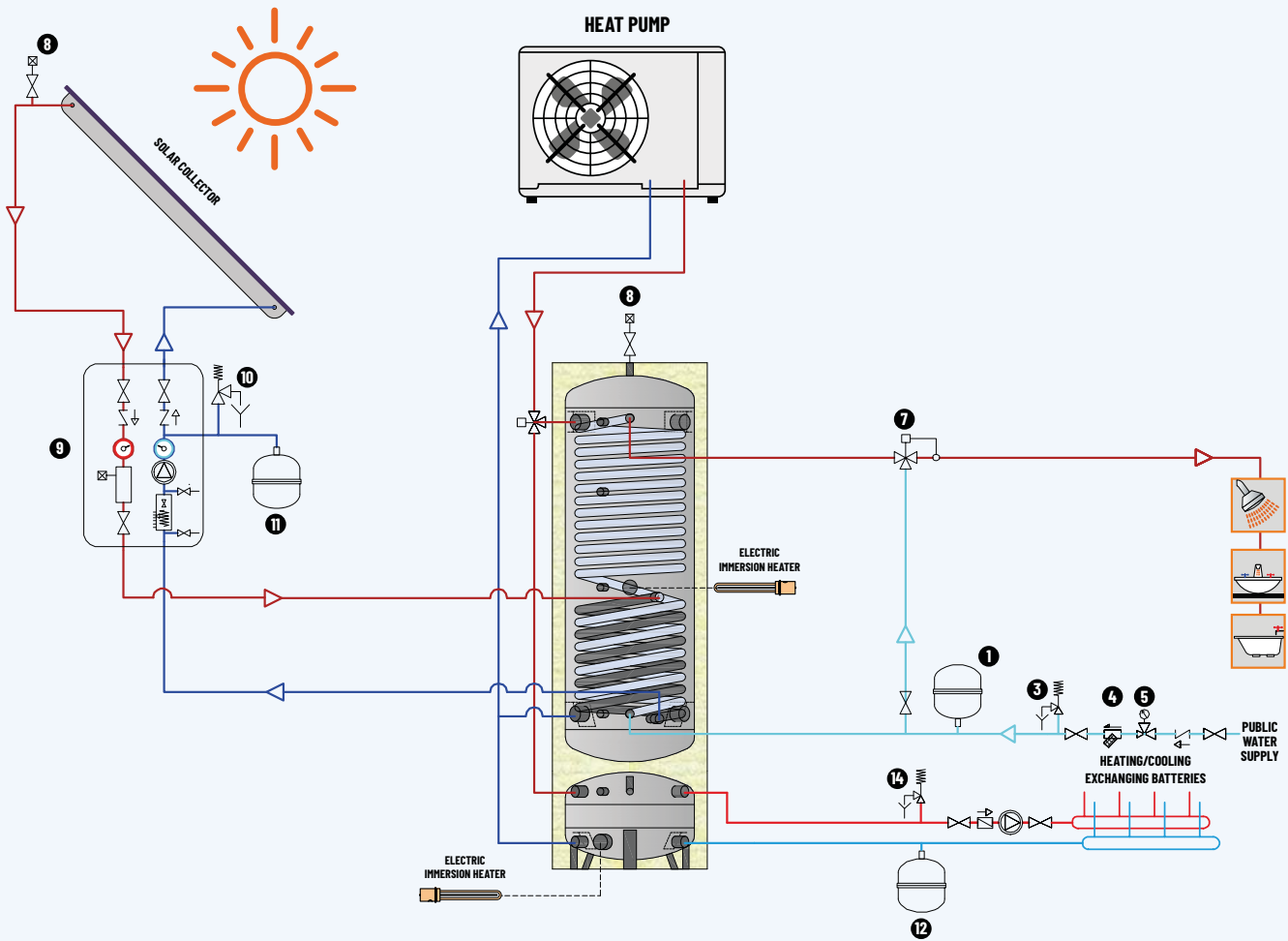
 COMBINED  
 THERMAL STORES

**LEGEND**

- |                                         |                               |                                      |
|-----------------------------------------|-------------------------------|--------------------------------------|
| 1 . Domestic water expansion vessel     | 7 . DHW 3-way valve           | 11 . Solar system expansion vessel   |
| 3 . Domestic water safety valve (6 bar) | 8 . Vent with valve           | 12 . Heating system expansion vessel |
| 4 . Strainer                            | 9 . Solar system control unit | 14 . Heating system safety valve     |
| 5 . Pressure reducing valve             | 10 . Solar system safety kit  |                                      |

**TW\_ HP Domestic Hot Water performance**

CODE	TW_ HP 00300 R	TW_ HP 00400 R
DHW Heat exchanger m <sup>2</sup> (L)	4,0 (13,7)	5,0 (17,0)
Power (kW)	36,0	45,0
DHW Continuous draw <sup>(1)</sup> (L/h)	884	1105
DHW <sup>(2)</sup> producible with a 10 L/min flow rate, with a totally heated buffer and a not running heat source		
Buffer at 55 °C (L)	82	112
Buffer at 65 °C (L)	185	252
Buffer at 70 °C (L)	269	367
DHW <sup>(2)</sup> producible with a 20 L/min flow rate, with a totally heated buffer and a not running heat source		
Buffer at 55 °C (L)	45	61
Buffer at 65 °C (L)	112	153
Buffer at 70 °C (L)	175	139
NL <sup>(3)</sup>	1	1,2

(1) Average buffer temp. 65 °C, DHW from 10 to 45° C

(2) from 10 to 45° C

(3) Buffer at 70 °C, DHW from 10 to 45° C

**TW1 HP auxiliary heat exchanger performance**

CODE	TW1 HP 00300 R	TW1 HP 00400 R
Heat exchanger m <sup>2</sup> (L)	1,2 (4,1)	1,3 (4,5)
Power (kW)		
$\Delta T^{(4)} = 10^\circ \text{C}$	6,3	6,8
$\Delta T^{(4)} = 15^\circ \text{C}$	9,5	10,2
$\Delta T^{(4)} = 20^\circ \text{C}$	12,6	13,6
$\Delta T^{(4)} = 25^\circ \text{C}$	15,8	17,0

 (4)  $\Delta T$ : difference between the average temperature of the heating fluid (inside the heat exchanger) and the average temperature of the heated fluid (internal to the buffer in the area affected by the coil).