

**DATA SHEET CONDENSING UNIT UCG 200U**

MTH CODE - DESCRIPTION	14902.5	UCG 200U	
REFRIGERANT	R452A		
APPLICATION	LBP		
POWER SUPPLY	220-240 / 1~ / 50		
EXPANSION	VALVE EXPANSION		
HP - LIQUID RECEIVER (Lt)	2	4.2	
FAN (no°) - DIAMETER (mm) - Watt	1	300	34
DIMENSIONS (PxLxH )	600	510	430
CONNECTION ( IN / OUT )	5/8" - 16	3/8" ods	

H=430  
P=600  
L=510

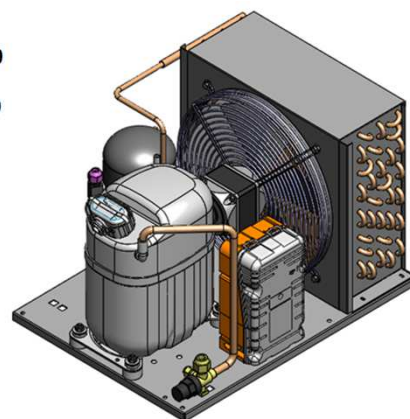

Nota: Foto rappresentativa

**COMPRESSOR**

COMPRESSOR TYPE			HERMETIC		
POWER SUPPLY			220-240 / 1~ / 50		
COMPRESSOR MANUFACTURER			TECUMSEH		
MTH CODE - DESCRIPTION			00153.2	FH2480Z-T	
CC <sub>3</sub>	W IN	A IN	53.2	1452	6.41
DATASHEET VENDOR					

**CONDENSING UNIT PERFORMANCES**

Code	Model	Compr.	Potenza sonora dB(A)	HP	-40 °C	-35 °C	-30 °C	-25 °C
14902.5	UCG 200U	FH2480Z-T	70	2	668 W	1.093 W	1.580 W	2.137 W

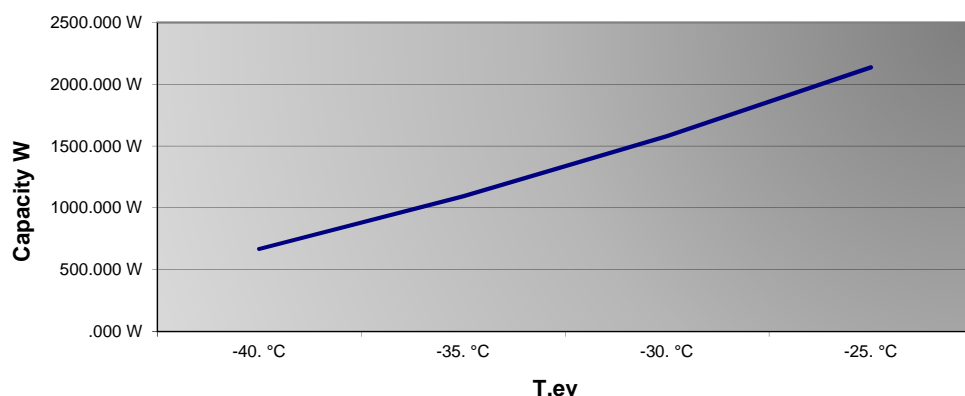

Test conditions T<sub>ev</sub> = -30°C

Condensing temperature +45°C, Ambient temperature +32°, Superheat 2K, Subcooling 8K (1 fan)

MTH S.r.l. has the right to make, anytime and without prior notice, updating and technical changes without the duty of informing third party.