

Compresseur / Compressor  
Code tension / Voltage code : TZ

# TAJ2464Z-TZ

Froid commercial négatif (BP)  
Low back pressure commercial application

400-440V / 50-60Hz - 3~

R404A



N° 124SU-TZ - ind a

Conditions Conditions	fréquence frequency	Prod frigorifique nominale / nominal refrigerating capacity			Puis. sonore Sound level
		Watts	Kcal/h	BTU/h	
EN12900*	50 Hz	820	705	2796	ISO 3745 / ISO 3743-1  63 dBA
EN12900*	60 Hz	900	774	3069	

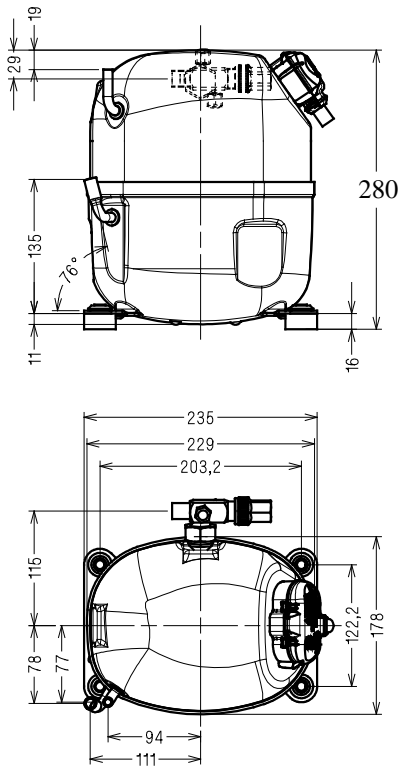

**Cylindrée / Displacement :** 34.5 cm<sup>3</sup>  
**Poids net / Net weight :** 21.2 Kg  
**Charge en huile / Oil charge :** 475 cm<sup>3</sup>  
**Type d'huile / Oil type :** P.O.E /  
**Détente / Expansion device :** Capillaire/Détendeur  
 Capillaire/Exp° valve  
**Refroidissement / Cooling :** Ventilé / Forced

**Résistance à 20° C / Windings resistances at 20° C**  
 Phases 1,2,3. / Phase Nr 1,2,3 : 11.8 Ohms

**Intensité / Current**  
 nom. / Rated current RLA : 2.2 / 2.1 A  
 max. / Max current : 3.8 / 4 A  
 dém. / Start current LRA : 15.9 / 16.3 A

**Ap. Electrique / Electrical equipment :** TRI

**Protecteur / Overload :** Interne / Internal

\* EN12900: T°cond.+40°C / T°évap.-35°C/ T°gas aspirés. +20°C /  
 Sous refroidissement. 0K  
 \* EN 12900 : Cond. T° +40°C / Evap. T° -35°C / Return gas T° +20°C /  
 Subcooling. 0K

Pour conduites Ø ext / For tubing O.D.

Aspiration Suction	Refoulement Discharge	Charge Process
15.9 (5/8")	9.5 (3/8")	6.35 (1/4")

Les caractéristiques données dans cette fiche technique peuvent évoluer sans avis préalable, avec les améliorations que 'Tecumseh' entend toujours apporter à sa production.  
 'Tecumseh', in a constant endeavour to improve its products reserves the right to change any information contained in this leaflet without prior warning.



Tecumseh

<b>TAJ2464Z-TZ</b>	<b>Tension TZ : 400V 3~ 50Hz / 440V 3~ 60 Hz</b>	<b>R404A</b>	<b>N°124SU-TZ</b>	<b>Ind a</b>
--------------------	--	--------------	-------------------	--------------

Les performances sont données dans les **conditions EN 12900** :  
Elles sont certifiées uniquement en 50 Hz

The performance data are in **EN 12900 conditions** :  
They are only certified in 50 Hz

Gaz aspirés : 20°C  
Sous refroidissement : 0°C

Return gas : 20°C  
Subcooling : 0°C

### 50 Hz R404A

4   T condensation	5   T évaporation (°C)		<b>-40</b>	<b>-35</b>	<b>-30</b>	<b>-25</b>	<b>-20</b>	<b>-15</b>	<b>-10</b>
<b>30</b>	1   P frigorigère (W)		752	1030	1365	1765	2234	2780	3408
	2   P absorbée (W)		650	770	892	1015	1141	1270	1405
	3   I absorbée (A)		1.57	1.69	1.83	1.99	2.16	2.35	2.56
<b>40</b>	1   P frigorigère (W)		578	<b>820</b>	1108	1449	1850	2317	2855
	2   P absorbée (W)		636	<b>778</b>	920	1066	1215	1369	1529
	3   I absorbée (A)		1.56	<b>1.71</b>	1.88	2.07	2.28	2.5	2.74
<b>50</b>	1   P frigorigère (W)			612	852	1135	1467	1854	2302
	2   P absorbée (W)			763	930	1100	1274	1455	1642
	3   I absorbée (A)			1.71	1.91	2.13	2.37	2.62	2.89
<b>60</b>	1   P frigorigère (W)				601	825	1088	1395	1752
	2   P absorbée (W)				918	1116	1318	1527	1744
	3   I absorbée (A)				1.91	2.16	2.43	2.72	3.02

### 60 Hz R404A

4   T condensation	5   T évaporation (°C)		<b>-40</b>	<b>-35</b>	<b>-30</b>	<b>-25</b>	<b>-20</b>	<b>-15</b>	<b>-10</b>
<b>30</b>	1   P frigorigère (W)		824	1131	1502	1944	2464	3068	3764
	2   P absorbée (W)		747	894	1037	1180	1330	1490	1667
	3   I absorbée (A)		1.46	1.62	1.79	1.99	2.2	2.43	2.68
<b>40</b>	1   P frigorigère (W)		636	<b>900</b>	1218	1596	2040	2558	3156
	2   P absorbée (W)		728	<b>901</b>	1071	1243	1422	1613	1822
	3   I absorbée (A)		1.45	<b>1.63</b>	1.84	2.07	2.31	2.58	2.86
<b>50</b>	1   P frigorigère (W)			678	942	1255	1623	2053	2553
	2   P absorbée (W)			870	1068	1269	1478	1700	1942
	3   I absorbée (A)			1.62	1.86	2.12	2.4	2.7	3.02
<b>60</b>	1   P frigorigère (W)				675	922	1213	1556	1956
	2   P absorbée (W)				1050	1281	1521	1776	2051
	3   I absorbée (A)				1.85	2.14	2.46	2.79	3.14

1 = refrigerating capacity      2 = watt input      3 = current      4 = condensing temperature      5 = evaporating temperature

Nota : Les caractéristiques données dans cette fiche technique peuvent évoluer sans avis préalable, avec les améliorations que "Tecumseh" entend toujours apporter à sa production.

Note : "Tecumseh", in a constant endeavour to improve its products reserves the right to change any information contained in this leaflet without prior warning.