







# ID 985 LX HG(/C /CK)

electronic controllers for “ventilated” refrigerating units

## USER INTERFACE

The user has a display and four keys for controlling status and programming of the instrument.

### KEYS AND MENUS

UP Key		Scrolls menu entries Increases values Activates manual def. function (see H31 parameter)
DOWN Key		Scrolls menu entries Decreases values Can be set by parameter (see H32 parameter)
fnc key		ESC function (exit) Can be set by parameter (see H33 parameter)
set key		Accesses the setpoint Accesses the menus Confirms the commands Displays the alarms (if active) Stores hours/minutes

At start-up the instrument performs a Lamp Test; for few seconds the display and the leds blink, in order to verify their integrity and correct operation. The instrument has two main menus: the “Machine Status” and “Programming” menu.

### ACCESSING AND USING MENUS

Resources are arranged in a menu, which can be accessed by pressing and quickly releasing the “set” key (“Machine Status” menu), or by holding down the “set” key for more than 5 seconds (“Programming” menu). To access the contents of each folder, indicated by the relevant label, just press the “set” key once. You can now scroll through the contents of each folder, modify it or use its functions. If you do not use the keyboard for over 15 seconds (time-out) or if you press the “fnc” key

once, the last value shown on the display is confirmed and you return to the previous screen mask.

### MACHINE STATUS MENU (See Machine Status Menu Diagram)

To access the “Machine Status” menu, press and quickly release the “set” key. If alarms are not present, the label “SEt” appears. By using the “UP” and “DOWN” keys you can scroll through the other folders in the menu:

- AL: alarm folder (if alarms present, except for faulty probe(s)/probe(s) error(s);
- SEt: Setpoint setting folder.
- rtc (models /C /CK): real time clock folder.
- Pb1: probe 1 value folder;
- Pb2: probe 2 value folder;
- Pb3: probe 3 value folder (if present);

### Set setting

Access the “Machine Status” menu by pressing and quickly releasing the “set” key. The label of the “Set” folder appears. To display the Setpoint value press the “set” key again. The value appears on the display. To change the Setpoint value, use the “UP” and “DOWN” keys within 15 seconds. If the parameter is LOC = y the Setpoint cannot be changed.

### Real Time Clock (models /C /CK)

By pressing the “set” key when the related “rtc” label appears, the label d00 (days) is displayed. Use the “UP” and “DOWN” keys to set days. If you do not use the keys for over 2 seconds, or if you press “ENTER” you switch to hours (h00) and minutes (’00) folders: use the “UP” and “DOWN” keys to set hours and minutes respectively. If you do not use the keyboard for over 15 seconds (time-out) or if you press the

“fnc” key once, the last value shown on the display is confirmed and you return to the previous screen mask.

**PLEASE NOTE: Always confirm with the “set” key to store the hours/minutes/days setting.**

**PLEASE NOTE 2: It is suggested to consider the first day d00 as SUNDAY Alarm on**

If an alarm condition exists, when accessing the “Machine Status” menu the “AL” folder label appears (see the “Diagnostics” section).

### Displaying probes

By pressing the “set” key when the appropriate label appears, the value of the probe associated to it is displayed.

### PROGRAMMING MENU

(See Programming Menu Diagram)

#### 1) Level 1 Parameters

To access the “Programming” menu, press the “set” key for more than 5 seconds. If specified, the level 1 access PASSWORD will be requested (see parameter “PA1”) and (if the password is correct) the label of the first folder will follow. If the password is wrong, the display will show the PA1 label again.

To scroll other folders, use the “UP” and “DOWN” keys; **the folders contain only the level 1 parameters.**

**NOTE: At this point level 2 parameters are NOT visible, even if they aren’t protected by password.**

#### 2) Level 2 Parameters

In the Programming Menu go into the “CnF” folder, scroll all the parameter until you reach the PA2 label. By pressing and releasing the “set” button you will enter to level 2 parameters and the label of the first folder in the programming menu will follow.





The level 2 parameters may be protected by a second password (see “PA2” parameter inside “diS” folder, not to be confused with PA2 label inside “CnF” folder.

If specified, level 2 parameters are hidden to user; accessing the “CnF” folder the level 2 access PASSWORD will be requested and (if the correct password is entered) the label of the first folder in the programming menu will follow.

**NOTE: At this point you will see only level 2 parameters.**

Level 1 parameters will NOT be visible; to reach them you shall exit the Programming Menu and re-entry the Programming Menu section (see step 1).

### LED

Position	Related Function	Status
ECO	Set/Reduced set	ON for Set-Point changing; blinking when the reduced set is on
	Compressor or relay 1 for delay.	ON for compressor on; blinking locked protection or activation
	Defrosting	ON when defrosting; blinking in case of manual or digital input activation
	Alarm	ON when the alarm is enabled; blinking when the alarm is silenced
	Fans	ON when fan is on
aux	aux	ON when the auxiliary output is on
	decimal point	ON when the instrument is in stand-by mode

To enter the folder, press “set”. The label of the first visible parameter appears. To scroll through the other parameters, use the “UP” and “DOWN” keys; to change the parameter, press and release “set”, then set the desired value using the “UP” and “DOWN” keys, and confirm with the “set” key. Move to the next parameter.

**PLEASE NOTE:** It is suggested to switch-off and switch-on again the instrument every-time it is changed the configuration of the parameters: this prevents malfunctioning on regulation and delay time occurring.

#### PASSWORD

The passwords “PA1” and “PA2” allow access respectively to level 1 and level 2 parameters. In the standard configuration passwords are not present. To enable and assign them (value 0) the desired value, access the “Programming” menu, within the folder with the “diS” label. If passwords are enabled, they will be requested:

- PA1 at the entrance of the “Programming” menu (see the “Programming Menu” section);
- PA2 within the folder with the “Cnf” label containing level 1 parameters.

#### ENABLING DEFROST CYCLE MANUALLY

To manually activate the defrosting cycle, press the “UP” key (if configured) for 5 seconds. If the conditions for defrosting are not present, (for example, the evaporator probe temperature is higher than the defrost end temperature), or if parameter OdO 0, the display will blink three (3) times, to indicate that the operation will not be performed.

#### COPY CARD

The Copy Card is an accessory connected to the TTL serial port which allows programming quickly the instrument parameters (upload and download parameter’s map). The operation is performed as follows:

##### Fr-Format (parameter level 2)

This command allows copy card formatting, an operation necessary in case of first use or to copy maps with different models. Warning: if the copy card has been programmed, using the “Fr” the data entered are erased. This operation cannot be cancelled.

##### UL-Upload

This operation loads the programming parameters from the instrument.

##### dL-Download

This operation downloads to the instrument the programming parameters.

##### NOTE:

- **UPLOAD: instrument --> Copy Card**
- **DOWNLOAD: Copy Card --> instrument.**

The operations are performed accessing the folder identified by the “FPr” label and selecting, according to the case, “UL”, “dL” or “Fr” commands; the operation is confirmed by pressing the “set” key. If the

operation is successful an “y” is displayed, on the contrary, if it fails a “n” will be displayed.

#### Download “from reset (instrument OFF)”

Connect the copy card with the instrument OFF (not under voltage).

When the instrument is switched on the programming parameters will be downloaded into the instrument; after the lamp-test the display will show for about 5 seconds:

- label dLY if copy operation successful
- label DLn if not

##### PLEASE NOTE:

- after the download operation the instrument will immediately work with the new parameters map setting.

#### TELEVIS SYSTEM

The TelevisSystem can be connected through TTL serial port (the TTL- RS 485 BUS ADAPTER 100 interface module must be used). To configure the instrument for this purpose you need to access to the folder identified by the “Add” label and to use the “dEA” and “FAA” parameters.

#### KEYBOARD LOCKING

The instrument includes a facility for disabling the keyboard, by programming the “Loc” parameter (see folder with “diS” label). In case of keyboard locking you can access to the “Programming” Menu by pressing the “set” key. The Setpoint can also be viewed.

## ADVANCED FUNCTIONS

#### LINK (only /CK models)

The Link function allows to connect up to 8 instruments (1 Master device and 7 slave and echo devices) to a network. The maximum distance between two subsequent devices must be 7 mt, while the maximum distance between first and last device of the network must be 50 mt approx.

**NOTE:** the serial connection between devices is power supplied.

##### Master

An instrument that manages the network by sending commands to Slaves. The Master is selected through the L00 parameter (the 0 value defines the Master)

##### Slave

Instrument(s) supplied with its (their) own controls which also performs commands issued by the Master.

##### Echo

Instrument(s) provided with a function to view just the values of the instrument which is associated to (thus it is not provided with its own I/O resources, but only acts as a repeater).

**NOTE:** only one Echo device can be connected to the instrument (Master or Slave; in case it is connected to a Slave module set L04=n).

#### Defrostings

The Link network allows to manage defrostings; the Master sends the command for defrosting, which can be performed synchronously (at the same time) or sequentially (defrost after defrost), without affecting the standard protections or delays of the instruments (see parameter L03). The Master can also activate the following functions: lights coming on and going off, alarm silencing, auxiliary Setpoint, aux relay, stand-by (on/off), and Night & Day control (see parameter L05). The Master can then synchronize Slave and Echo displays according to the Master or to a Slave display (for Echoes) (see parameter L04). NOTE: synchronous defrost is considered as regards the actual defrost, dripping and subsequent functions. The defrost LED of the Slaves blinks at the end of defrosting, when Slaves wait for the thermostat to be enabled by the Master. The functions of the instrument are associated by setting appropriately the correct parameters (see the parameter table of the folder with “Lin” label)

#### NIGHT & DAY CONTROL

The Night & Day control algorithm allows to set events and cycles at predefined times of the week. You can set an event start time and duration, as well as the functions and defrostings (daily, festive, or for “Everday”) to be enabled.

By pressing the “set” key when the related “nad” label appears, the label d0 (day 1.

**Suggestion: consider d00 = Sunday)** is displayed in the “Programming” menu. Use the “UP” and “DOWN” keys to set other days (**d1 (day 2 = Monday)...d6 (day 7 = Saturday)**) and Everyday).

By pressing “ENTER” the first parameter E00 is displayed; use the “UP” and “DOWN” keys to scroll through other parameters E01...03. If you do not use the keyboard for over 15 seconds (time-out), or if you press the “fnc” key once, the last value shown on the display is confirmed and you return to the previous screen mask.

The different functions are set through the appropriate parameters (see the parameter table of the folder with the “nad” label)

### HOT GAS ADJUSTMENT (HOT GAS)

The unit enables to select different types of defrosting by means of parameters **dt** and **defrost type (defrosting mode)**.

Parameter **dt** can assume the following values:

0 = Electric defrosting; the compressor is stopped

1 = Defrosting with cycle inversion (hot gas; this mode differs from the HOT GAS mode described in point 3); the compressor continues to run.

2 = Defrosting in "Free" mode (the compressor is disabled).

3 = Defrosting with hot gas (HOT GAS); even in this case the compressor continues to operate.

The defrosting with hot gas (HOT GAS) can be adjusted with the 4 digital outputs (relays) R1...R4 ... and divided into 4 or 9 phases according to whether R1=ON or OFF.

#### A. (R1=OFF) OPERATION WITH NO COOLING

The defrosting is enabled when valve R1 is off.

R2 is immediately enabled so that the defrosting can start.

This request is considered a manual one. Upon completion of the defrosting by probe (that takes into account parameter **ndt**) or by timeout (**par.dEt**), the unit starts dripping (**par.dt**) and subsequently returns to the ordinary operating mode. In this case, it is possible to enable R4 when a specific request is received by the thermoregulator and if R1 is above parameter **par. PdC**.

##### • Phase 1: defrosting request (defrost)

Checks the status of compressor before enabling the defrosting; pause before the enabling of defrosting; the interval of time changes according to the operating mode of the compressor.

This is the phase in which all **tcd** (Minimum Compressor Time On or OFF before defrost) and **Cod** (Compressor off (before) defrost Time for compressor OFF in proximity of defrost cycle) parameters are managed.

**NOTE: these parameters must be set to 0.**

**If the fans are off, they are restarted using parameter FdC.**

If the fans were on, they stay on for the time set in parameter **FdC** before the actual defrosting is restarted.

In this phase, fans must disable depending on the temperature (**par.FSt**).

##### • Phase 2: defrosting (defrost)

**NOTE:** it is possible to set the minimum duration of the defrosting cycle (see parameter **ndE**).

The fans move to ON taking into account the higher delays of **dt** and **Fdt**.

In this phase, fans must stop depending on the temperature.

**NOTE:** parameter **Fdt** shall start decreasing at the end of defrosting phase.

##### • Phase 3: by-pass

The bypass time can be set with parameter **dt**.

Parameter **bPS** enables to decide if the fans are on during **dt**.

If the fans are forced to ON, they must stop depending on temperature (paragraph **FSt**)

Parameters **Fdt** and **dt** are linked: the greater one always has priority.

##### • Phase 4: suction line solenoid ON

After the expiry of time **dt**, the suction line solenoid relay is ALWAYS enabled to (ON), even if there is no cooling request.

If a defrosting cycle is requested, the compressor ALWAYS starts after the expiry of the time set in parameter **PdC**.

**NOTE: during phases 1-4, fans are NOT controlled by parameter FCO.**

#### B. (R1=ON) OPERATION WITH COOLING

The defrosting request occurs when valve **R1 is on**. R1 is disabled while R4 is disabled after the interval of time set in **FdC** expires. R2 is enabled and the defrosting starts. The subsequent phases are similar to those described in Example 1.

• Phase 1: suction line solenoid ON

The suction solenoid is always set to ON regardless of whether cooling is requested.

• Phase 2-3: cooling request

• Phase 4: defrosting request (defrost)

see point A, phase 1, defrosting request.

• Phase 5: defrosting (defrost)

The suction solenoid disables after the delay set with **par. FdC**.

If the fans are on during the defrosting, these must stop depending on temperature;

• Phase 6: by-pass see point 3 by-pass

• Phase 7: suction solenoid ON

• Phase 8: cooling request

R1 wait for the **PdC** time to expire.

This time is loaded only after **dt**.

The fans move to ON taking into account the higher delays of **dt** and **Fdt**.

In this phase, fans must stop depending on the temperature.

**NOTE:** parameter **H45** (see) controls the setting of the probe (2 or 3) used to adjust the defrosting output. Default =0 (probe 2), customized setting=1 (probe3)

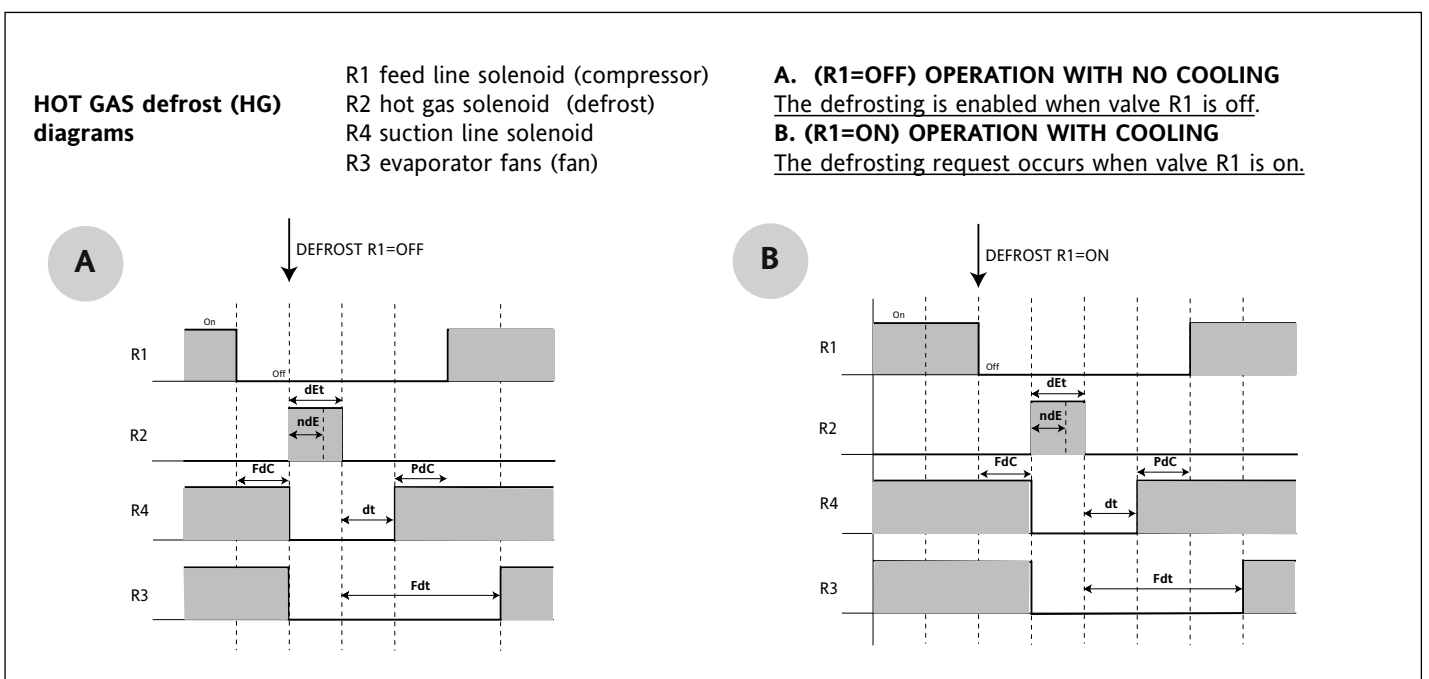

## DIAGNOSTICS

The alarm condition is always signaled by the buzzer (if present) and by the led of the alarm icon. The alarm signals from the faulty thermostat probe (probe 1), the faulty evaporator probe (probe 2), and the faulty display probe (probe 3) is viewed on the instrument display by E1, E2, and E3 respectively.

Probe faults table

DISPLAY	FAULT
E1	Faulty probe 1 (thermostat)
E2	probe 2 (1st evaporator)
E3	Faulty probe 3 (display)

If simultaneous, they will be showed on the display alternatively, every 2 seconds.

The error condition of the probe 1 (thermostat) causes the following:

- viewing E1 code on the display
- activating compressor as indicated by "Ont" and "Oft" parameters, if these are programmed for duty cycle or:

The error condition of the probe 2 (evap-

Ont	Oft	Compressor output
0	0	OFF
0	>0	OFF
>0	0	ON
>0	>0	D.C. (Duty Cycle)

orator) causes the following:

- viewing E2 code on the display
- end of defrost because of time-out.

The error condition of the probe 3 (display) causes the following:

- viewing E3 code on the display.

The other alarm signals do not show directly on the display, but can be viewed from the "Machine Status" menu within the "AL" folder.

The regulation of the maximum and minimum temperature alarm refers to the thermostat probe (probe 1) and/or display probe (probe 3). The temperature limits are defined by "HAL" (maximum alarm), "LAL" (minimum alarm) and PbA (alarm configuration on probe 1,3 or both) parameters.

### MAXIMUM AND MINIMUM TEMPERATURE ALARM

In case of alarm condition, if alarm exclusion times are not in progress (see, alarm exclusion parameters), the fixed alarm icon is turned on and the relay configured as an alarm is activated. This kind of alarm does not affect the regulation in progress. Alarms are considered as absolute (default) values or as values related to the Setpoint (the distance from the Setpoint itself) and based on the Att parameter. In this case (Att=1), the HAL parameter must be set to positive values and the LAL parameter to negative values.

This alarm condition can be viewed in the folder "AL" with the labels "AH1-AL1".

### ALARM WITH THRESHOLD (PROBE 3)

By setting the PbA=3 parameter an alarm is associated to probe 3. It refers to a specific threshold (defined by the SA3 parameter). Furthermore, an over-temperature or an under-temperature alarm is generated and the icon is turned on. This alarm condition can be viewed in the "AL" folder with the labels "AH3-AL3". The alarm is managed as a temperature alarm referred to probe 3: refer to standard delays and back swings

### DEFROST ALARM

If defrost ends because of a time-out (instead that because of a defrost end temperature detected by the defrosting probe), an alarm is generated and the icon is turned on consequently. This condition can be viewed in the "AL" folder with the label "Ad2". Automatic back swing occurs when the next defrost starts. By pressing any key during the alarm condition, the signal light disappears. In order to really erase the alarm you must wait the next defrost.

### EXTERNAL ALARM

The device includes the possibility to control an external alarm, from a digital input. If the digital input is active, the alarm control is activated, if programmed, and stays until the next time the digital input is deactivated. The alarm is signaled by turning on the fixed alarm icon, by activating the relay configured as alarm, and by deactivating compressor, defrost and fan controls (if specified by the "EAL" parameter). This alarm condition can be viewed in the "AL" folder with the label "EA". The relay can be silenced; even if alarm icon starts blinking, controls stay locked until the next time the digital input is deactivated.

### OPEN DOOR ALARM

In case of an open door, in response to delay defined by tdO parameter the Open Door alarm is signaled. The alarm is signaled by turning on the blinking alarm icon. This alarm condition can be viewed in the "AL" folder with the label "Opd".

### LINK (NETWORK) ALARM

In case of a network alarm (Master/slave/echo communication failure, the network NO LINK alarm is signaled. The alarm is signaled by turning on the blinking alarm icon. This alarm condition can be viewed in the "AL" folder with the label "E7".

#### PLEASE NOTE:

- The E7 error is signalled after 20 seconds in "no link" condition to avoid false alarms due to network disturbs;
- The E7 error is signalled also for address conflicting when:
  - a) the number of Slaves set on the Master is different from the effective number of Slaves on the network
  - b) 2 or more Slaves have the same address

Table of alarms

DISPLAY	ALARM
AH1*	High temperature alarm (referred to the thermostat probe or probe 1)
AL1*	Low temperature alarm (referred to thermostat probe or probe 1)
AH3	High temperature alarm (referred to probe 3)
AL3	Low temperature alarm (referred to probe 3)
Ad2	Defrost end due to time-out
EA	External alarm
Opd	Open door alarm
E7	Master-Slave communication failed (/CK models)
E10	Clock battery alarm (/C /CK models)

\*Alarms are in absolute value or related to Setpoint (considered as the distance from the Setpoint itself) depending on Att parameter.  
To silence the alarm, press any key.  
In this case the LED will blink

## MECHANICAL ASSEMBLY

The instrument is designed for panel mounting. Make a hole of 29x71 mm, insert the instrument and fix it using the brackets provided. Do not mount the instrument in humid and/or dirty places; it is suitable for use in ordinary polluted places. Ventilate the place in proximity to the instrument cooling slits.

## ELECTRICAL CONNECTIONS

Warning! Never work on electrical connections when the machine is switched on. The instrument is equipped with screw terminal boards for connection of electrical cables with a diameter of 2,5 mm<sup>2</sup> (one conductor only per terminal for power connections): for the capacity of the terminals, see the label on the instrument. The relay contacts are voltage free. Do not exceed the maximum current allowed; in case of higher loads, use an appropriate contactor. Make sure that power supply voltage meets the instrument voltage. Probes have no connection polarity and can be extended using a regular bipolar cable (note that the extension of the probes affects the EMC electromagnetic compatibility of the instrument: pay extreme attention to wiring). Probe cables, power supply cables and the TTL serial cables should be distant from power cables.

## CONDITIONS OF USE

### PERMITTED USE

For safety reasons the instrument must be installed and used according to the instruction provided and in particular, under normal conditions, parts bearing dangerous voltage levels must not be accessible. The device must be adequately protected from water and dust as per the application and must also only be accessible via the use of tools (with the exception of the frontlet). The device is ideally suited for use on household appliances and/or similar refrigeration equipment and has been tested with regard to the aspects concerning European reference standards on safety. It is classified as follows:

- according to its manufacture: as an automatic electronic control device to be incorporated by independent mounting;
- according to its automatic operating features: as a 1B-type operated control type;
- as a Class A device in relation to the category and structure of the software.

### UNPERMITTED USE

Any other use other than that permitted is de facto prohibited. It should be noted that the relay contacts provided are of a practical type and therefore subject to fault. Any protection devices required by product standards or dictated by common sense due to obvious safety reasons should be applied externally.

## RESPONSIBILITY AND RESIDUAL RISKS

Invensys Controls Italy S.r.L. shall not be liable for any damages deriving from:

- installation/use other than that prescribed and, in particular, that which does not comply with safety standards anticipated by regulations and/or those given herein;
- use on boards which do not guarantee adequate protection against electric shock, water or dust under the conditions of assembly applied;
- use on boards which allow access to dangerous parts without the use of tools;
- tampering with and/or alteration of the product;
- installation/use on boards that do not comply with the standards and regulations in force.

## TECHNICAL DATA

Front panel protection: IP65.  
 Container: plastic in PC+ABS UL94 V-0 resin casing, polycarbonate glass, thermo-plastic resin keys.  
 Size: front panel 74x32 mm, depth 60 mm.  
 Mounting: panel, with 71x29 mm (+0.2/0.1 mm) drilling template.  
 Usage temperature: -5...55 °C.  
 Storage temperature: -30...85 °C.  
 Usage environment humidity: 10...90 % RH (non-condensing).  
 Storage environment humidity: 10...90% RH (non-condensing).  
 View range: -50...110 (NTC); -55...140 (PTC) °C without decimal point (set by parameter), on a 3 and a half digits display and a plus sign.  
 Analogue inputs: three PTC or NTC inputs (set by parameter).  
 Digital inputs: 2 voltage-free digital inputs that can be set by parameter.  
 Serial: TTL for connecting a Televis system or a Copy Card.  
 Digital outputs: 4 outputs on relay:  
 first output (A) SPDT 8(3)A 250V~, second and third output (B-C) SPST 8(3)A 250V~, fourth output (D) SPST 5(2)A 250V~.  
 Link: Output for Link network  
**(only for /CK models)**  
 Measurement range: from -55 to 140 °C.  
 Accuracy: better of 0,5% than the end of scale +1 digit.  
 Resolution: 1 or 0.1 °C.  
 Consumption: 3 VA.  
 Power supply: 12 V~/= ±10% 50/60 Hz

**Warning: check the power supply indicated on the label of the instrument; for any information about the relay current carrying capacity and the power supply, contact the trade office.**

## AVAILABLE MODELS

Model	Features
ID 985LX HG	Base model with HOT GAS defrost without LINK and without CLOCK
ID 985LX HG/C	Model with HOT GAS defrost without LINK, with CLOCK
ID 985LX HG/CK	Model with HOT GAS defrost with LINK and with CLOCK

### Please Note:

C= CLOCK  
 K=LINK

**PLEASE NOTE: The technical data included in this document, related to measurement (range, accuracy, resolution, etc.) refer to the instrument itself, and not to its equipment such as, for example, sensors. This means, for example, that sensor(s) error(s) shall be added to the instrument's one.**

## DISCLAIMER

This manual and its contents remain the sole property of Invensys Controls Italy s.r.l., and shall not be reproduced or distributed without authorization. Although great care has been exercised in the preparation of this document, Invensys Controls Italy s.r.l., its employees or its vendors, cannot accept any liability whatsoever connected with its use. Invensys Controls Italy s.r.l. reserves the right to make any changes or improvements without prior notice.

### Duty Cycle Diagram

Ont, OFt parameters programmed for Duty Cycle

Ont	OFt	Output compressor
0	0	OFF
0	>0	OFF
>0	0	ON
>0	>0	dc

When the sensor detects an error condition:

- the code E1 is displayed
- the regulator is activated as indicated by the "Ont" and "OFt" parameters if programmed for the duty cycle or:

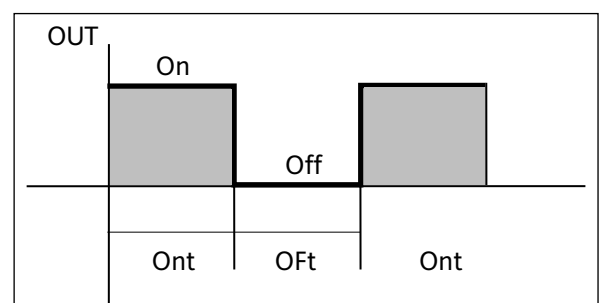

Tab. 1 Table of parameters

PAR.	DESCRIPTION	RANGE	DEFAULT	VALUE*	LEVEL**	U.M.
<b>COMPRESSOR REGULATOR (folder with "CP" label)</b>						
diF	diFferential. The compressor stops on reaching the Setpoint value (as indicated by the adjustment probe), and restarts at temperature value equal to the Setpoint plus the value of the differential. Note: the value 0 cannot be assumed.	0.1...30.0	2.0	2	1	°C/°F
HSE	Higer SEt. Maximum possible setpoint value.	LSE...302	50.0	18	1	°C/°F
LSE	Lower SEt. Minimum possible setpoint value.	-55.0...HSE	-50.0	-22	1	°C/°F
OSP	Offset SetPoint. Temperature value to be added algebraically to the setpoint in the case of reduced set enabled (Economy function). The reduced set can be enabled by a key configured on purpose.	-30.0...30.0	0	-10	2	°C/°F
Cit	Compressor min on time. Minimum compressor activation time before any possible disabling. If set at 0 it is not active	0...250	0	0	2	min
CAt	Compressor mAx on time. Maximum compressor activation time before any possible disabling. If set at 0 it is not active.	0...250	0	0	2	min
<b>COMPRESSOR PROTECTIONS (folder with "CP" label)</b>						
Ont	On time (compressor). Compressor activation time in the event of faulty probe. If set to "1" with OfT at "0" the compressor is always on, while at OfT >0 it functions always in duty cycle mode. <b>See Duty Cycle diagram</b>	0...250	0	10	1	min
OfT	OFF time (compressor). Compressor in disabled state time in the event of a faulty probe. If set to "1" with Ont at "0" the compressor is always off, while at Ont >0 it functions always in duty cycle mode. <b>See Duty Cycle diagram</b>	0...250	1	5	1	min
dOn	delay (at) On compressor. Delay time in activating the compressor relay after switch-on of instrument.	0...250	0	0	1	sec
dOF	delay (after power) OFF. Delay after switch off; the indicated time must elapse between switch-off of the compressor relay and the successive switch-on.	0...250	0	0	1	min
dbi	delay between power-on. Delay between switch-ons; the indicated time must elapse between two successive switch-ons of the compressor.	0...250	0	1	1	min
OdO (!)	delay Output (from power) On. Delay time in activating the outputs after switch-on of the instrument or after a power failure. 0= not active.	0...250	0	1	1	min
<b>DEFROSTING REGULATOR (folder with "dEF" label) (6)</b>						
dtY	defrost type. Type of defrost. 0 = electrical defrost; 1 = cycle reversing defrost (hot gas); 2 = Free mode defrost (compressor disabling). 3= HOT GAS defrost	0/1/2/3	0	0 (std model) 3 (HG model)	1	num
dtI	defrost interval time. Interval between the start of two successive defrosting operations. 0= the function is disabled (defrost is NEVER performed) U.M. Hours (default) /min/sec depending on dt1 parameter	0...250	6h	0	1	hours/min/sec (see dt1)
dt1	defrost time 1. Measure unit for time intervals between defrosting ("dtI" parameter). 0 = "dtI" parameter in hours; 1 = "dtI" parameter in minutes; 2 = "dtI" parameter in seconds.	0/1/2	0	0	2	num
dt2	defrost time 2. Measure unit for defrosting duration ("dEt" parameter). 0 = "dEt" parameter in hours; 1 = "dEt" parameter in minutes; 2 = "dEt" parameter in seconds.	0/1/2	1	1	2	num
dCt	defrost Counting type. Selection of count mode for the defrosting interval. 0 = compressor hour of operation (DIGIFROST® method); Defrosting active ONLY with the compressor on. NOTE: compressor time of operation is counted regardless the evaporator probe (counting is active if evaporator probe is absent or faulty). The value is ignored if RTC is enabled. 1 = Real Time - equipment hours of operation; defrost counting is always active when the machine is on and starts at each power-on. 2 = compressor stop. Every time the compressor stops a defrost cycle is performed according to the dtY 3= parameter with RTC. Defrostings at times set by d1...d87 parameters, F1...F8	0/1/2 /3 (0=df, digifrost 1=rt, real time, 2=SC, stop compressor 3=RTC)	1	3	1	num
"dd" (6)	dE1...dE8 daily defrost start time 1...8. Range 0...23, 24= off (default)	0...23/0...59	24	24	1	hours/min
"Fd" (6)	festive defrost start time 1...8. Range 0...23, 24= off (default) WARNING: dE1...dE8, F1...F8 parameters are visible only if dit=0, dCt=3 with clock option present. They are included in the dd and Fd folders	0...23/0...59	24	24	1	hours/min
dOH	defrost Offset Hour. Start-of-defrosting delay time from start up of instrument.	0...59	0	0	1	min
dEt	defrost Endurance time. Defrosting time-out; determines duration of defrosting. defrosting. U.M. minutes (default) /hours/sec depending on dt2 parameter	1...250	30min	25min	1	hours/min/sec (see dt2)
dSt	defrost Stop temperature. Defrosting end temperature (determined by the evaporator probe).	-50.0... 150	8.0	12	1	°C/°F
dPO	defrost (at) Power On. Determines if at start-up the instrument must enter defrosting (if the temperature measured by the evaporator allows this operation). y = yes, starts defrost at start-up; n = no, doesn't start defrost.	n/y	n	n	1	flag
ndE	Minimum defrosting time. This parameter enables to set a minimum defrosting time (except when external alarms occur (with EAL=1, see) or the machine turns off), even if the evaporator temperature is above dSt (see). If this parameter is set to 0, the function is inactive.	0...250	0	0	1	ore/min/sec
tcd	time compressor for defrost. Minimum time for compressor On or OFF before defrost. If >0 (positive value) the compressor will be ON for tcd minutes; If <0 (negative value) the compressor will be OFF for tcd minutes. If =0 parameter is disregarded If =0 is ignored	-31...31	0	0	2	min
Cod	Compressor off (before) defrost. Time for compressor OFF in proximity of the defrost cycle. If a defrost cycle is set within the programmed time for this parameter, the compressor is not started up. If =0 function is stopped.	0...60	0	0	2	min
<b>FANS REGULATOR (folder with "FAn" label)</b>						
Fpt	Fan Parameter type. "FSt" parameter mode. It can be expressed as temperature absolute value or as a value related to the Setpoint. 0 = absolute; 1 = relative.	0/1	0	0	2	flag
FSt	Fan Stop temperature. Fan lock temperature; a value, read by the evaporator probe higher than the set value causes the fans stop. The value is positive or negative and depending on Fpt parameter could represent the temperature in absolute value or relative to Setpoint.	-50.0...150.0	2.0	8	1	°C/°F

PAR.	DESCRIPTION	RANGE	DEFAULT	VALUE*	LEVEL**	U.M.
Fot	Fan on-start temperature. Fan start temperature; if the temperature read by the evaporator is lower than the value set for this parameter, the fans stay still. The value is positive or negative and depending on FPT parameter could represent the temperature in absolute value or relative to Setpoint.	-50.0..150.0	-50.0	-50	2	°C/°F
FAd	FAN differential. Fan activation intervention differential (see par. "FSt" and "Fot").	1.0...50.0	2.0	4	1	°C/°F
Fdt	Fan delay time. Delay time at fan activation after a defrosting cycle.	0...250	0	1	1	min
dt	drainage time. Dripping time.	0...250	0	2	1	min
dFd	defrost Fan disable. It allows to select or to not select the exclusion of the evaporator fans during defrosting. y = yes; n = no.	n/y	y	y	1	flag
FCO	Fan Compressor OFF. It allows to select or to not select fan lock when compressor OFF (switched off). y = fans active (with thermostat; in response to the value read by the defrost probe, see "FSt" parameter); n = fans off; dc = duty cycle (through "Fon" and "FoF" parameters).	n/y/dc	y	n	1	num
Fod	Fan open door open. Fans active when the door is open Allows to select the fans stop when door is open, and the fan re-start when door will be closed (if they we active). n=fans stop; y=fans unchanged	n/y	n	n	2	flag
FdC	Fan delay Compressor off. Fan switch off delay dime after compressor stop. In minutes. =0 function excluded	0.99	0	1	2	min
PdC	Compressor operation/Valve enables suction valve This parameter enables to set the delay with which the compressor is started when the suction solenoid valve is enabled (provided that the valve stays on for all the interval of time set with parameter PdC). If this parameter is set to 0, the function is inactive.	0...250	1	1	1	min
Fon	Fan on (in duty cycle). Time the fans are ON in a duty cycle. Use of fans in duty cycle mode; valid for FCO = dc and H42=1 (evaporator probe present)	0.99	0	0	1	min
FoF	Fan oFF (in duty cycle). Time the fans are OFF in a duty cycle. Use of fans in duty cycle mode; valid for FCO = dc and H42=1 (evaporator probe present)	0.99	0	0	1	min
bPS	Ventole attive durante il tempo dt (by-pass). Tramite questo parametro é possibile decidere se le ventole sono attive (n=no, y=yes (si)) durante la fase di by-pass (vedi algoritmo Hot Gas)	n/y	n	n	1	flag
<b>ALARMS (folder with "AL" label)</b>						
Att	Alarm type. Parameter "HAL" and "LAL" modes, as temperature absolute values or as differential compared to the Setpoint. 0 = absolute value; 1 = relative value.	0/1	0	1	2	flag
AFd	Alarm Fan differential. Alarm differential.	1.0...50.0	2.0	4	1	C/°F
HAL (5)	Higher ALarm. Maximum temperature alarm. Temperature value (with regard to Setpoint, or as an absolute value based on Att) which if exceeded in an upward direction triggers the activation of the alarm signal. <b>See Max/Min. Alarm Diagram;</b>	LAL...150.0	50.0	9	1	°C/°F
LAL (5)	Lower ALarm. Minimum temperature alarm. Temperature value (with regard to Setpoint, or as an absolute value based on Att) which if exceeded in a downward direction triggers the activation of the alarm signal. <b>See Max/Min. Alarm Diagram;</b>	-50.0...HAL	-50.0	-2	1	°C/°F
PAO (1) (8)	Power-on Alarm Override. Alarm exclusion time after instrument switch on, after a power failure.	0...10	0	1	1	hours
dAO	defrost Alarm Override. Alarm exclusion time after defrost.	0.999	0	60	1	min
OAO	Alarm signaling delay after digital input disabling (door open). Alarm is only for high-low temperature alarms.	0...10	0	0	1	hours
tdO	time out door Open. Time out after alarm signal following digital input disabling (door open)	0...250	0	2	2	min
tAO (8)	temperature Alarm Override. Temperature alarm signal delay dime.	0...250	0	30	2	flag
dAt	defrost Alarm time. Alarm signal for defrost end due to time-out. n = activates alarm; y = does not activate alarm.	n/y	n	y	1	min
EAL	External Alarm Lock. External alarm to lock loads.	n/y	n	n	2	flag
AOP	Alarm Output Polarity. Polarity of alarm output. 0 = alarm active and output disabled; 1 = alarm active and output enabled.	0/1	1	0	2	flag
PbA	Configuring temperature alarm on probe 1 and/or 3. 0 = alarm on probe 1 (thermostation); 1 = alarm on probe 3 (display) ; 2 = alarm on probes 1 and 3 (both thermostation and display); 3 = alarm on probes 1 and 3 (both thermostation and display) on external threshold;	0...3	0	0	2	min
SA3	Probe 3 alarm Set-Point (display)	-50.0...150.0	0	150	2	°C/°F
dA3	Probe 3 alarm differential (display)	-30.0...30.0	2.0	2	2	°C/°F
<b>LIGHTS AND DIGITAL INPUTS (folder with "Lit" label)</b>						
dSd	Enabling light relay by door switch. n = door open, the light does not turn on; y = door open, the light turns on (if it was off).	n/y	y	y	2	num
dLt	Light relay disabling (switch off) delay (cell light). The cell light will remain on for dLt minutes after closing the door if dSd parameter is set for this.	0...31	0	0	2	flag
OFL	Light switch always disables light relay; enable the switching off through light switch even if it is enable the delay after closing the door (set by dLt)	n/y	n	n	2	min
dOd	digital input switches off loads . On digital input command, programmed as door-switch, allows to stop all the loads when opening the door and re-starting then when the door will be closed.	n/y	n	n	2	flag
dAd	loads digital input enabling delay.	0...255	0	0	2	flag
<b>(ONLY FOR /CK MODELS) LINK REGULATOR (folder with "Lin" label)</b>						
L00	It allows to select the instrument as Master (0), Slave (from 1 to 7), Echo(0, in this case the Echo is a repititor of the Master also if connected to a Slave)	0...7	0	1	2	min
L01	Referred to the Master only. Number of Slaves in the network (from 0 to 7). For Slaves/Echoes leave the value =0	0...7	0	0	2	num
L02	Presence of local Echoes referred to the single Slave. 0 = local Echo not present; 1 = local Echo present sharing the Slave view at fixed intervals; if Master or Slave identifies that the device is active, and shares in the network, at fixed intervals it's local view. 2 = Echo shows the display of the Slave associated (Slave and associated Echo should have the same L00 address)	0/1/2	0	0	2	num
L03	Referred both to Master and Slave. Simultaneous/sequential defrosting. Master: n = simultaneous; y = sequential. Slave: n = ignore; y = accept.	n/y	n	n	2	num
L04	Referred to Slave only. n = The Slave shows local values; y = The Slave shows the display of the Master	n/y	y	n	2	flag

PAR.	DESCRIPTION	RANGE	DEFAULT	VALUE*	LEVEL**	U.M.
L05	Referred both to the Master and the Slave. Master: n = does not request to Slaves to activate remote functions; y = requests to Slaves to activate remote functions. Slave: n = ignores remote functions activation; y = accepts remote functions activation.	n/y	n	n	2	flag
L06	Locks resources (compressors, fans, etc) at the end of defrosting. n=no; y=yes <b>PLEASE NOTE:</b> related to ddd parameter which as the priority on this parameter (see) <b>(ONLY FOR /C /JCK MODELS) NIGHT/DAY REGULATOR (folder with "nad" label)</b>	n/y	y	n	2	flag
E00	Functions disabled during events: 0 = management disabled; 1 = reduced set; 2 = reduced set+light; 3 = reduced set+light+aux. 4= instrument off	0..4	0	0	2	num
E01	Event start hours/minutes. Sets the event start time. Starting from this time the "night" mode will be enabled. The length is determined by E02 parameter	0...23/0...59	0	0	2	hours/min
E02	Event duration. Set the event length (type of event, see E00)	0/1	0	0	2	flag
E03	Enabling daily or festive defrosting lock. (0= "workdays" defrost sequence defined by d0...d8; 1= "holiday/sunday" defrost sequence defined by F0...F8) <b>PLEASE NOTE: doesn't affect on defrosting at intervals like Every Day event (same defrost schedule for working days/holidays)</b> <b>COMMUNICATION (folder with "Add" label)</b>	0...99	0	0	2	hours
dEA (!)	dEvice Address. Device address: indicates the appliance address to the management protocol. dEvice Address.	0..14	0	0	1	num
FAA (!)	Fa mily Address: indicates the appliance family to the management protocol. <b>DISPLAY (folder with "dis" label)</b>	0..14	0	0	1	num
LOC	(keyboard) LOCK. Keyboard locking. It is still possible to enter parameter programming and modify them, including the status of this parameter, in order to allow keyboard unlocking. y = yes; n = no.	n/y	n	n	1	flag
PA1	PA ssword 1. When enabled (value different from 0) it represent the access key for level 1 parameters.	0..250	0	0	1	num
PA2***	PA ssword 2. When enabled (value different from 0) it represents the access key for level 2 parameters.	0..255	0	0	2	num
ndt	number display type. View with decimal point. y = yes; n = no.	n/y	n	n	1	flag
CA1	CA libration 1. Calibration 1. Positive or negative temperature value added to the value read by probe 1, based on "CA"parameter settings.	-12.0...12.0	0	0	1	°C/°F
CA2	CA libration 2. Calibration 2. Positive or negative temperature value added to the value read by probe 2, based on "CA"parameter settings.	-12.0...12.0	0	0	1	°C/°F
CA3	CA libration 3. Calibration 2. Positive or negative temperature value added to the value read by probe 3, based on "CA"parameter settings.	-12.0...12.0	0	0	1	°C/°F
CA	CA libration intervention. Intervention on view offset, thermostat offset or both. 0 = modifies the temperature displayed only; 1 = adds to the temperature used by regulators, not to the temperature displayed, which stays unchanged; 2 = adds to the temperature displayed that is also used by regulators.	0/1/2	2	2	2	num
ldL	Low display Label. Minimum value the instrument is able to display.	-55.0...302	-55.0	-50	2	°C/°F
HdL	High display Label. Maximum value the instrument is able to display.	-55.0...302	140.0	140	2	°C/°F
ddl	defrost display Lock. Viewing mode during defrosting. 0 = shows the temperature read by the thermostat probe; 1 = locks the reading on the temperature value read by thermostat probe when defrosting starts, and until the next time the Setpoint value is reached; 2 = displays the label "deF" during defrosting, and until the next time the Setpoint value is reached.	0/1/2	1	1	1	num
Ldd	Lock defrost disable. Time-out value for delock display (DEF label) if reaching the setpoint is too long during defrosting, or if the Link (Master-Slave) communication fails (E7 error)	0..255	0	60	1	min
dro	display read-out. Select °C or °F for displaying the temperature read by the probe. 0 = °C, 1 = °F. <b>PLEASE NOTE: the switch between °C and °F DO NOT modify setpoint, differential, etc. (for example set=10°C become 10°F).</b>	0/1	0	0	1	flag
ddd	Selection of the value type to be shown on the display. 0 = Setpoint; 1 = probe 1(thermostat); 2 = probe 2(evaporator); 3 = probe 3 (display). <b>CONFIGURATION (folder with "CnF" label)</b>	0/1/2/3	1	1	2	num
H00 (1)	(!) Probe type selection, PTC or NTC. 0 = PTC; 1 = NTC.	0/1	1	1	1	flag
H02	Time to enable keys, if these are configured for a specific function. For ESC, UP and DOWN keys configured for specific function (defrost, aux, etc) it set the elapsed time for the manual activation of the related function. aux function has a fixed time of 1 second	0..15	5	5	2	sec
H06	key/input aux/door switch light active when instrument is off (but under tension)	n/y	y	y	2	flag
H08	Stand-by operating mode. 0=display switch off; 1= display on and loads stopped; 21= display off and loads stopped;	0/1/2	2	2	2	num
H11 (7)	Configuring digital inputs/polarity. 0= disabled; 1 = defrosting; 2 = reduced set; 3 = auxiliary; 4 = door switch; 5 = external alarm. *6 = disable store HACCP alarms (*only in HACCP models) 7 = stand-by (ON-OFF) 8 = maintenance requested	-8...8	0	2	2	num
H12 (7)	Configuring digital inputs/polarity. The same as H11. 0 = disabled; (7) WARNING! positive or negative values change polarity	-8...8	0	0	2	num



PAR.	DESCRIPTION	RANGE	DEFAULT	VALUE**	LIVELLO**	U.M.
H21 (!)	Digital output 2 configurability. (B) 0 = disabled; 1 = compressor; (default) 2 = defrosting; 3 = fans; 4 = alarm; 5 = auxiliary. 6 = stand-by 7 = light 8 = maintenance requested 9 = solenoid	0..9	1	1	2	num
H22 (!)	Digital output 1 configurability. (A) The same as H21. (2= defrosting; default)	0..9	2	2	2	num
H23 (!)	Digital output 3 configurability. (C) The same as H21. (3= fans; default)	0..9	3	3	2	num
H24 (!)	Digital output 4 configurability. (D) The same as H21. (4= alarm; default)	0..9	4	9	2	num
H25 (!)	<b>PARAMETER VISIBLE IN MODELS WITH BUZZER.</b> Configurability buzzer. (if present) 0 = disabled; 8= enabled (default); 1-7= not used	0..9	8	8	2	num
H31 (!)	Configurability UP key. 0 = disabled; 1 = defrosting; 2 = auxiliary; 3 = reduced set (economy). *4 = reset HACCP alarms (*only in HACCP models) *5 = disable HACCP alarms (*only in HACCP models) 6 = light 7 = stand-by 8 = maintenance requested	0..8	0	1	2	num
H32 (!)	Configurability DOWN key. Same as H31. (0= disabled; default)	0..8	0	0	2	num
H33 (!)	Configurability ESC key. Same as H31. (0= disabled; default)	0..8	0	0	2	num
H41	Control probe presence. n= not present; y= present.	n/y	y	y	2	flag
H42	Evaporator probe presence. n= not present; y= present.	n/y	y	y	2	flag
H43	Display probe presence. n= not present; y= present.	n/y	n	y	2	flag
H45	Configurability Probe (analogue input) to set the end of defrost 0 = end of defrost based on value read by probe 2 1 = end of defrost based on value read by probe 3	0/1	0	1	2	flag
reL	release firmware. Device version: read only parameter.	/	/	/	2	/
tAb	tAble of parameters. Reserved: read only parameter. <b>COPY CARD (folder with "Fpr" label)</b>	/	/	/	1	/
<b>label PA2</b> <b>Inside CnF folder it is possible to reach all level 2 parameters from label PA2 by pressing the "set" button</b> <b>SEE 2) level 2 Parameters paragraph</b>						
	Up load. Programming parameter transfer from instrument to Copy Card.	/	/	/	2	/
UL	Down load. Programming parameter transfer from Copy Card to instrument.	/	/	/	2	/
dL	Format. Erasing all parameters in the Copy Card.	/	/	/	2	/
Fr	<b>PLEASE NOTE: using "Fr" parameter (Copy Card formatting) the data within the Copy Card will be lost permanently. The operation cannot be cancelled.</b>					
				<b>* CUSTOM SETTINGS</b>		

- (1) For the default value NTC/PTC input, see the label on the instrument  
(2) Positive values: active input when the contact is closed; negative values: 1= Active when contact is open  
(3) This parameter is visible in versions with optional buzzer.  
(5) If alarm are relative, the HAL parameter must be set to positive values and the LAL parameter to negative values  
(6) Within the deF folder two folders: "dd" (daily defrost) and "Fd" (Festive Defrost); the first folder includes dE1...dE8 parameters (working day defrost start); the second folder, instead includes F1...F8 parameters (Festive defrost). The two folders are visible only if dit =3 and RTC is present.  
**PLEASE NOTE: DO NOT CONFUSE d0...d6 (days in nad folder) with d01...d08 (daily/working days start time defrost)**  
(7) WARNING! positive or negative values change polarity  
(8) Referred exclusively to high and low temperature alarms

\* VALUE column: **CUSTOM SETTINGS FOR HOT GAS**

\*\* LEVEL column: indicates the level of visibility for parameter that can be accessed by a PASSWORD (see the related paragraph)

\*\*\*\* PA2 is visible (it will be requested, if specified) at level 1 in **CnF folder** and can be set (it can be modified) at level 2 in **dis folder**

**(!) WARNING!**

- If one or more of these parameters highlighted with (!) are modified, the controller must be switched off and switched on again to ensure correct operation.
- It is strongly recommended, anyway to switch off and switch on again the controller anytime parameters have been changed to prevent malfunctioning on configuration and/or ongoing timings
- folder with "nad" label NIGHT/DAY REGULATOR: ONLY FOR /C /CK MODELS
- folder with "Lin" label LINK REGULATOR: ONLY FOR /CK MODELS

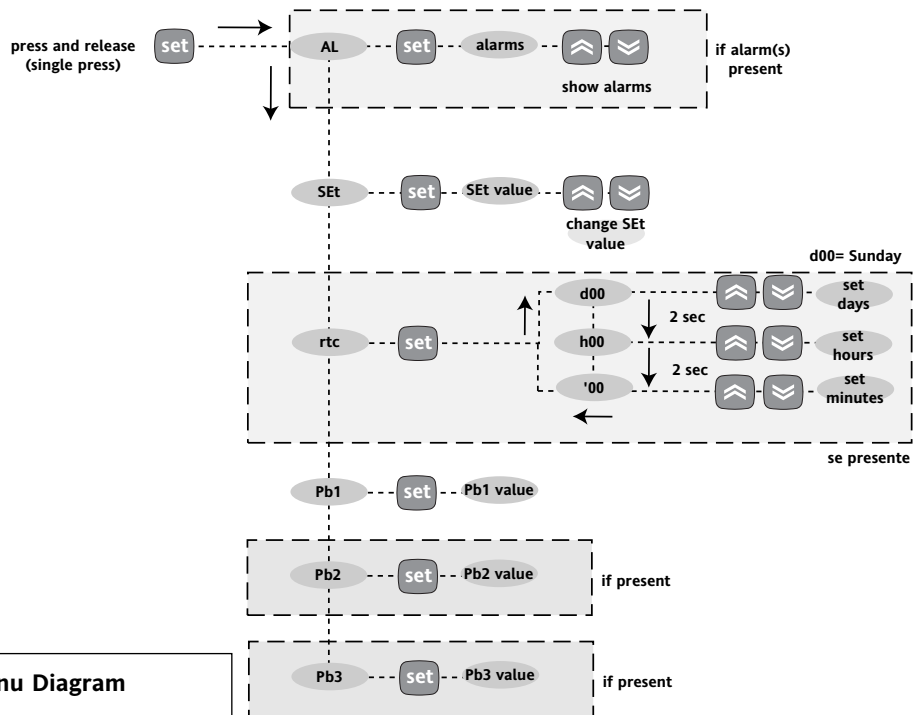

Machine Status Menu Diagram

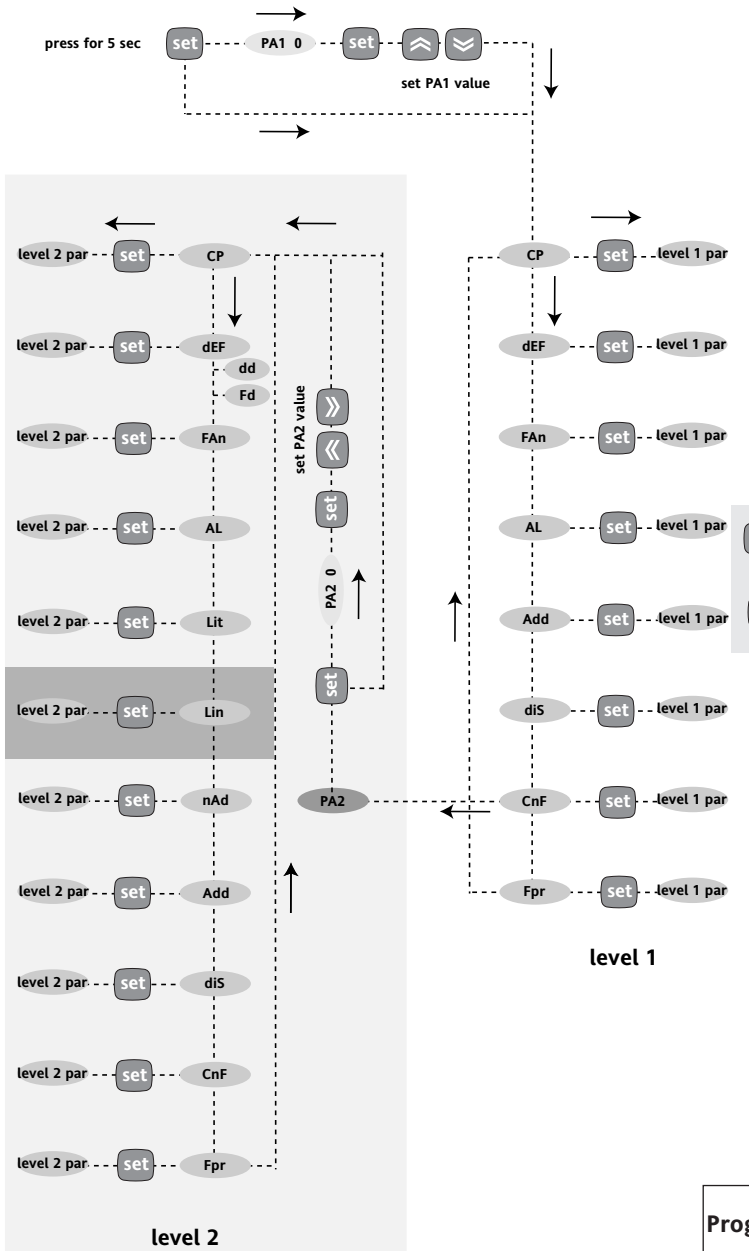

**PARAMETERS**

level 1 folders	level 2 folders
CP	CP
dEF (+dd+Fd)	dEF
FAn	FAn
AL	AL
Lit	-
Lin	-
nad	-
Add	Add
diS	diS
CnF	CnF
FPr	FPr

Programming Menu Diagram

## Max/Min. Alarms Diagram (Maximum and Minimum Temperature Alarms)

The maximum alarm will become when the probe temperature will be:

- (1) higher or equal to HAL if Att=Abs(olute)
- (2) higher or equal set + HAL if Att=rEL(ative)

- if Att=Abs(olute) HAL should be with sign;
- if Att=rEL(ative) HAL should be only positive

The minimum alarm will become when the probe temperature will be:

- (1) lower or equal to LAL if Att=Ab(solute)
- (2) lower or equal to set - LAL if Att=rEL(ative)

- if Att=Ab(solute) LAL should be with sign;
- if Att=rEL(ative) LAL should be only positive

The maximum alarm will ends when the probe temperature will be:

- (1) lower or equal to HAL - AFd if Att=Abs(olute)
- (2) lower or equal to set + HAL - AFd if Att=rEL(ative)

The minimum alarm will ends when the probe temperature will be:

- (1) higher or equal to LAL + AFd if Att=Abs(olute)
  - (2) higher or equal to set + LAL + AFd if Att=rEL(ative)
- \* (set - |LAL| + AFd)

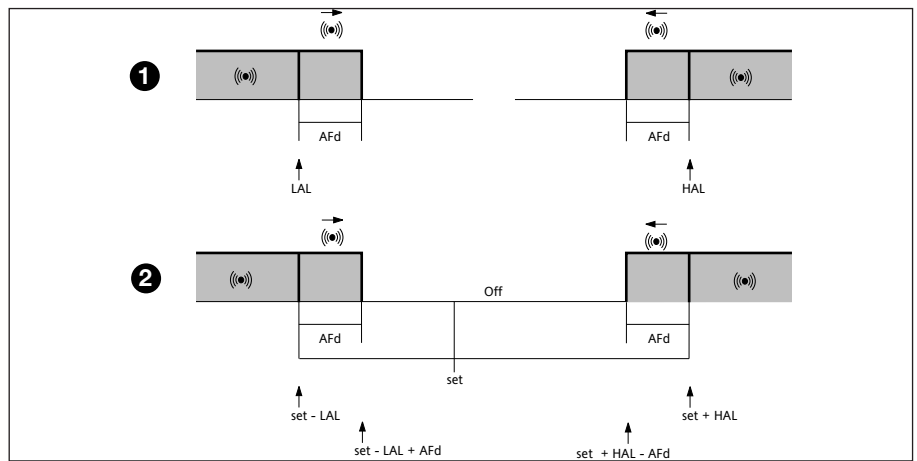

**\*PLEASE NOTE : if Att=rEL(ative) LAL should be only negative: so  $set + LAL < set$  because  $set + (- |LAL|) = set - |LAL|$**

### Wiring diagram

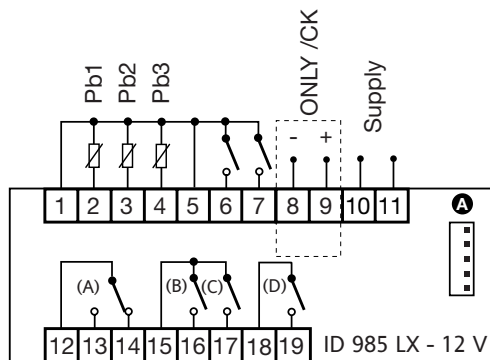

### TERMINALS

#### STANDARD CONFIGURATION

1 - 2	Probe 1 (thermostat) input
1 - 3	Probe 2 (evaporator) input
1 - 4	Probe 3 (display) input
5 - 6	Digital input 2
5 - 7	Digital input 1
8 - 9	Link (powered; 8= -, 9= +) <b>ONLY FOR /CK MODELS</b>
10 - 11	Power supply
12 - 13	N.O. Defrost relay (A)
12 - 14	N.C. Defrost relay (A) by-pass contact
15 - 16	N.O. Compressor relay. (B)
15 - 17	N.O. Fan relay (C)
18 - 19	N.O. Alarm relay (D)
A	TTL input for Copy Card and connection to TelevisSystem

#### HOT GAS I/O CONFIGURATION

*1 - 4	Probe 3 (display) input
5 - 6	Digital input 2
5 - 7	Digital input 1
8 - 9	Link (powered; 8= -, 9= +) <b>ONLY FOR /CK MODELS</b>
10 - 11	Power supply
**12 - 13	N.O. output hot gas solenoid (A) see par. H22=2
**12 - 14	N.C. by-pass contact
**15 - 16	N.O. output feed line solenoid see par. H21=1
**15 - 17	N.O. output fans evaporator see par. H23=3
**18 - 19	N.O. output suction line solenoid; see par. H24=9
A	TTL input for Copy Card and connection to TelevisSystem

**\*default on HOT GAS models**

**\*\*PLEASE NOTE CUSTOM SETTINGS FOR HOT GAS APPLICATIONS**

**Invensys Controls Italy s.r.l**

via dell'Industria, 15 Zona Industriale Paludi  
32010 Pieve d'Alpago (BL) ITALY  
Telephone +39 0437 986111  
Facsimile +39 0437 989066  
Internet <http://www.climate-eu.invensys.com>

9/2003 eng  
cod. 9IS53034