

Input data

Refrigerant	R404A	
Reference temperature	Dew point temperature	
Calculation mode	Refrigeration / Air Cond.	
Operating mode	Subcritical	
Power supply	400/3/50	
Condensing temperature	°C	45
Condensing pressure	bar	20,47
Liquid subcooling	K	0
Liquid temperature	°C	44,67
Evaporating temperature	°C	-25
Evaporating pressure	bar	2,5
Suction gas superheating	K	10
Useful fraction of superheating	%	100

Additional cooling required

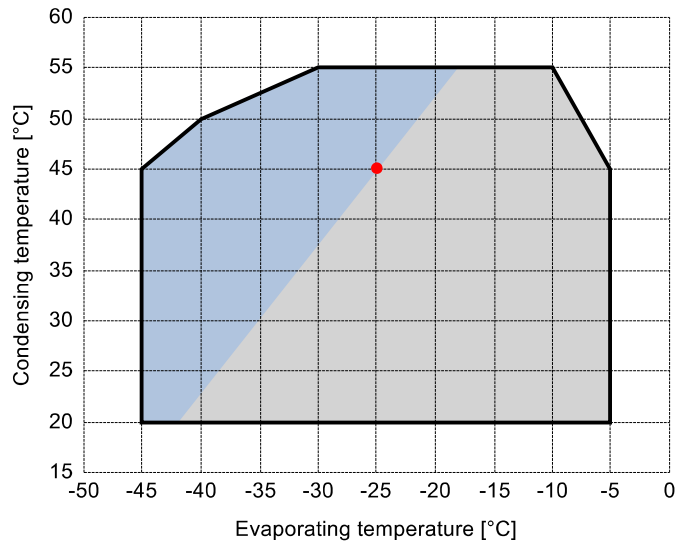

Output data

Compressor :	V15-71Y	
Number of compressors :	FSx1	
Refrigerating capacity	kW	16,314
Refrigerating capacity [*ref]	kW	18,573
Evaporator capacity	kW	16,314
Power input	W	12046
Condenser capacity, theor.	kW	28,361
Current	A	24,27
COP/EER	W/W	1,35
Mass flow	kg/h	635
Operating frequency	Hz	50
Connection	-	DOL-STAR
Operating mode	-	100%
Discharge temperature	°C	81,33
Ratio (%)	%	100,0%
Note	-	
Oil flow	l/min	-
Heat Exchanged (oil Cooler)	kW	-
Oil Temp. at Oil Cooler Outlet	°C	-
Certified by	-	Frascold

Certified by:

- Frascold tentative data



Legend:

- *ref: At conditions according to EN12900
- Suction gas temperature = 20 °C
- Liquid subcooling = 0 K

All data subject to change without notice

Model: V15-71Y

Refrigerant: R404A

Power supply: 400/3/50 DOL-STAR

Dimensions:

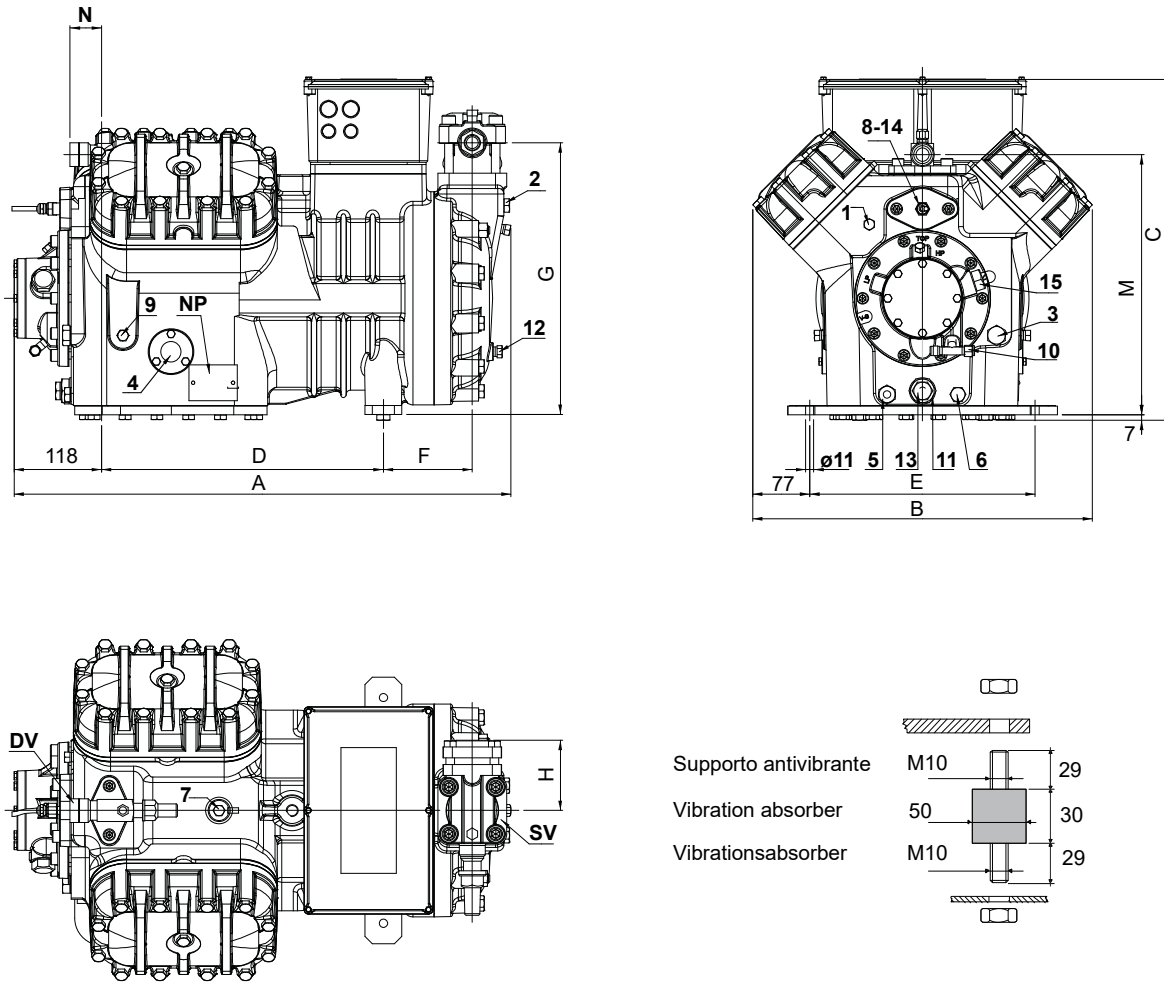

Legend:

SV: Suction Valve	1 5/8" in - 42 mm	2: Low pressure connection	1/4" NPT
DV: Discharge valve	1 1/8" in - 28,575 mm	3: Oil charge plug	3/8" GAS
A: Length	672 mm	4: Oil level sight glass	-
B: Width	460 mm	5: Crankcase heater seat	-
C: Height	463 mm	6: Oil drain plug	1/4" GAS
D: Base mounting	381 mm	7: Liquid injection plug	1/8" NPT
E: Base mounting	305 mm	8: Liquid injection sensor plug	1/8" NPT
F: Suction Valve	120 mm	9: Oil pressure switch connection (LP)	1/4" NPT
G: Suction Valve	367 mm	10: Oil pressure switch connection (HP)	1/4" SAE
H: Suction Valve	95 mm	11: Oil filter	3/8" GAS
L: Discharge valve	152 mm	12: Oil return plug	1/4" NPT
M: Discharge valve	352 mm	14: Max discharge temperature sensor connection	-
N: Discharge valve	43 mm	15: Electronic oil pressure switch connection	3/4 UNF
1: High pressure connection	1/8" NPT	NP: Nameplate	-

All data subject to change without notice