

HXK70AA KAPPA LBP Compressor Superior Efficiency R600a 220-240V 50Hz

General

Code number	CDO00110
Approvals	EN 60335-2-34 w. Annex AA
Compressors on pallet	100

Application

Application	LBP		
Frequency	Hz	50	60
Evaporating temperature	°C	-35 to -5	-
Voltage range	V	187 to 264	-
Max. condensing temperature continuous (short)	°C	60 (70)	-
Max. winding temperature continuous (short)	°C	130 (130)	-

Cooling requirements

Frequency	Hz	50			60		
Application		LBP	MBP	HBP	LBP	MBP	HBP
32°C		S	-	-	-	-	-
38°C		S	-	-	-	-	-
43°C		S	-	-	-	-	-
Remarks on application:							

Motor

Motor type	RSCR		
LRA (rated after 4 sec. UL984), HST LST	A	-	2.48
Cut in Current, HST LST	A	-	3.16
Resistance, main start winding (25°C)	Ω	37.8	29.4

Design

Displacement	cm ³	6.64
Oil quantity (type)	cm ³	165 (mineral)
Maximum refrigerant charge	g	150
Free gas volume in compressor	cm ³	1660
Weight without electrical equipment	kg	8.2

Dimensions

Height	mm	A	167.0
		B	173.5
Suction connector	location/I.D. mm angle	C	6.15 35°
	material comment		Copper Rubber plug
Process connector	location/O.D. mm angle	D	6.00 35°
	material comment		Copper Rubber plug
Discharge connector	location/I.D. mm angle	E	5.15 40°
	material comment		Copper Rubber plug
Oil cooler connector	location/I.D. mm angle	F	-
	material comment		-
Connector tolerance	I.D. mm		±0.05
Remarks:			

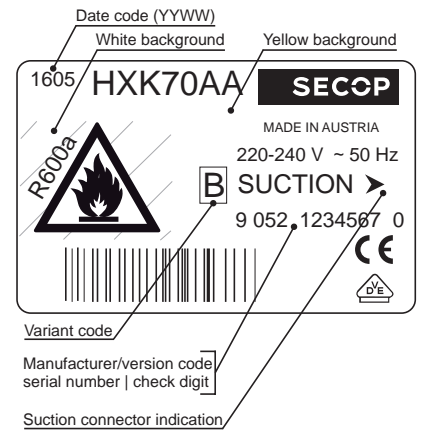

- S = Static cooling normally sufficient
- O = Oil cooling
- F₁ = Fan cooling 1.5 m/s
(compressor compartment temperature equal to ambient temperature)
- F₂ = Fan cooling 3.0 m/s necessary
- SG = Suction gas cooling normally sufficient
- = not applicable in this area

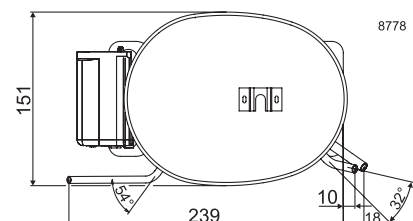
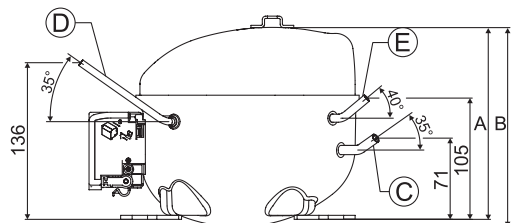
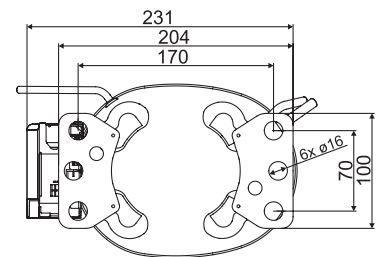

EN 12900 Household

220V, 50Hz, RC 3µF, ePTC consumption incl., static cooling (alternative use of PTC +2W)

Evap. temp. in °C	-45	-40	-35	-30	-25	-23.3	-20	-15	-10	-6.7	-5	0	5	7.2	10	15	20
Capacity in W			46.5	65.0	88.1	97.0	116	148	186	213	228						
Power cons. in W			42.8	51.1	60.5	63.9	70.7	81.5	92.6	99.9	104						
Current cons. in A			0.52	0.58	0.63	0.65	0.70	0.77	0.85	0.92	0.96						
COP in W/W			1.09	1.27	1.46	1.52	1.64	1.82	2.00	2.13	2.19						

ASHRAE LBP

220V, 50Hz, RC 3µF, ePTC consumption incl., static cooling (alternative use of PTC +2W)

Evap. temp. in °C	-45	-40	-35	-30	-25	-23.3	-20	-15	-10	-6.7	-5	0	5	7.2	10	15	20
Capacity in W			57.2	79.5	108	118	141	181	226	259	277						
Power cons. in W			43.0	51.1	60.3	63.6	70.3	80.9	91.9	99.1	103						
Current cons. in A			0.52	0.57	0.63	0.65	0.69	0.76	0.85	0.92	0.95						
COP in W/W			1.33	1.56	1.78	1.86	2.01	2.23	2.46	2.61	2.70						

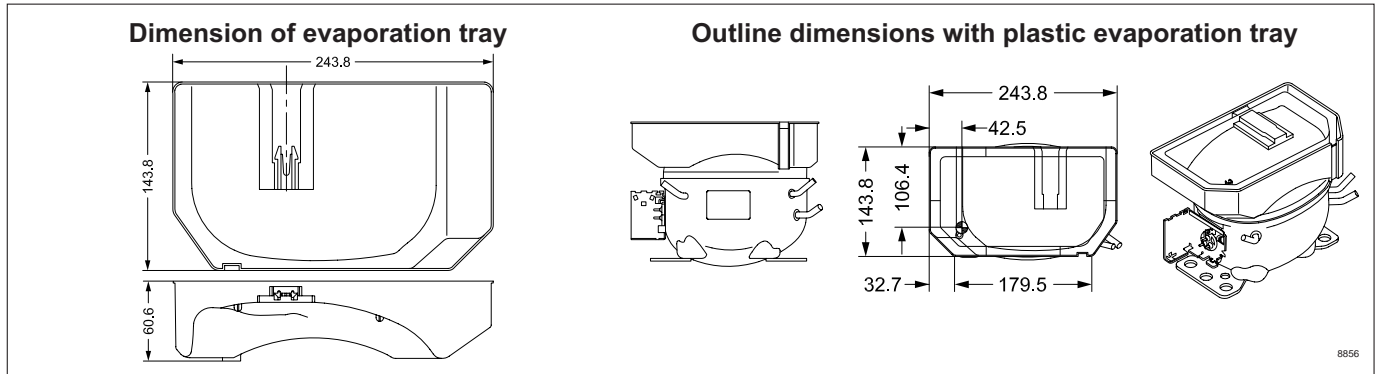
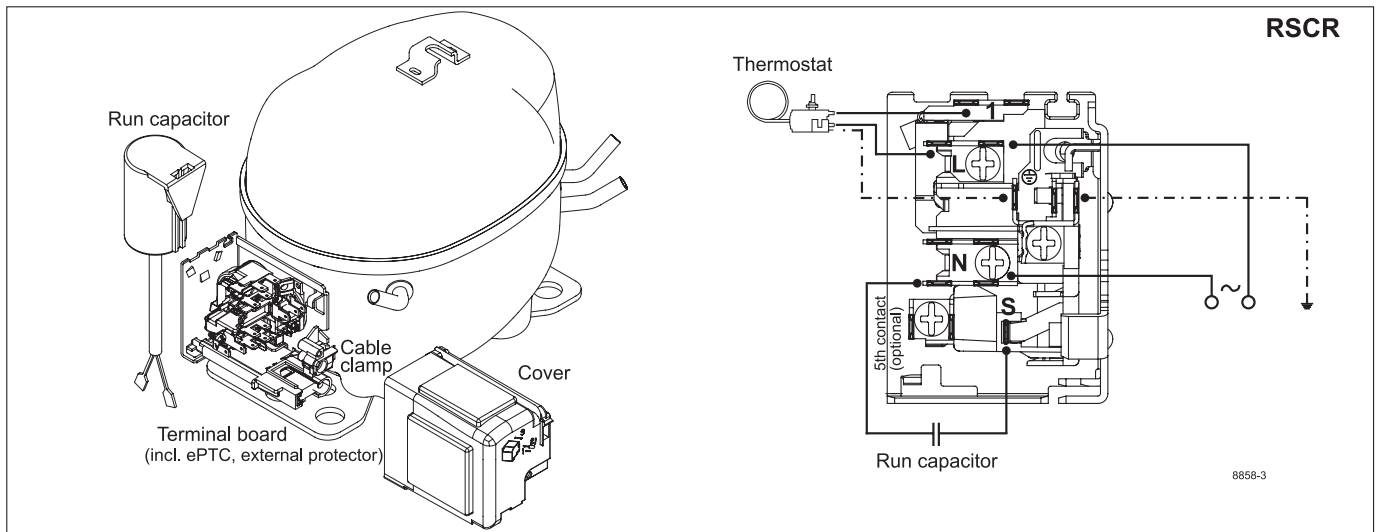

Accessories for	HXK70AA	Code number	Test conditions		
			EN 12900 Household	ASHRAE LBP	
Run capacitor (compulsory)	4.8 mm or 6.3 mm spade connectors	3 µF	Condensing temperature	55°C	54.4°C
Terminal board (incl. ePTC and external protector)	4.8 mm spade connectors	ZX F6	Ambient temperature	32°C	32.2°C
Terminal board (incl. PTC and external protector)	6.3 mm spade connectors	DA F6	Suction gas temperature	32°C	32.2°C
Motor Protector	AE 25 FJ x	F6	Liquid temperature	no subcooling	32.2°C
Cable clamp (screws not included)		113410_			
Cover		157595_			
Evaporation tray (optional)		113188_			
All-in-one equipment, e.g. 4ZN		Code number	Mounting accessories	Code number	
Cover / cable clamp + screws / earthing screw		16168000	on request, various options available		

Secop accepts no responsibility for possible errors in catalogs, brochures, and other printed material. Secop reserves the right to alter its products without notice. This also applies to products already on order provided that such alterations can be made without subsequential changes being necessary to specifications already agreed. All trademarks in this material are the property of the respective companies. Secop and the Secop logotype are trademarks of Secop GmbH. All rights reserved. www.secop.com