

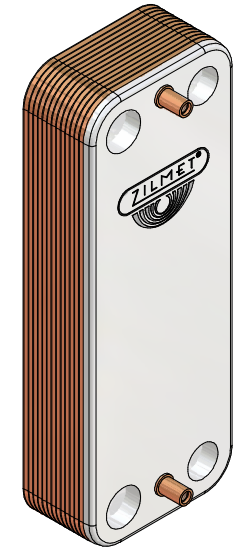

CODE	n° Plates	H
17B2071001	10	30
17B2071201	12	34
17B2071401	14	39
17B2071601	16	44
17B2071801	18	49
17B2072001	20	54
17B2072201	22	59
17B2072401	24	61
17B2072601	26	65
17B2072801	28	69
17B2073001	30	73

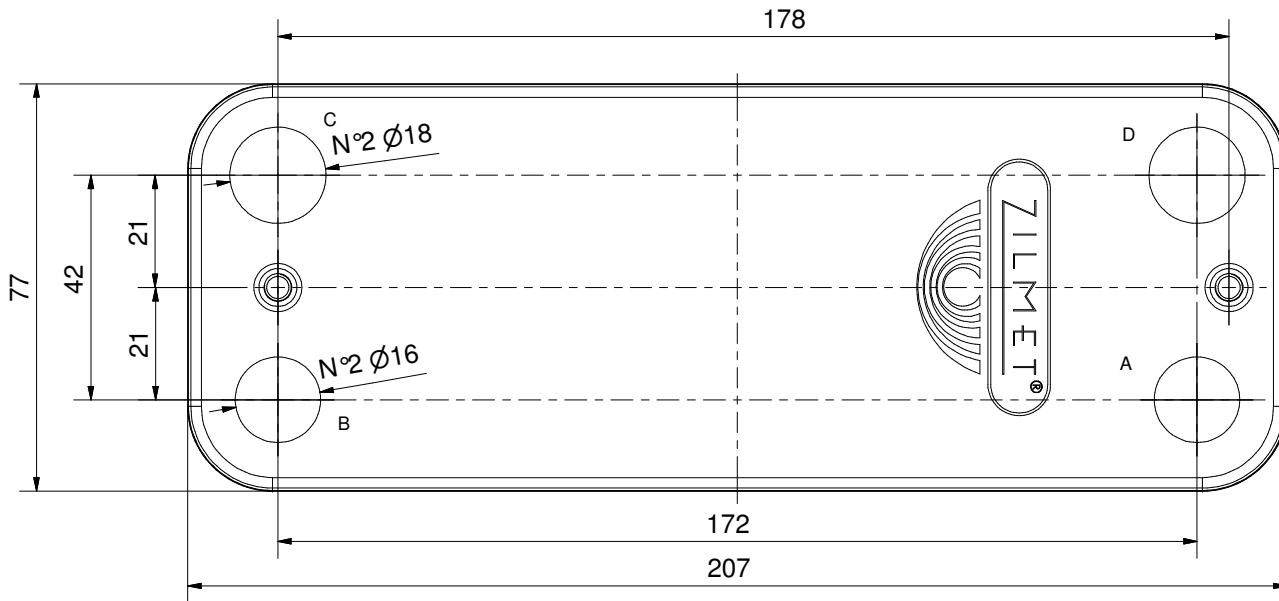

Pressione max esercizio (Max operating pressure):
 Circuito Primario (Primary circuit): 3 bar
 Circuito secondario (Secondary circuit): 8 bar
 Temperatura esercizio (Max operating temperature): -10/+99°C
 Materiale (Material): INOX AISI 316L
 Materiale di brasatura (Brazing material): 99.9% Cu

CIRCOLAZIONE FLUIDI CIRCUITO PRIMARIO ENTRATA IN C - USCITA IN D (PRIMARY CIRCUIT IN C - OUT D)
CIRCUITO SECONDARIO ENTRTA IN A - USCITA IN B (SECONDARY CIRCUIT SANITARY IN A - OUT B)

 35010 Limena (PD) Via del Santo 242 tel.049/8840662	DIS. N° / DRAWING N° ZB 207			CODICE / CODE 17B207--01
	Denominazione / Denomination HEATING HEXCHANGER	Drawn Checked Approved	Date Date Date	
Disegno di proprietà della Zilmet S.p.A. Tutti i diritti riservati. / This drawing is property of company ZILMET S.p.a. All rights reserved.				