

Q.tà **Descrizione**1 **MAGNA1 50-120 F****Attenzione: le foto e i disegni sono solo indicativi**Codice prodotto: [99221336](#)

The Grundfos MAGNA1 circulator pump is the simple option for a job well done.

With its high energy efficiency the product lives up to the EuP 2015 regulations ensuring substantial savings on electricity, and with its intuitive, user-friendly interface and maintenance-free design, MAGNA1 is the ideal circulator pump for basic performance needs in applications where basic system control and monitoring are desired.

With this range of circulator pumps, everything from setup to basic control and monitoring are made easy. The pump is maintenance-free due to the canned-rotor type design.

MAGNA1 offers the possibility of monitoring the pump via the fault relay output. The digital start/stop input remotely controls the pump.

The pump communicates wirelessly with the Grundfos GO Remote app.

MAGNA1 can work as main pump in both heating and cooling applications, including:

- Mixing loops
- Heating surfaces
- Air-conditioning surfaces
- Ground-source heat pump systems
- Smaller chiller applications.

MAGNA1 is a single-phase pump and characterised by having the controller and operating panel integrated in the control box.

The pump housing is available in both cast-iron and stainless-steel versions.

The composite rotor can be carbon-fibre reinforced, the bearing plate and rotor cladding are made of stainless steel and the stator housing is made of aluminium.

The power electronics are air-cooled.

The pump incorporates a 4-pole synchronous, permanent-magnet motor (PM motor). This motor type is characterised by higher efficiency than a conventional asynchronous squirrel-cage motor. The pump speed is controlled by an integrated frequency converter.

99221336 MAGNA1 50-120 F

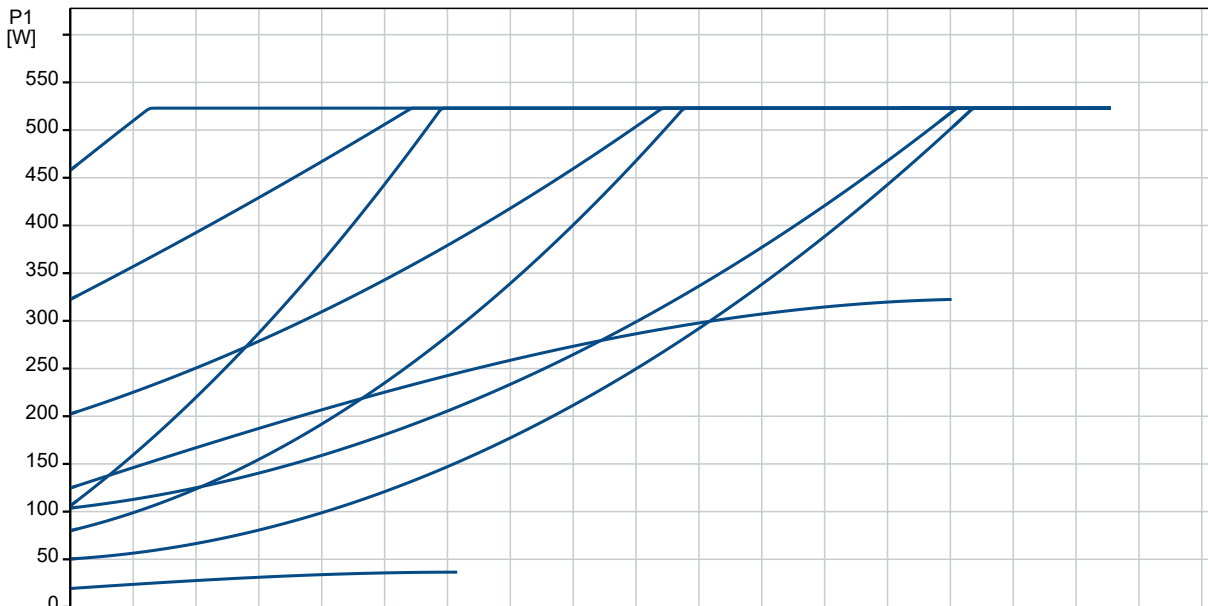
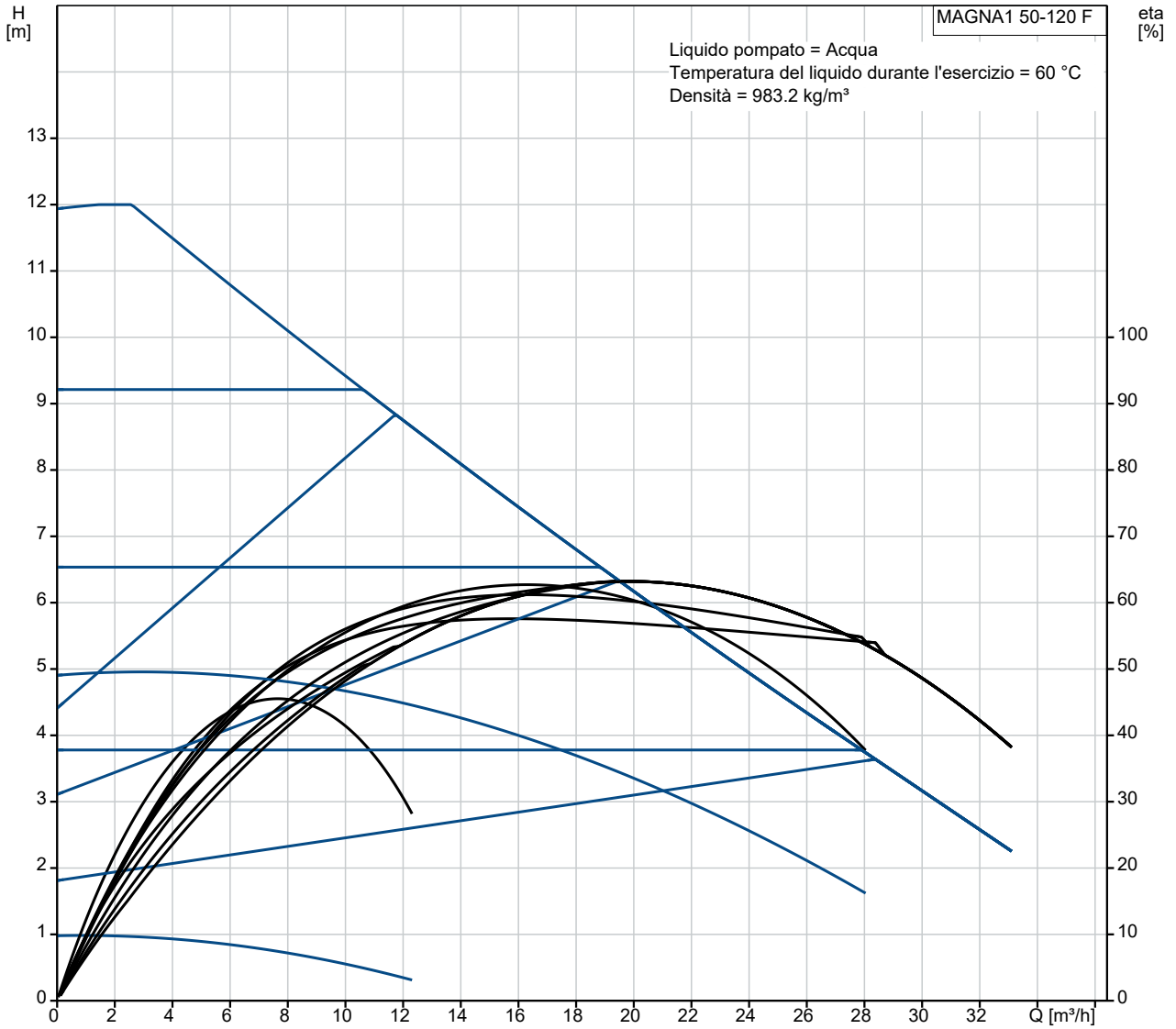

Descrizione	Valore
Informazioni generali:	
Nome prodotto:	MAGNA1 50-120 F
Codice prod.:	99221336
Codice EAN:	5712608943096
Tecniche:	
Testata max:	120 dm
Classe TF:	110
Approvazioni sulla targhetta:	CE,VDE,EAC,CN ROHS,WEEE
Modello:	C
Materiale:	
Corpo pompa:	Ghisa
Corpo pompa:	EN-GJL-250
Corpo pompa:	ASTM A48-250B
Girante:	PES 30%GF
Installazione:	
Limite temperatura ambiente:	0 .. 40 °C
Max pressione di funzionamento:	10 bar
Flangia standard:	DIN
Attacco tubazione:	DN 50
Pressione d'esercizio:	PN 6/10
Interasse:	280 mm
Liquido:	
Liquido pompato:	Acqua
Gamma temperatura del liquido:	-10 .. 110 °C
Temperatura del liquido durante il funzionamento:	60 °C
Densità:	983.2 kg/m ³
Dati elettrici:	
Ingr. pot. - P1:	20.2 .. 533 W
Frequenza di rete:	50 / 60 Hz
Tensione nominale:	1 x 230 V
Consumo massimo di corrente:	0.22 .. 2.37 A
Classe di protezione (IEC 34-5):	X4D
Classe di isolamento (IEC 85):	F
Altro:	
Energy (EEI):	0.20
Peso netto:	18 kg
Peso lordo:	19.9 kg
Volume imballo:	0.046 m ³
Finlandese:	4615196
Nazione di origine:	DE
Tariffa convenzione n.:	84137030

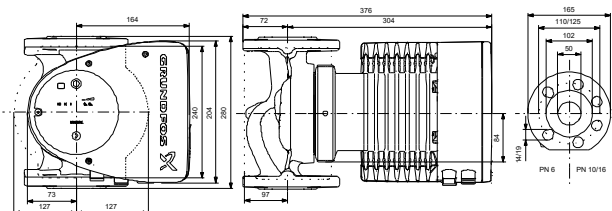
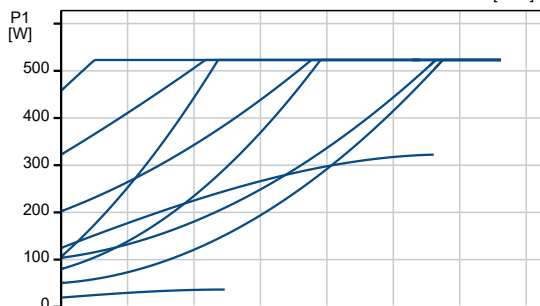
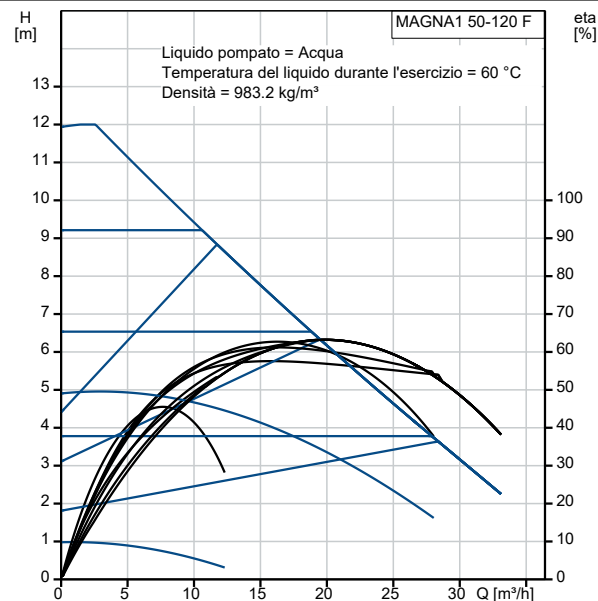

Example of mains-connected motor with mains switch, backup fuse and additional protection

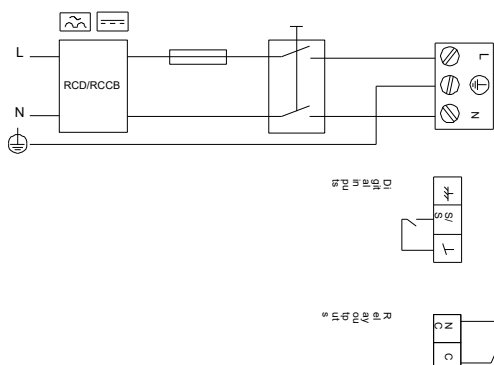

99221336 MAGNA1 50-120 F

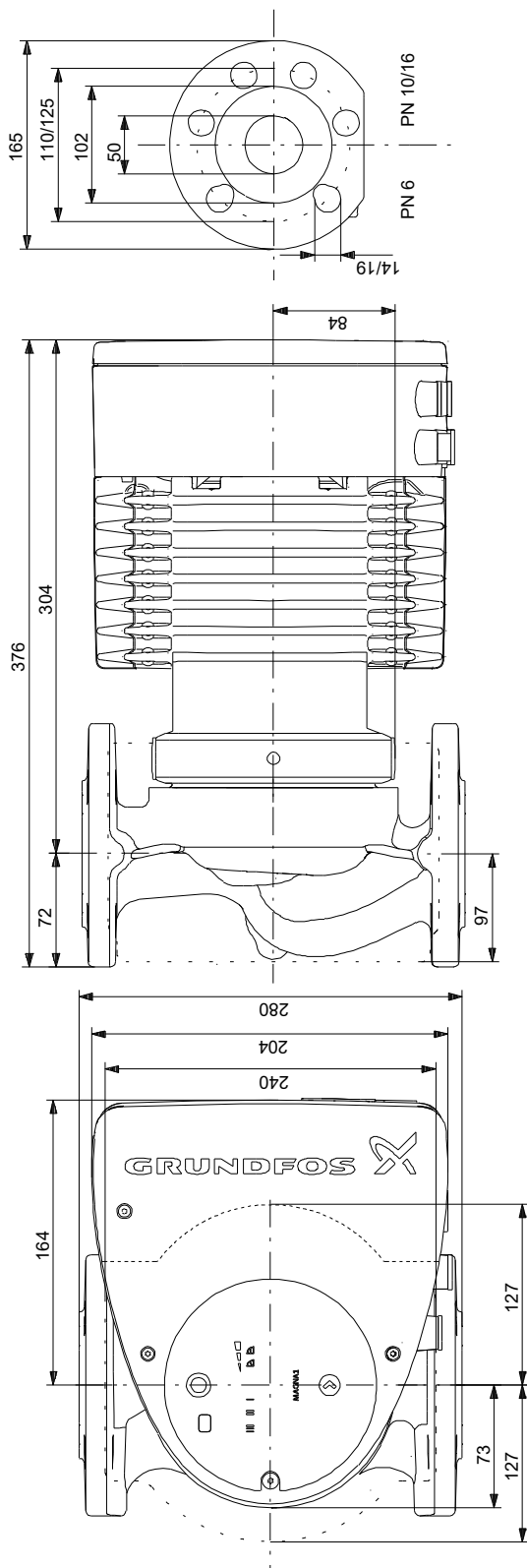

Nota: tutte le misure sono in mm se non diversamente specificato.
Attenzione: il disegno dimensionale semplificato non mostra tutti i dettagli.

99221336 MAGNA1 50-120 F

Example of mains-connected motor
with mains switch, backup fuse and additional protection

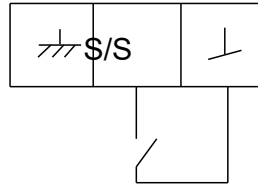

Digital inputs

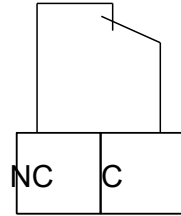

Relay outputs