

Making Your Job More Enjoyable

Cordless Vacuum Pump

VRP-2DLi / VRP-4DLi



VALUE Mechanical & Electrical Products CO., LTD

Add: Jiulong Avenue, Western Industrial District, Wenling, Zhejiang, China

Tel: +86-576-86191959

Fax: +86-576-86191957

Email: value@worldvalue.cn

www.worldvalue.cn

VALUE • Quality Assurance



NAVTEK[™]
High-end Series

CONTENT

I. Pump Configuration, Specification, Features	01
II. Charger Specification	02
III. Preparation	03
IV. Operation, Maintenance	03
V. Troubleshooting	06
VI. Dimension	07

Warning:

- 1.To prevent injuries, read and follow this manual carefully.
- 2.Wear goggles during refrigerant work.
- 3.Do not come in direct contact with refrigerant.
- 4.Do not touch oil tank and motor while operating.

I. Pump Configuration, Specification, Features

Configuration

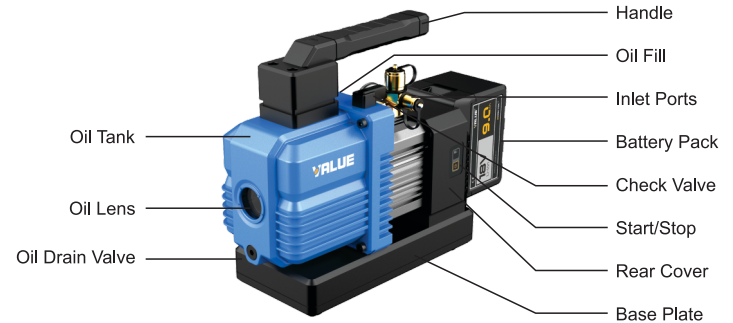

Specification

Model	VRP-2DLi	VRP-4DLi
Flow Rate	2 CFM	4 CFM
	57 L/Min	114 L/Min
Ultimate Vacuum	23 micron	15 micron
Pump Design	Double stage	Double stage
Inlet Port	1/4"SAE	1/4"SAE & 3/8"
Oil Capacity	160 ml	260 ml
Battery	18V 5Ah	18V 9Ah
Running time	50 min	50 min
Dimensions	233x90x190 mm	320x112x242 mm
Rough weight	3.2kg	7kg

Features:

1. Integrated pump structure to get better vacuum level
2. Forced oil lubrication ensures vane sealing, cooling, high reliability
3. Large oil lens to prevent oil shortage
4. Ignition proof design with electronic starter
5. DC motor to be lighter, smaller
6. Li-ion battery to be more convenient

Charger Operation

1. Charge indoors.
2. For use with VALUE VB518,VB918 battery pack only.
3. Battery could be charged or disconnected anytime.
4. Push battery into port until it engages with lock.
5. A tone is played when charge starts or completes.
6. When charge is complete, press the lock and pull out the battery.
7. Indicate light is on during charging.

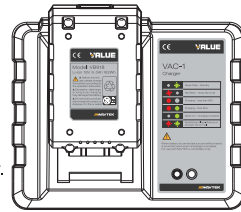

Light Indicator

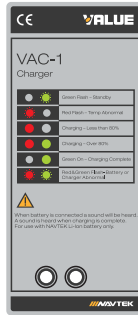

Warning

1. Don't expose charger to rain or water.
2. This charger is only for VB518,VB918 battery. Don't charge any other type of battery.
3. Keep the charger clean.
4. Check the charger before using.
5. Do not use in a flammable environment.
6. Disconnect the power cord when not in use.
7. This charger is only for professionals to operate.
8. This charger should only be repaired by qualified individuals. Please contact VALUE for charger service.

III. Preparation

1. Before initial use, please charge battery to full capacity.
2. Unscrew the oil fill cap. Fill oil to the middle level of lens. Start the pump to run for 1 minute. Add oil if its level is low.

Note:

1. Fill oil slowly to prevent oil spill.
2. Low oil will affect performance. Too much oil will cause mist spray.



IV. Operation, Maintenance

Pump Operation

1. Connect the vacuum pump to the system to be evacuated.
Open the check valve.
2. Check the seal to assure there is no leak.
3. After the evacuation work, stop pump and close the system valve.
4. Disconnect the hoses.
5. Cap the inlet ports to prevent particle falling into pump.

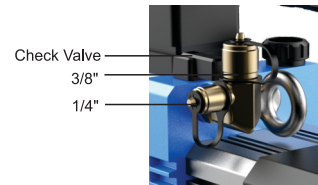

VRP-4DLi

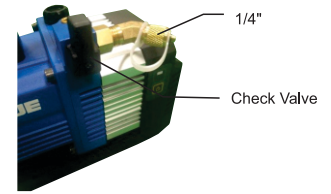

VRP-2DLi

Note:

1. Check oil during operation, if oil is low add it immediately.
2. Pump starts at 3800 rpm and after 10 minutes it lowers to 3000 rpm.
3. When the battery is full, it's 21V. When it lowers down to around 16V, it starts beep. It is suggested to close the valve on the vacuum or system to hold the vacuum once the alert begins. You will have 3 minutes to close the valves once the alert begins to beep before the battery runs out.

Warning

1. Don't run pump over 3 minutes when it's open to atmosphere.
2. Recover the refrigerant before evacuation.

Maintenance

1.Pump Oil

Oil type and condition is an important factor for the vacuum level. To get the best performance,it is recommended to use VALUE pump oil.

Ti: Change oil immediately when it becomes cloudy or dirty.

2.Oil Change

2.1 If pump is cold, run pump for 1 minute.

2.2 Open the inlet when running pump, to get the oil out of the pump cylinder. Stop the pump and then open the oil drain valve. Dispose the oil according to local regulation. Tilt the pump to drain the residual oil.

2.3 Screw back the oil drain valve.

2.4 Open the oil fill cap to fill oil.

EXPLODED VIEW

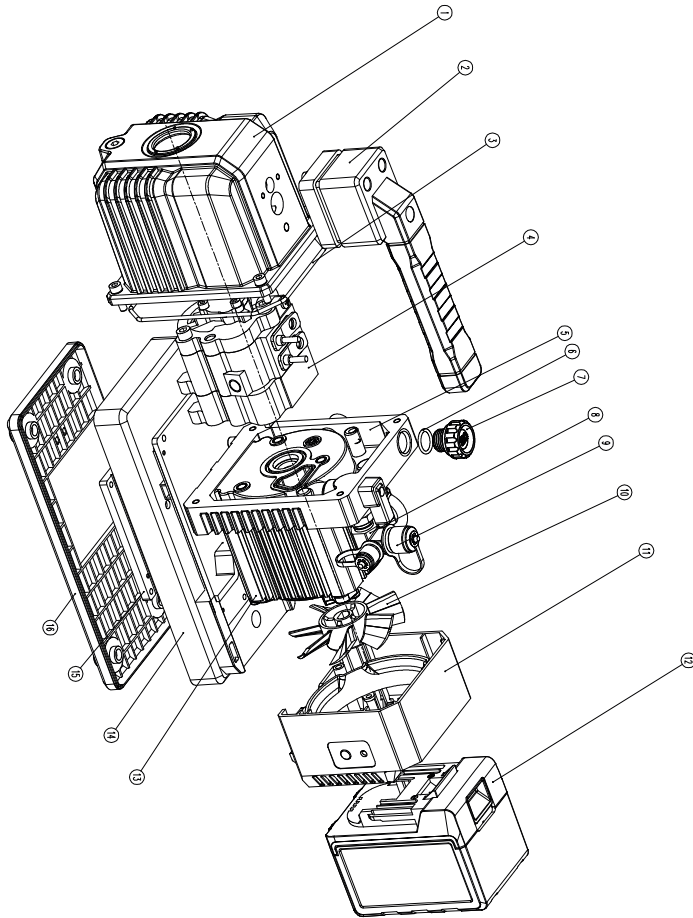

REPAIR PARTS LIST

Ref No.	VRP-2DLi	VRP-4DL	Part Name
1	P02001	P04001	Oil Tank
2	P02002	P04002	Handle
3	P02003	P04003	O-ring
4	P02004	P04004	Pump Cylinder Assy
5	P02005	P04005	Trestle
6	P02006	P04006	O-ring
7	P02007	P04007	Oil Fill
8	P02008	P04008	Inlet Port
9	P02009	P04009	Cap
10	P02010	P04010	Fan
11	P02011	P04011	Rear Cover Assy
12	VB518	VB918	Battery Pack
13	P02013	P04013	Motor
14	P02014	P04014	Base Plate
15	P02015	P04015	Controller Assy
16	P02016	P04016	Cover Plate

V. Troubleshooting

Malfunction	Possible Cause	Remedy
Low Vacuum	1. Secondary air inlet connection cap loose on the air inlet port.	Tighten the cap.
	2. Damaged rubber ring inside the secondary air inlet connection cap.	Replace the rubber ring.
	3. The volume of oil is insufficient.	Add oil to the center line of the oil display.
	4. Pump oil becomes opaque or absorbed too many impurities.	Replace with new oil.
	5. The pump's oil entry hole is clogged or the oil supply is insufficient.	Clean the oil entry hole, clean the oil filter.
	6. The pump connecting hoses, manifold or system has a leak.	Inspect the connecting hose gaskets and system, repair leaks.
	7. The pump selection is wrong.	Check the size of the container to be evacuated, recalculate and select an appropriate pump model.
	8. The pump has been used for too long, damage and wear to components caused increased gaps between parts.	Inspect and repair, or replace the pump.
Oil leak	1. Damaged oil seal.	Replace the oil seal.
	2. Loose or damaged oil box connections.	Tighten the connecting screws, replace O-rings.
Oil spray	1. Excessive oil volume.	Remove oil until the oil position line is reached.
	2. Inlet port pressure is excessively high for a long period.	Select an appropriate pump, increase the pumping speed.
Start-up problems	1. Oil temperature is too low.	Exposed the air entry hole to the external atmosphere, and remove the oil fume filtration device. Use a screwdriver to turn the engine axle in an anti-clockwise direction.
	2. Motor, power source or circuit board malfunctions.	Inspect and repair.
	3. Foreign objects entered the pump.	Inspect and remove.
	4. Voltage supply is excessively low or high.	Inspect the power source voltage.
	5. Overload trips.	After overload trip occurs, switch kept On. Remove the power plug, wait for approximately 30 seconds before inspecting and repairing.

Notes:

1. The pump is inverter driven and the motor has over-current / overload protection, please troubleshoot after overload resets.
2. If the above methods cannot resolve your problems, please contact your nearest distributor or take the pump to a repair center. We will do our best to provide you with a quick turnaround to keep you working.

Requirements For Warranty Coverage

Product warranty is provided for product quality problems for two years from date of sale. For warranty to be valid, the following conditions must be met:

1. Products issues due to manufacturing defects confirmed by qualified agents.
2. Products which have not been maintained or dismantled by unauthorized parties.
3. Products that have been used in accordance with the User Manual. All maintenance services shall be performed during the warranty period.

Statement: Other than repairing the product defective, the manufacturer of this product will not be liable for any other costs, such as time spent in fixing the issue, refrigerant consumption, refrigerant disposal costs, as well as unauthorized transportation and labor costs.

VI. Dimension

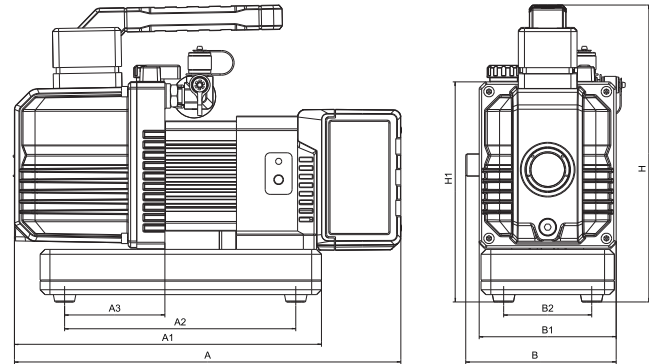

Model	A	A1	A2	A3	B	B1	B2	H	H1
VRP-2DLi	232.5	186	125	70	105	90	57	133.5	149.5
VRP-4DLi	316	251	189	82	123	112	72	242	180