

**TG 60/1 60 - 605**

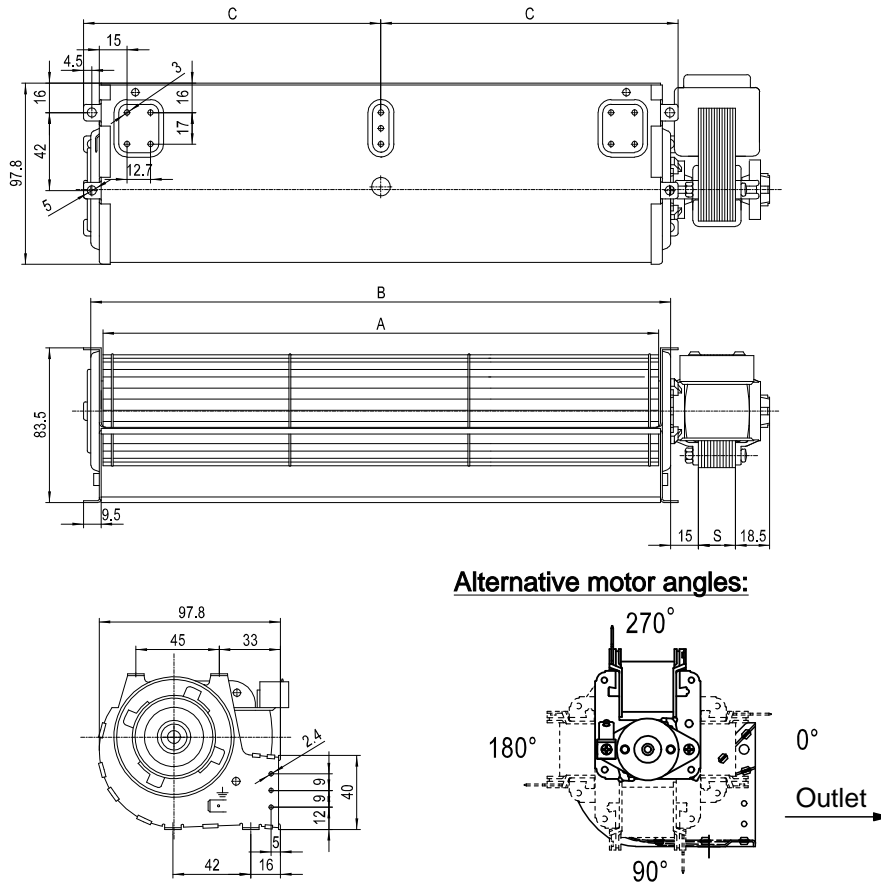

**Alternative motor angles:**

Used in a wide range of products such as ovens, pellet stoves, vending machines and refrigerators.  
 Standard for all motor types: insulation class F or H; motor available with encapsulated bobbin and/or hall sensor.  
 230V-50/60Hz alt. 120V/60Hz alt. 12/24V AC/DC.

**Stack size (S) :** 10/15/20/30/40

Blower	A	B
TG 60/1-60	60	73
TG 60/1-90	90	103
TG 60/1-120	120	133
TG 60/1-180	180	193
TG 60/1-240	240	253
TG 60/1-270	270	283
TG 60/1-300	300	313
TG 60/1-330	330	343
TG 60/1-360	360	373
TG 60/1-420	420	433
TG 60/1-480	480	493
TG 60/1-505	505	518
TG 60/1-550	550	563
TG 60/1-605	605	618

Description	
Airflow	Up to 380 m3/h
Input Power	Up to 80 W
Pressure	Up to 90 Pa
Speed	Up to 2800 RPM

**Crossflow blower description example:**

TGA 60 / 1 - 180 / 30

Crossflow blower \_\_\_\_\_

Motor pos. L (O) / R (A) \_\_\_\_\_

Wheel diameter \_\_\_\_\_

Housing's profile 1 \_\_\_\_\_

Length \_\_\_\_\_

Stack size \_\_\_\_\_