

M9304 2-Point & 3-Point Electric Damper-Actuator

Application

These Johnson Controls electric actuators have been specially developed for use with small air dampers in ventilation and air conditioning systems.

Thanks to their very small size and clever construction they are also ideal for applications where space is limited. A key feature of the design is the Johnson Controls stem adapter which also incorporates angle-of-rotation limiting and position indication.

Key Features

- 2 and 3-point control
- Load independent running time
- Paralleling of up to 5 actuators possible
- Screw terminal connections
- Universal adapter for:
 - Round shafts from 6 to 16 mm dia.
 - or adapter Z10DN... for
 - Square shafts 8, 10, 11 & 12 mm
- Direction of rotation selection
- Angle-of-rotation limiting
- Manual control by pushbutton
- 2 floating auxiliary switches
- Power saving at end stops



Type/Specifications/Technical data

M9304-AGA-1N	Damper actuator 24 VAC/VDC		
M9304-AGC-1N	Damper actuator 24 VAC/VDC with 2 adjustable auxiliary switches		
M9304-ADA-1N	Damper actuator 230 VAC		
M9304-ADC-1N	Damper actuator 230 VAC with 2 adjustable auxiliary switches		
Actuators	Units	M9304-AG.-1N	M9304-AD.-1N
Drive torque	Nm	4	4
Damper area approx.	m ²	0,8	0,8
Running time	sec	35	35
Power supply	V	24 VAC/VDC	230 VAC
Frequency	Hz	50 - 60	50 - 60
Power consumption:			
- operating	W	2.5	4.0
- at end stops	W	0.75	3.0
For wire gauge	VA/Imax	4.1/2.0A @2msec.	5.0/0.1A @1msec.
Weight	Kg	0.9	0.9
Control signals		2 and 3-point	3-point
Position signal			None
Angle-of-rotation: - range		90° (93° mech.)	
- limiting		0°...30° und 90°...60°	
Auxiliary switch rating		3 (1.5) Amp 230 V	
Service life		60'000 rotations	
Noise level		40 dB (A)	
Protection class		II	
Enclosure		IP 40	
Ambient temperature range		-20...50°C	
Ambient humidity		5...95% rH non-condensing	
Maintenance		maintenance-free	
Standards		The actuators meet CE requirements	

Subject to design modifications without notice

Wiring diagram

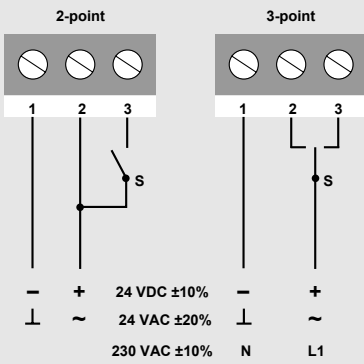

Dimensions (mm)

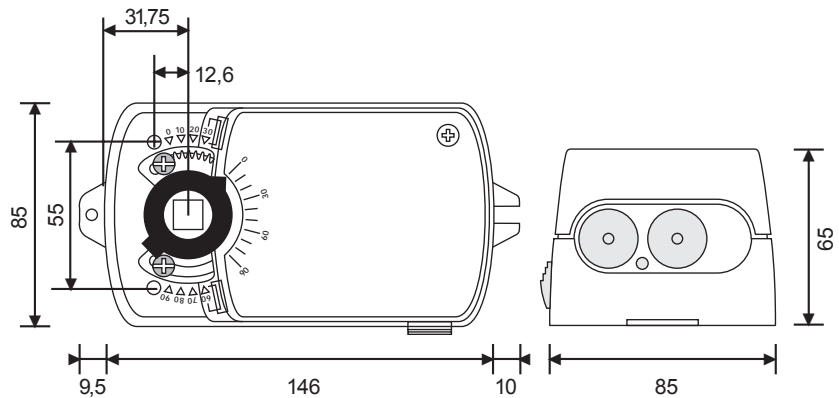

Parallel connection

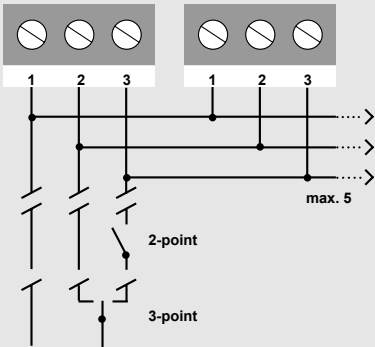

Changing direction of rotation

The direction of rotation can be changed by reversing plug c

Factory setting
Clockwise rotation.

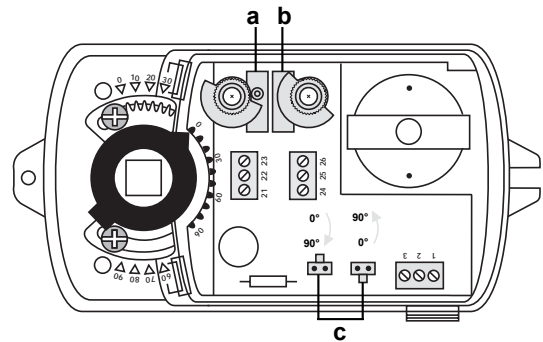

Auxiliary switches (S)

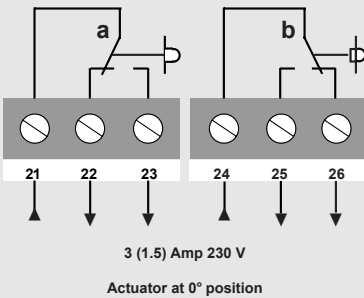

Auxiliary switch adjustment

Factory setting:
 Switch a at 10°
 Switch b at 80°

The operating points can be altered as required by simply rotating by hand.

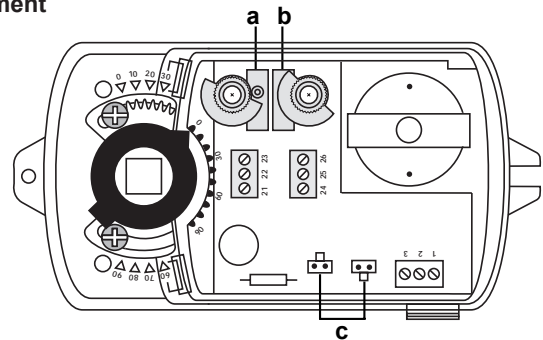

Adjusting angle-of-rotation limiting

The angle of rotation/working range of 90° can be reduced by up to 0° from each end position by means of screw 1 and 2.

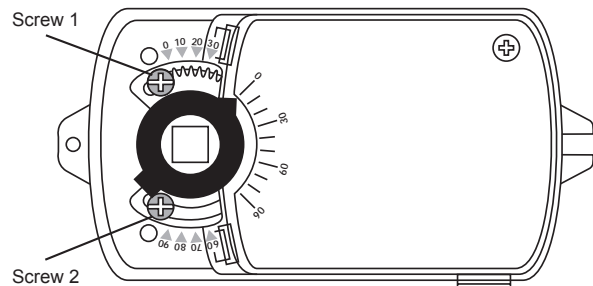

The performance specifications are nominal and conform to acceptable industrial standards. For application at conditions beyond these specifications, consult the local Johnson Controls office. Johnson Controls Incorporated shall not be liable for damages resulting from misapplication or misuse of its products

M9304 Proportional Electric Damper-Actuator

Application

These Johnson Controls electric actuators are for the adjustment of small air dampers in ventilation and air conditioning systems.

Thanks to their very small size and clever construction they are also ideal for applications where space is limited.

A key feature of the design is the Johnson Controls stem adapter which also incorporates angle-of-rotation limiting and position indication.

Key Features

- 0...10 V DC control
- Load independent running time
- Paralleling of up to 5 actuators possible
- Screw terminal connections
- Universal adapter for:
 - Round shafts from 6 to 16 mm dia.
 - or adapter Z10DN... for
 - Square shafts 8, 10, 11 & 12 mm
- Direction of rotation selection
- Angle-of-rotation limiting
- Manual control by pushbutton
- Power saving at end stops



Type designations/Specifications/Technical data

M9304-GGA-1N Damper actuator 24 VAC/VDC

Actuators	Units	M9304-GGA-1N
Drive torque	Nm	4
Damper area approx.	m ²	0.8
Running time approx.	sec	35
Power supply	V	24 VAC/VDC
Frequency	Hz	50-60
Power consumption:		
- operating	W	2.5
- at end stops	W	0.75
For wire gauge	VA/Imax	3.5/2.5A @ 2 msec
Weight	Kg	0.9
Control signal		0...10 VDC
Position signal		0...10 VDC
Angle-of-rotation: - working range		90° (93° mech.)
- limiting		0°...30° and 90°...60°
Noise level		40 dB (A)
Protection class		II
Enclosure		IP 40
Ambient temperature range		-20...50°C
Ambient humidity range		5...95% rH non-condensing
Maintenance		Maintenance free
Standard		The actuators meet CE requirements

Subject to design modifications without notice

Wiring diagram

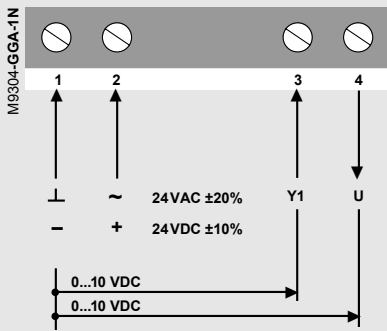

Adjusting the control signals

Control signal Y1	0...10 VDC
Input resistance	Ri > 100 kΩ
Position signal U	0...10 VDC
Load resistance	> 50 kΩ

Parallel connection

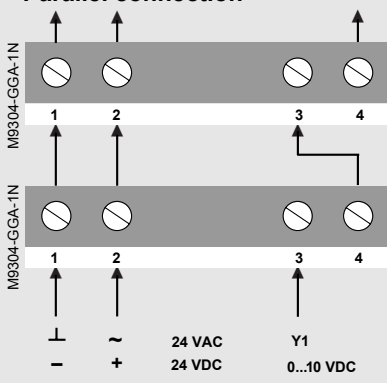

When M9304-GGA-1N actuators are to be operated in parallel, the output signal U = 0...10 VDC (Terminal 4) of the master actuator must be connected to Terminal 3 of the next slave actuator, etc.

Note:
Up to 5 actuators can be operated in parallel.

Remote positioner

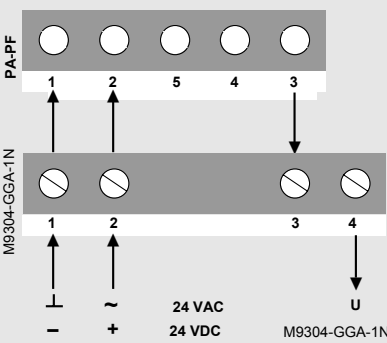

M9304-GGA-1N actuators can also be controlled by means of a Johnson Controls M9000 PA - PF Remote positioner with a control signal of 0...10 VDC (see data sheet D5.620).

Note:
Up to 5 actuators can be operated in parallel.

Override control

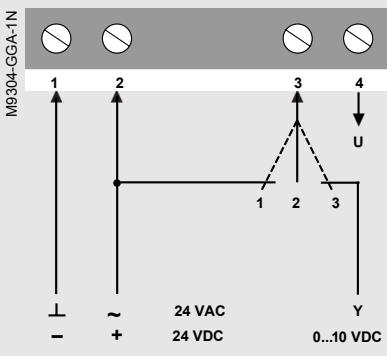

Override control of M9304-GGA-1N actuators can be provided with the circuitry shown opposite.

Switch position:
1 = Actuator runs to 10 V
2 = Actuator runs to 0 V
3 = Automatic control

Dimensions (mm)

M9000-PA in surface-mounted housing

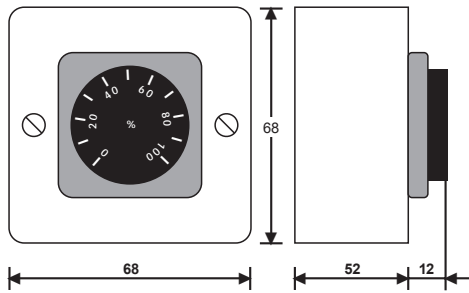

M9000-PF flush-mount assy.

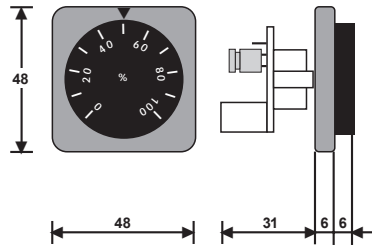

Drilling template

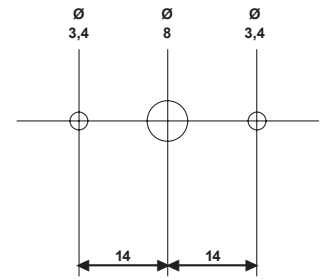

Designation/Specifications/Technical data

M9000-PA 0...100% Remote positioner for surface mounting
 M9000-PF 0...100% Remote positioner for flush mounting

For actuator	Type	M9304-GGA-1N
Power supply	V	24 VAC/VDC ±20%
Frequency	Hz	50-60
Output signal	U	0(2)...10 VDC
Output rating		for up to 5 actuators
Control signal Y1	V	0(2)...10 VDC

Wiring diagram

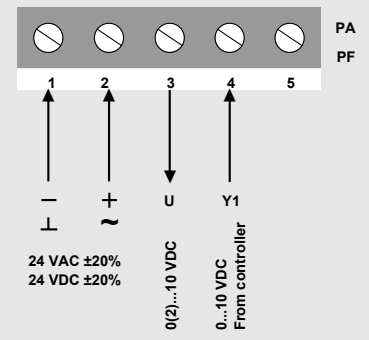

Output signal matching

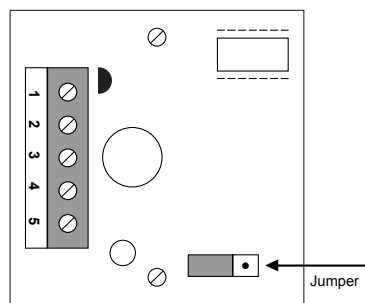

The output signal 0...10 VDC or 2...10 VDC is proportional to 0...100% rotation of the adjuster knob.

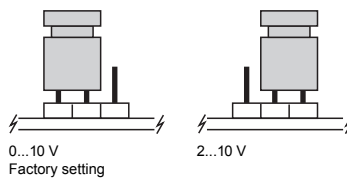

for manual control

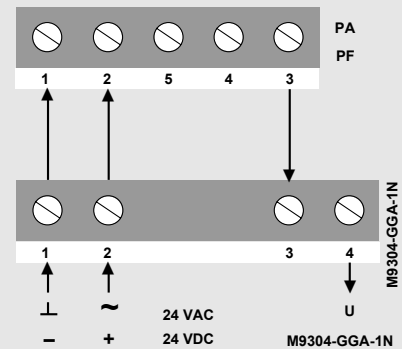

Angle-of-rotation limiting

0...100%

20...80%

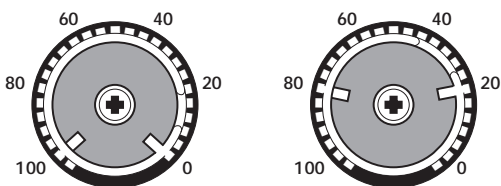

The adjuster knob can be removed by pulling it out of the front plate. Inside the knob the mechanical limiting of the angle-of-rotation can be adjusted by moving the stop springs.

Factory setting 0...100%.

for minimum limiting

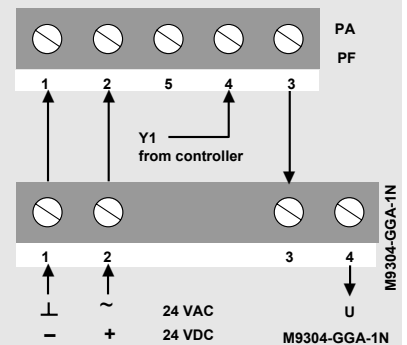

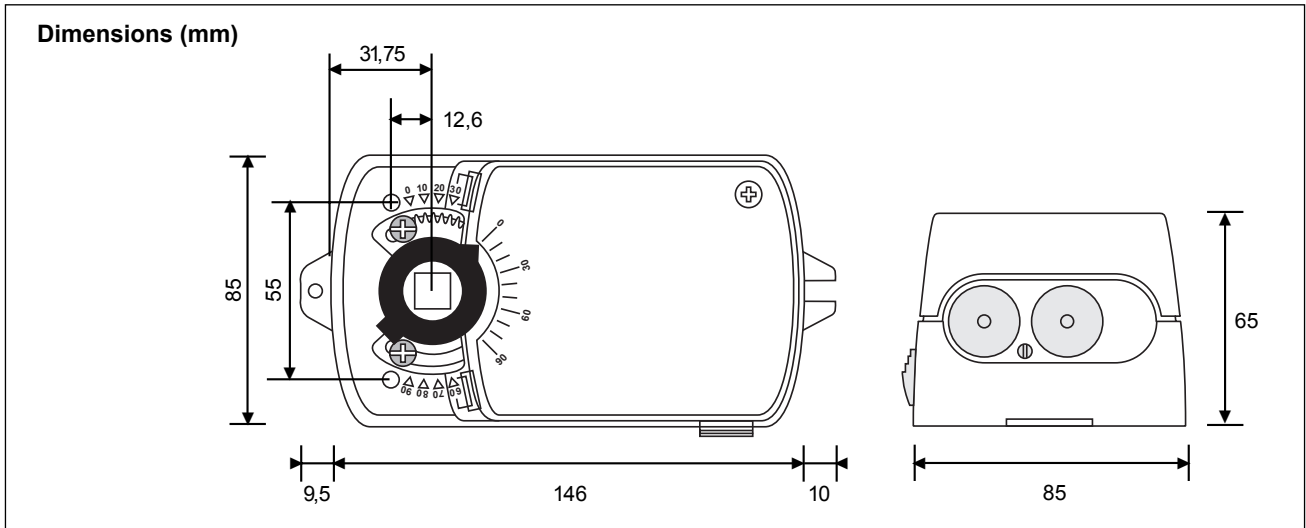

Direction of rotation

The direction of rotation can be changed by reversing plug **c**.

Factory setting: Clockwise rotation (R).

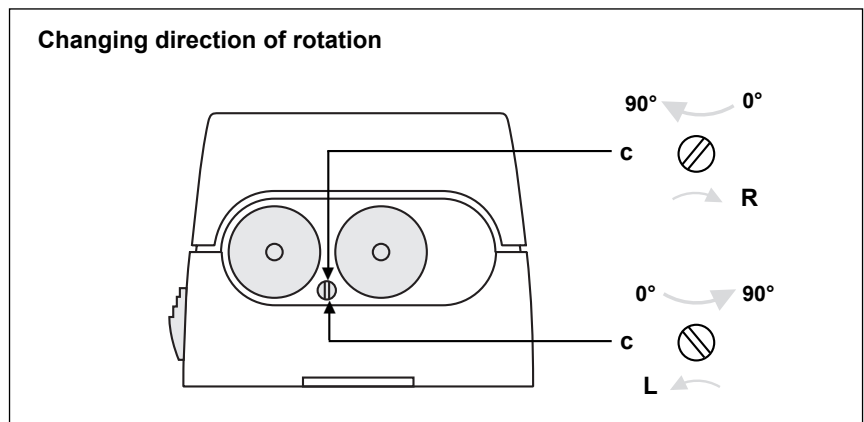

Angle of rotation

The angle of rotation/working range of 90° can be reduced by up to 30° from each end position by means of screw 1 and 2.

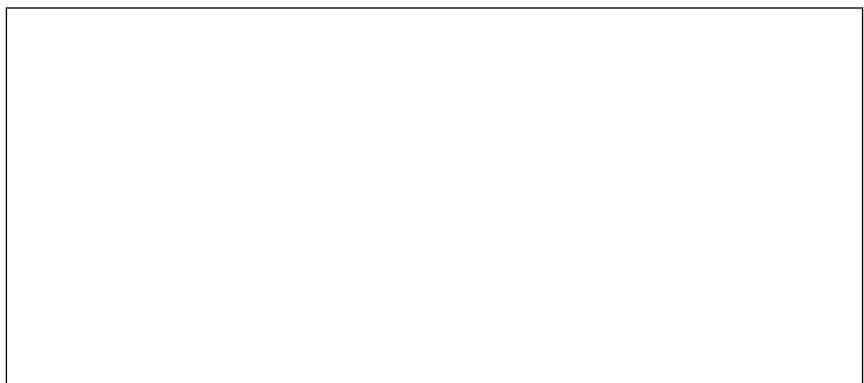
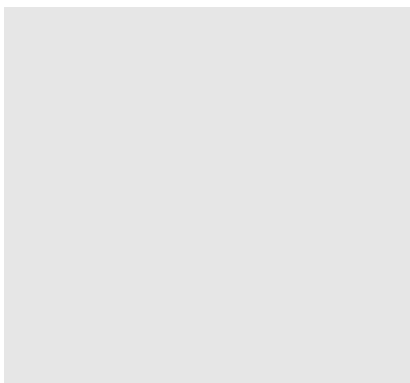
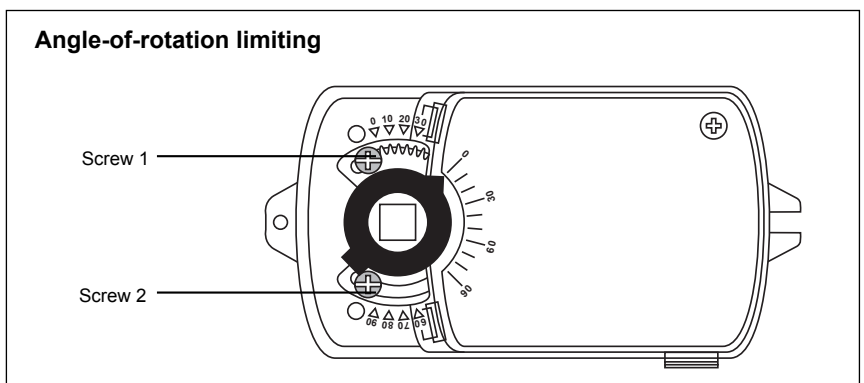

The performance specifications are nominal and conform to acceptable industrial standards. For application at conditions beyond these specifications, consult the local Johnson Controls office. Johnson Controls Incorporated shall not be liable for damages resulting from misapplication or misuse of its products