

Heating and cooling

High-efficiency pumps

Dimensions, motor data Wilo-Yonos PARA RSTG .../7.5

Front view



Rear view



Motor data

Wilo-Yonos PARA...	Speed	Power consumption 1~230 V	Current at 1~230V	Motor protection
	n	P_1	I	–
	rpm	W	A	–
RSTG .../7.5	800 - 4770	4-7.5	0.04-0.66	integrated

Materials

Wilo-Yonos PARA...	Pump housing	Impeller	Pump shaft	Bearing
RSTG .../7.5	Cast iron with cathaphoresis treatment	PP composite with GF 40%	Stainless steel	Carbon, metal impregnated

Dimensions, motor data Wilo-Yonos PARA RSTG .../7.5

Dimension drawing

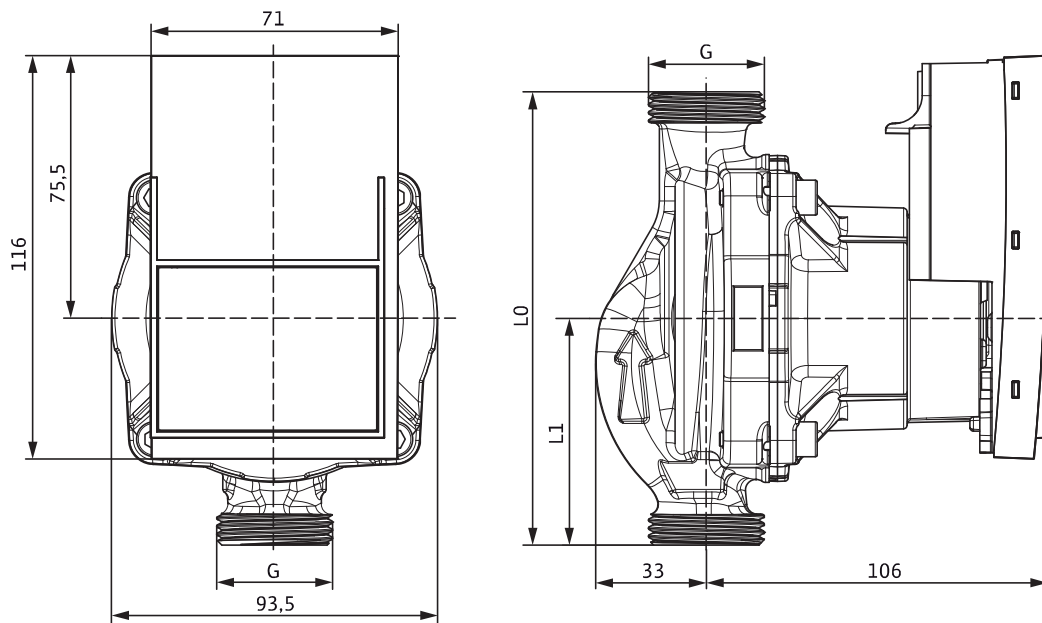

Dimensions, weights

Wilo-Yonos PARA...	Threaded pipe union	Thread	Overall length	Dimensions	Weight approx.
		–	l_0	$L1$	m
		–	mm		kg
RSTG 15/7.5	Rp 1/2	G 1	130	65	1.8
RSTG 25/7.5	Rp 1	G 1 1/2	130	65	1.8
RSTG 25/7.5	Rp 1	G 1 1/2	180	90	1.8
RSTG 30/7.5	Rp 1 1/4	G 2	180	90	1.8

Heating and cooling

High-efficiency pumps

Pump curves Wilo-Yonos PARA RSTG .../7.5

Wilo- RSTG 15/7.5, 25/7.5, 30/7.5

$\Delta p-v$ (variable)

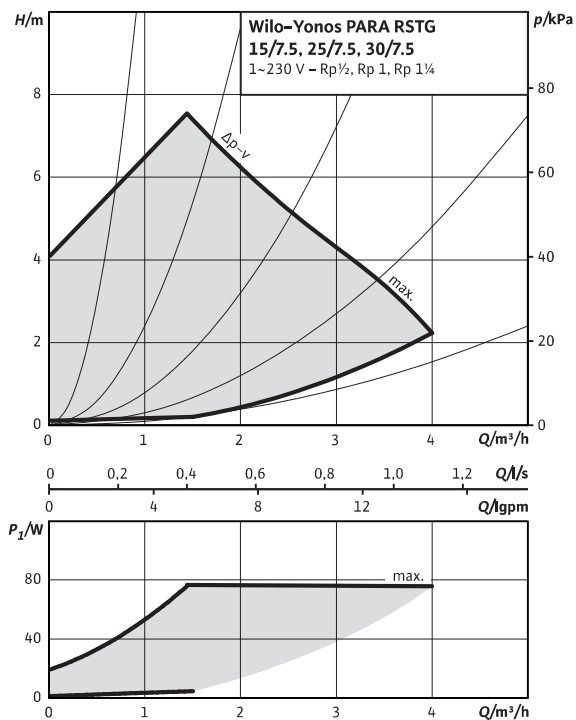

Wilo- RSTG 15/7.5, 25/7.5, 30/7.5

Constant speed I, II, III

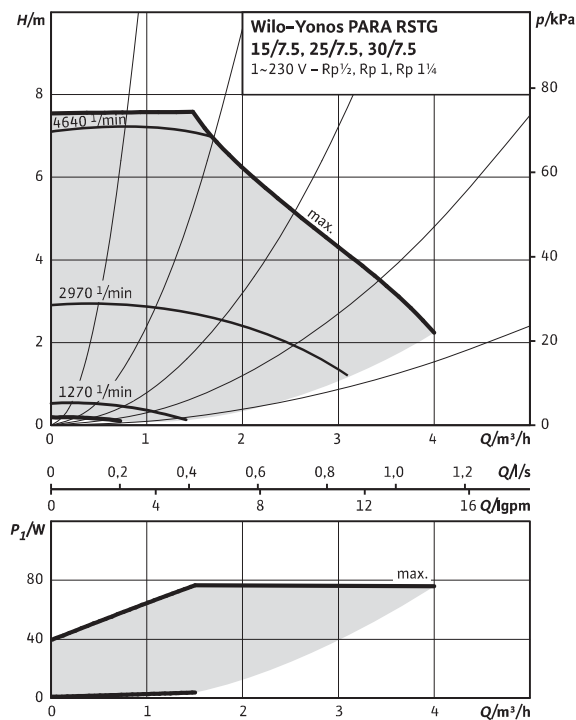

Wilo- RSTG 15/7.5, 25/7.5, 30/7.5

External control via PWM 1

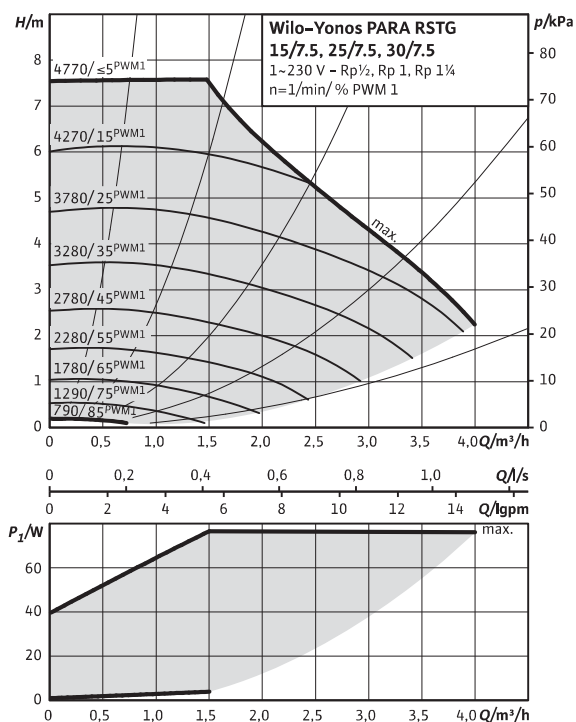

Wilo- RSTG 15/7.5, 25/7.5, 30/7.5

External control via PWM 2

