

Data sheet

Solenoid valve

Types EVR 2 - EVR 40 NC/NO

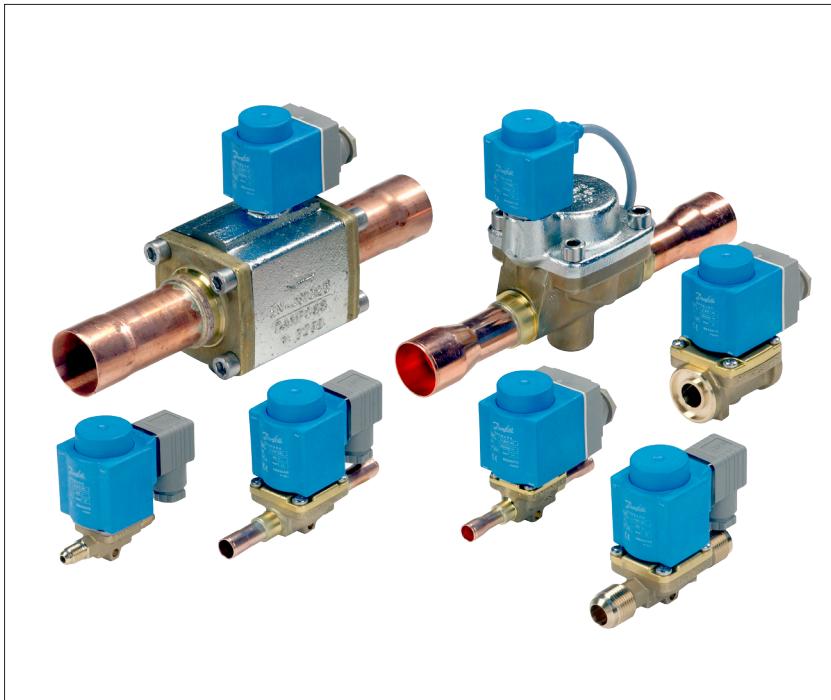

EVR is a direct or servo operated solenoid valve for liquid, suction, and hot gas lines with fluorinated refrigerants.

EVR valves are supplied complete or as separate components, i.e. valve body, coil and flanges, if required, can be ordered separately.

Features

- Complete range of solenoid valves for refrigeration, freezing and air conditioning plant
- Supplied in versions normally closed (NC) and normally open (NO) with de-energized coil
- Wide choice of coils for AC and DC
- Suitable for all fluorinated refrigerants, including flammable refrigerants
- Designed for media temperatures up to 105 °C
- MOPD up to 25 bar with 12 W coil
- Flare connections up to $\frac{5}{8}$ in
- Solder connections up to $2\frac{1}{8}$ in
- Extended ends on solder versions make the installation easy. It is not necessary to dismantle the valve when soldering in
- Available in flare, solder and flange connection versions

Approvals

Det norske Veritas, DNV

Pressure Equipment Directive (PED) 97/23/EC

Low Voltage Directive (LVD) 2006/95/EC

Polski Rejestr Statków, Polen

Maritime Register of Shipping, MRS

Versions with UL approval can be supplied to order.

Table of contents	Technical data.....	2
	Rated capacity [kW]	3
	Ordering	4
	Capacity, Liquid	7
	Capacity, Suction.....	11
	Capacity, Hot gas.....	19
	Design	40
	Function.....	42
	Material specifications	43
	Dimensions and weights.....	45

Technical data

Refrigerants
R22/R407C, R404A/R507, R410A, R134a, R407A, R23, R32, R290, R600 and R600a.
For other refrigerants, please contact Danfoss.

Note:
Only EVR 2 - EVR 20 with solder connections and without manual stem are suitable for R32, R290, R600 and R600a.

Temperature of medium
-40 – 105 °C with 10 W or 12 W coil.
Max. 130 °C during defrosting.

Ambient temperature and enclosure for coil
See separate data sheet for coils and ATEX coils.

Capacity
The capacity of the valve depends on the flow direction, see K_v values from the table.

See extended capacity tables later in this data sheet.

Type	Opening differential pressure with standard coil Δp [bar]				Temperature of medium [°C]
	Min.	Max. (= MOPD) liquid ²⁾			
		10 W [AC]	12 W [AC]	20 W [DC]	
EVR 2	0.00	25	—	18	-40 – 105
EVR 3	0.00	21	25	18	-40 – 105
EVR 6	0.05	21	25	18	-40 – 105
EVR 6 NO	0.05	21	21	21	-40 – 105
EVR 10	0.05	21	25	18	-40 – 105
EVR 10 NO	0.05	21	21	21	-40 – 105
EVR 15	0.05	21	25	18	-40 – 105
EVR 15 NO	0.05	21	21	21	-40 – 105
EVR 20 with AC coil	0.05	21	25	13	-40 – 105
EVR 20 with DC coil	0.05	—	—	16	-40 – 105
EVR 20 NO	0.05	19	19	19	-40 – 105
EVR 22	0.05	21	25	13	-40 – 105
EVR 22 NO	0.05	19	19	19	-40 – 105
EVR 25 ³⁾	0.20	21	25	18	-40 – 105
EVR 32 ³⁾	0.20	21	25	18	-40 – 105
EVR 40 ³⁾	0.20	21	25	18	-40 – 105

¹⁾The K_v value is the water flow in [m³/h] at a pressure drop across valve of 1 bar, $\rho = 1000 \text{ kg/m}^3$.

³⁾Min. diff. pressure 0.07 bar is needed to stay open.

²⁾MOPD (Max. Opening Pressure Differential) for media in gas form is approx. 1 bar greater.

Rated capacity [kW]

	R22/R407C	R134a	R404A/R507	R32	R290	R600	R600a
Liquid							
EVR 2	3.22	2.98	2.18	4.51	3.58	4.06	3.61
EVR 3	5.43	5.02	3.68	7.61	6.05	6.84	6.09
EVR 6	16.09	14.89	10.9	22.55	17.91	20.28	18.04
EVR 10	38.22	35.36	25.88	53.55	42.54	48.15	42.84
EVR 15	52.3	48.38	35.41	73.28	58.22	65.89	58.62
EVR 20	100.57	93.04	68.1	140.92	111.96	126.72	112.74
EVR 22	120.68	111.65	81.72	—	—	—	—
EVR 25	152.42	141.01	103.21	—	—	—	—
EVR 32	243.83	225.57	165.11	—	—	—	—
EVR 40	380.9	352.39	257.92	—	—	—	—
Suction vapour							
EVR 2	0.35	0.26	0.31	0.57	0.44	0.2	0.24
EVR 3	0.6	0.44	0.52	0.96	0.74	0.34	0.41
EVR 6	1.8	1.3	1.6	2.86	2.18	0.99	1.21
EVR 10	4.3	3.1	3.9	6.79	5.18	2.36	2.86
EVR 15	5.9	4.2	5.3	9.29	7.09	3.23	3.92
EVR 20	11.4	8.1	10.2	17.87	13.64	6.21	7.53
EVR 22	13.7	9.7	12.2	—	—	—	—
EVR 25	22.8	16.3	20.4	—	—	—	—
EVR 32	36.5	26.1	32.6	—	—	—	—
EVR 40	57	40.8	51	—	—	—	—
Hot gas							
EVR 2	1.48	1.17	1.21	2.32	1.64	0.88	0.99
EVR 3	2.49	1.98	2.03	3.91	2.77	1.48	1.68
EVR 6	7.4	5.86	6.02	11.58	8.2	4.39	4.97
EVR 10	17.5	13.9	14.3	27.5	19.48	10.43	11.82
EVR 15	24	19	19.6	37.63	26.66	14.27	16.17
EVR 20	46.2	36.6	37.7	72.37	51.26	27.44	31.09
EVR 22	55.4	43.9	45.2	—	—	—	—
EVR 25	92.3	73.2	75.3	—	—	—	—
EVR 32	148	117	120	—	—	—	—
EVR 40	231	183	188	—	—	—	—

Rated liquid and suction vapour capacity is based on evaporating temperature $t_e = -10\text{ °C}$, liquid temperature ahead of valve $t_l = 25\text{ °C}$, pressure drop in valve $\Delta p = 0.15\text{ bar}$.

Rated hot gas capacity is based on condensing temperature $t_c = 40\text{ °C}$, pressure drop across valve $\Delta p = 0.8\text{ bar}$, hot gas temperature $t_h = 65\text{ °C}$, and subcooling of refrigerant $\Delta t_{sub} = 4\text{ K}$.

Ordering
(continued)

EVR solder connections, Normally Closed (NC) - separate valve bodies

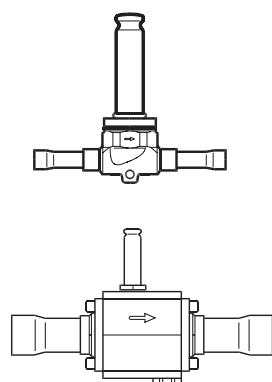

Type	Current type	Connection size [in]	Connection size [mm]	Manual operation	Max. working pressure [bar]	K _v value [m ³ /h]	Code no.
EVR 2	AC	1/4	—	No	45.2	0.16	032F1201
	AC	—	6	No	45.2	0.16	032F1202
EVR 3	AC / DC	1/4	—	No	45.2	0.27	032F1206
	AC / DC	3/8	—	No	45.2	0.27	032F1204
	AC / DC	—	6	No	45.2	0.27	032F1207
	AC / DC	—	10	No	45.2	0.27	032F1208
EVR 6	AC / DC	1/2	—	No	45.2	0.80	032F1209
	AC / DC	3/8	—	No	45.2	0.80	032F1212
	AC / DC	—	10	No	45.2	0.80	032F1213
	AC / DC	—	12	No	45.2	0.80	032F1236
EVR 10	AC / DC	1/2	—	No	35	1.9	032F1217
	AC / DC	—	12	No	35	1.9	032F1218
	AC / DC	5/8	16	No	35	1.9	032F1214
EVR 15	AC / DC	7/8	22	No	32	2.6	032F1225
	AC / DC	—	16	Yes	32	2.6	032F1227
	AC / DC	5/8	16	No	32	2.6	032F1228
EVR 20	AC	7/8	22	No	32	5.0	032F1240
	AC	7/8	—	Yes	32	5.0	032F1254
	AC	1 1/8	—	No	32	5.0	032F1244
	AC	—	28	No	32	5.0	032F1245
	DC	7/8	22	No	32	5.0	032F1264
	DC	7/8	—	Yes	32	5.0	032F1274
EVR 22	AC	1 3/8	35	No	32	6.0	032F3267
EVR 25	AC / DC	1 1/8	—	Yes	32	10.0	032F2200
	AC / DC	1 1/8	—	No	32	10.0	032F2201
	AC / DC	—	28	Yes	32	10.0	032F2205
	AC / DC	—	28	No	32	10.0	032F2206
	AC / DC	1 3/8	—	Yes	32	10.0	032F2207
	AC / DC	1 3/8	—	No	32	10.0	032F2208
EVR 32	AC / DC	1 5/8	—	Yes	32	16.0	042H1103
	AC / DC	1 5/8	—	No	32	16.0	042H1104
	AC / DC	—	35	Yes	32	16.0	042H1105
	AC / DC	—	35	No	32	16.0	042H1106
	AC / DC	—	42	Yes	32	16.0	042H1107
	AC / DC	—	42	No	32	16.0	042H1108
EVR 40	AC / DC	1 5/8	—	Yes	32	25.0	042H1109
	AC / DC	1 5/8	—	No	32	25.0	042H1110
	AC / DC	2 1/8	—	Yes	32	25.0	042H1111
	AC / DC	2 1/8	—	No	32	25.0	042H1112
	AC / DC	—	42	Yes	32	25.0	042H1113
	AC / DC	—	42	No	32	25.0	042H1114

Ordering

(continued)

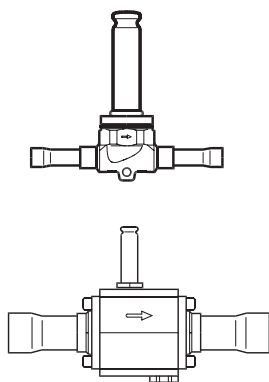

EVR solder connections, Normally Open (NO) - separate valve bodies

Type	Current type	Connection size [in]	Connection size [mm]	Manual operation	Max. Working Pressure [bar]	K _v value [m ³ /h]	Code no.
EVR 6	AC / DC	3/8	—	No	45.2	0.80	032F1290
	AC / DC	—	10	No	45.2	0.80	032F1295
EVR 10	AC / DC	1/2	—	No	35	1.9	032F1291
	AC / DC	—	12	No	35	1.9	032F1296
EVR 15	AC / DC	5/8	16	No	32	2.6	032F1299
	AC / DC	7/8	22	No	32	2.6	032F3270
EVR 20	AC / DC	7/8	22	No	32	5.0	032F1260
	AC / DC	1 1/8	—	No	32	5.0	032F1269
	AC / DC	—	28	No	32	5.0	032F1279
EVR 22	AC	1 3/8	35	No	32	6.0	032F3268

The normal range of coils can be used for the NO valves, with the exception of the double frequency versions of 110 V, 50/60 Hz and 220 V, 50/60 Hz.

Ordering

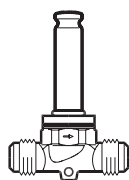

EVR flare connections, Normally Closed (NC) - separate valve bodies

Type	Current type	Connection size [in]	Connection size [mm]	Manual operation	Max. working pressure [bar]	K _v value [m ³ /h]	Code no.
EVR 2	AC	1/4	6	No	45.2	0.16	032F8056
EVR 3	AC / DC	1/4	6	No	45.2	0.27	032F8107
	AC / DC	3/8	10	No	45.2	0.27	032F8116
EVR 6	AC / DC	3/8	10	No	45.2	0.80	032F8072
	AC / DC	1/2	12	No	45.2	0.80	032F8079
EVR 10	AC / DC	1/2	12	No	35	1.9	032F8095
	AC / DC	5/8	16	No	35	1.9	032F8098
EVR 15	AC / DC	5/8	16	No	32	2.6	032F8101
	AC / DC	5/8	16	Yes	32	2.6	032F8100

EVR flare connections, Normally Open (NO) - separate valve bodies

Type	Current type	Connection size [in]	Connection size [mm]	Manual operation	Max. working pressure [bar]	K _v value [m ³ /h]	Code no.
EVR 6	AC / DC	3/8	10	No	45.2	0.80	032F8085
EVR 10	AC / DC	1/2	12	No	35	1.9	032F8090

Valve bodies are supplied without flare nuts.

Separate flare nuts:

- 1/4 in or 6 mm, code no. **011L1101**
- 3/8 in or 10 mm, code no. **011L1135**
- 1/2 in or 12 mm, code no. **011L1103**
- 5/8 in or 16 mm, code no. **011L1167**

See separate data sheet for coils.

The normal range of coils can be used for the NO valves, with the exception of the double frequency versions of 110 V, 50/60 Hz and 220 V, 50/60 Hz.

Ordering
(continued)

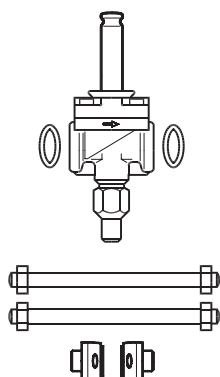

Separate valve bodies, normally closed (NC)

Type	Current type	Connection	Manual operation	Code no. Valve body + gaskets + bolts; without coil and flanges
EVR 15	AC / DC	Flanges	yes	032F1234
	AC / DC	Flanges	no	032F1224
EVR 20	AC	Flanges	yes	032F1253
	AC	Flanges	no	032F1243
	DC	Flanges	yes	032F1273

See separate data sheet for coils.

Flange sets

Type	Connection size		Connection type			Code no.
	[in]	[mm]	Solder [in]	Solder [mm]	Weld [in]	
EVR 15	1/2	—	—	—	yes	027N1115
	5/8	—	yes	—	—	027L1117
	—	16	—	yes	—	027L1116
	3/4	—	—	—	yes	027N1120
	7/8	—	yes	—	—	027L1123
	—	22	—	yes	—	027L1122
EVR 20	3/4	—	—	—	yes	027N1220
	7/8	—	yes	—	—	027L1223
	—	22	—	yes	—	027L1222
	1	—	—	—	yes	027N1225
	1 1/8	—	yes	—	—	027L1229
	—	28	—	yes	—	027L1228

Example

EVR 15 without manual operation,
code no. **032F1224**

+ coil with terminal box, 220 V, 50 Hz,
code no. **018F6701**

1/2 in weld flange set,
code no. **027N1115**

See separate data sheet for coils.

Accessories

Description	Code no.
Strainer FA for direct mounting	See "FA"

**Capacity
Liquid**

Type	Liquid capacity Q_e [kW] at pressure drop across valve Δp [bar]				
	0.1	0.2	0.3	0.4	0.5

R22/R407C

EVR 2	2.6	3.7	4.5	5.2	5.9
EVR 3	4.4	6.3	7.7	8.8	9.9
EVR 6	13.1	18.5	22.7	26.2	29.3
EVR 10	31.1	44.0	53.9	62.2	69.6
EVR 15	42.6	60.2	73.8	85.2	95.2
EVR 20	81.9	115.8	141.9	163.8	183.2
EVR 22	98.3	139.0	170.2	196.6	219.8
EVR 25	163.8	231.7	283.7	327.6	366.3
EVR 32	262.1	370.7	454.0	524.2	586.1
EVR 40	409.5	579.2	709.3	819.1	915.8

R134a

EVR 2	2.4	3.5	4.2	4.9	5.5
EVR 3	4.1	5.8	7.1	8.2	9.2
EVR 6	12.2	17.3	21.1	24.4	27.3
EVR 10	29.0	41.0	50.2	58.0	64.8
EVR 15	39.7	56.1	68.7	79.3	88.7
EVR 20	76.3	107.9	132.1	152.6	170.6
EVR 22	91.5	129.5	158.6	183.1	204.7
EVR 25	152.6	215.8	264.3	305.2	341.2
EVR 32	244.1	345.2	422.8	488.2	545.9
EVR 40	381.4	539.4	660.7	762.9	852.9

Capacities are based on:
 – liquid temperature
 $t_l = 25\text{ °C}$ ahead of valve,
 – evaporating temperature
 $t_e = -10\text{ °C}$, superheat 0 K.

Correction factors

When sizing valves, the plant capacity must be multiplied by a correction factor depending on liquid temperature t_l ahead of valve/evaporator.

When the corrected capacity is known, the selection can be made from the table.

Correction factors based on liquid temperature t_l

t_l [°C]	-10	0	10	15	20	25	30	35	40	45	50
R22/R407C	1.31	1.22	1.13	1.09	1.04	1.00	0.96	0.91	0.86	0.82	0.77
R134a	1.37	1.27	1.16	1.11	1.05	1.00	0.95	0.89	0.84	0.78	0.73

**Capacity
Liquid**
(continued)

Type	Liquid capacity Q_e [kW] at pressure drop across valve Δp [bar]				
	0.1	0.2	0.3	0.4	0.5

R404A/R507

EVR 2	1.8	2.5	3.1	3.6	4.0
EVR 3	3.0	4.3	5.2	6.0	6.7
EVR 6	8.9	12.6	15.5	17.9	20.0
EVR 10	21.2	30.0	36.7	42.4	47.4
EVR 15	29.0	41.0	50.3	58.0	64.9
EVR 20	55.8	78.9	96.7	111.6	124.8
EVR 22	67.0	94.7	116.0	133.9	149.7
EVR 25	111.6	157.8	193.3	223.2	249.6
EVR 32	178.6	252.6	309.3	357.2	399.3
EVR 40	279.0	394.6	483.3	558.1	623.9

R32

EVR 2	3.7	5.2	6.4	7.4	8.2
EVR 3	6.2	8.8	10.8	12.4	13.9
EVR 6	18.4	26.1	31.9	36.8	41.2
EVR 10	43.8	61.9	75.8	87.5	97.8
EVR 15	59.9	84.7	103.7	119.7	133.9
EVR 20	115.1	162.8	199.4	230.3	257.5

Capacities are based on:
 – liquid temperature
 $t_l = 25\text{ °C}$ ahead of valve,
 – evaporating temperature
 $t_e = -10\text{ °C}$, superheat 0 K.

Correction factors

When sizing valves, the plant capacity must be multiplied by a correction factor depending on liquid temperature t_l ahead of valve/evaporator.

When the corrected capacity is known, the selection can be made from the table.

Correction factors based on liquid temperature t_l

t_l [°C]	-10	0	10	15	20	25	30	35	40	45	50
R404A/R507	1.50	1.36	1.22	1.14	1.07	1.00	0.93	0.85	0.78	0.70	0.62
R32	1.31	1.23	1.14	1.09	1.05	1.00	0.95	0.90	0.86	0.81	0.75

**Capacity
Liquid**
(continued)

Type	Liquid capacity Q_e [kW] at pressure drop across valve Δp [bar]				
	0.1	0.2	0.3	0.4	0.5

R290

EVR 2	2.9	4.2	5.1	5.9	6.6
EVR 3	5.0	7.0	8.6	9.9	11.1
EVR 6	14.7	20.8	25.5	29.4	32.9
EVR 10	35.0	49.4	60.6	69.9	78.2
EVR 15	47.8	67.7	82.9	95.7	107.0
EVR 20	92.0	130.1	159.4	184.0	205.7

Capacities are based on:
 – liquid temperature
 $t_l = 25$ °C ahead of valve,
 – evaporating temperature
 $t_e = -10$ °C, superheat 0 K.

Correction factors

When sizing valves, the plant capacity must be multiplied by a correction factor depending on liquid temperature t_l ahead of valve/evaporator.

When the corrected capacity is known, the selection can be made from the table.

Correction factors based on liquid temperature t_l

t_l [°C]	-10	0	10	15	20	25	30	35	40	45	50
R290	1.36	1.26	1.16	1.11	1.05	1.00	0.95	0.89	0.84	0.78	0.73

**Capacity
Liquid**
(continued)

Type	Liquid capacity Q_e [kW] at pressure drop across valve Δp [bar]				
	0.1	0.2	0.3	0.4	0.5

R600

EVR 2	3.3	4.7	5.7	6.6	7.4
EVR 3	5.6	7.9	9.7	11.2	12.5
EVR 6	16.6	23.4	28.7	33.1	37.1
EVR 10	39.4	55.7	68.2	78.7	88.0
EVR 15	53.9	76.2	93.3	107.7	120.4
EVR 20	103.6	146.5	179.4	207.2	231.6
EVR 22	—	—	—	—	—
EVR 25	—	—	—	—	—
EVR 32	—	—	—	—	—
EVR 40	—	—	—	—	—

R600a

EVR 2	2.9	4.2	5.1	5.9	6.6
EVR 3	5.0	7.0	8.6	9.9	11.1
EVR 6	14.7	20.8	25.5	29.4	32.9
EVR 10	34.9	49.4	60.5	69.8	78.1
EVR 15	47.8	67.6	82.8	95.6	106.8
EVR 20	91.9	130.0	159.2	183.8	205.5

Capacities are based on:
 – liquid temperature $t_l = 25\text{ °C}$ ahead of valve,
 – evaporating temperature $t_e = -10\text{ °C}$, superheat 0 K.

Correction factors

When sizing valves, the plant capacity must be multiplied by a correction factor depending on liquid temperature t_l ahead of valve/evaporator.

When the corrected capacity is known, the selection can be made from the table.

Correction factors based on liquid temperature t_l

t_l [°C]	-10	0	10	15	20	25	30	35	40	45	50
R600	1.31	1.22	1.13	1.09	1.04	1.00	0.96	0.91	0.87	0.82	0.77
R600a	1.34	1.25	1.15	1.10	1.05	1.00	0.95	0.90	0.85	0.80	0.75

**Capacity
Suction**

Type	Pressure drop Δp [bar]	Suction vapour capacity Q_e [kW] at evaporating temperature t_e [°C]					
		-40	-30	-20	-10	0	10

R22/R407C

EVR 2	0.1	0.15	0.19	0.24	0.29	0.35	0.42
	0.15	0.17	0.23	0.29	0.35	0.43	0.51
	0.2	0.19	0.26	0.33	0.41	0.49	0.59
EVR 3	0.1	0.25	0.32	0.40	0.49	0.60	0.71
	0.15	0.29	0.38	0.48	0.60	0.73	0.87
	0.2	0.32	0.43	0.55	0.69	0.83	1.00
EVR 6	0.10	0.73	0.94	1.19	1.46	1.77	2.11
	0.15	0.86	1.13	1.44	1.77	2.15	2.57
	0.20	0.96	1.28	1.64	2.03	2.47	2.96
EVR 10	0.10	1.73	2.24	2.82	3.47	4.20	5.01
	0.15	2.05	2.69	3.41	4.21	5.11	6.11
	0.20	2.29	3.04	3.88	4.82	5.87	7.02
EVR 15	0.10	2.37	3.07	3.86	4.75	5.75	6.85
	0.15	2.81	3.68	4.66	5.77	6.99	8.36
	0.20	3.13	4.16	5.32	6.60	8.03	9.61
EVR 20	0.10	4.55	5.90	7.42	9.13	11.05	13.18
	0.15	5.40	7.08	8.97	11.09	13.45	16.07
	0.20	6.02	8.01	10.22	12.69	15.44	18.48
EVR 22	0.10	5.46	7.08	8.90	10.96	13.26	15.81
	0.15	6.47	8.49	10.76	13.31	16.14	19.28
	0.20	7.22	9.61	12.27	15.23	18.53	22.17
EVR 25	0.10	9.11	11.79	14.84	18.27	22.10	26.35
	0.15	10.79	14.16	17.94	22.18	26.90	32.14
	0.20	12.03	16.01	20.45	25.39	30.88	36.95
EVR 32	0.10	14.57	18.87	23.74	29.23	35.36	42.17
	0.15	17.26	22.65	28.71	35.49	43.05	51.42
	0.20	19.25	25.62	32.71	40.62	49.40	59.12
EVR 40	0.10	22.76	29.48	37.10	45.67	55.25	65.88
	0.15	26.98	35.39	44.85	55.45	67.26	80.35
	0.20	30.08	40.03	51.11	63.47	77.19	92.38

Capacities are based on liquid temperature $t_l = 25$ °C ahead of evaporator.

The table values refer to the evaporator capacity and are given as a function of evaporating temperature t_e and pressure drop Δp across valve.

Capacities are based on dry, saturated vapour ahead of valve.

During operation with superheated vapour ahead of valve, the capacities are reduced by 4% for each 10 K superheat.

Correction factors

When sizing valves, the evaporator capacity must be multiplied by a correction factor depending on liquid temperature t_l ahead of expansion valve.

When the corrected capacity is known, the selection can be made from the table.

Correction factors for evaporating temperature t_e

t_l [°C]	-40	-30	-20	-10	0	10	15
R22/R407C	0.52	0.66	0.82	1.00	1.20	1.43	1.56

Capacity Suction
(continued)

Type	Pressure drop Δp [bar]	Suction vapour capacity Q_e [kW] at evaporating temperature t_e [°C]					
		-40	-30	-20	-10	0	10

R134a

EVR 2	0.1	0.09	0.13	0.17	0.22	0.27	0.33
	0.15	0.10	0.15	0.20	0.26	0.33	0.41
	0.2	0.10	0.16	0.22	0.29	0.37	0.47
EVR 3	0.1	0.15	0.21	0.28	0.36	0.46	0.56
	0.15	0.17	0.25	0.34	0.44	0.55	0.69
	0.2	0.18	0.27	0.38	0.50	0.63	0.78
EVR 6	0.1	0.45	0.63	0.84	1.08	1.35	1.67
	0.15	0.50	0.73	1.00	1.30	1.64	2.03
	0.2	0.52	0.81	1.12	1.47	1.87	2.33
EVR 10	0.1	1.06	1.49	1.99	2.56	3.22	3.97
	0.15	1.19	1.74	2.37	3.08	3.89	4.82
	0.2	1.25	1.92	2.66	3.49	4.44	5.52
EVR 15	0.1	1.45	2.04	2.72	3.50	4.40	5.43
	0.15	1.63	2.39	3.24	4.21	5.33	6.60
	0.2	1.71	2.62	3.64	4.78	6.08	7.56
EVR 20	0.1	2.79	3.92	5.23	6.73	8.46	10.44
	0.15	3.14	4.59	6.23	8.10	10.25	12.69
	0.2	3.28	5.04	6.99	9.19	11.70	14.53
EVR 22	0.1	3.35	4.71	6.27	8.08	10.16	12.53
	0.15	3.77	5.50	7.47	9.73	12.30	15.22
	0.2	3.94	6.05	8.39	11.03	14.04	17.44
EVR 25	0.1	5.59	7.84	10.45	13.46	16.93	20.88
	0.15	6.28	9.17	12.46	16.21	20.50	25.37
	0.2	6.56	10.08	13.98	18.39	23.39	29.07
EVR 32	0.1	8.94	12.55	16.72	21.54	27.08	33.41
	0.15	10.05	14.68	19.93	25.93	32.79	40.60
	0.2	10.50	16.13	22.37	29.42	37.43	46.51
EVR 40	0.1	13.97	19.61	26.13	33.66	42.32	52.20
	0.15	15.70	22.94	31.14	40.52	51.24	63.44
	0.2	16.40	25.21	34.95	45.97	58.49	72.67

Capacities are based on liquid temperature $t_l = 25$ °C ahead of evaporator.

The table values refer to the evaporator capacity and are given as a function of evaporating temperature t_e and pressure drop Δp across valve.

Capacities are based on dry, saturated vapour ahead of valve.

During operation with superheated vapour ahead of valve, the capacities are reduced by 4% for each 10 K superheat.

Correction factors

When sizing valves, the evaporator capacity must be multiplied by a correction factor depending on liquid temperature t_l ahead of expansion valve.

When the corrected capacity is known, the selection can be made from the table.

Correction factors based on evaporating temperature t_e

t_l [°C]	-40	-30	-20	-10	0	10	15
R134a	0.45	0.61	0.79	1.00	1.25	1.53	1.69

Capacity Suction
(continued)

Type	Pressure drop Δp [bar]	Suction vapour capacity Q_e [kW] at evaporating temperature t_e [°C]					
		-40	-30	-20	-10	0	10

R404A/R507

EVR 2	0.1	0.12	0.16	0.20	0.25	0.31	0.38
	0.15	0.14	0.19	0.25	0.31	0.38	0.47
	0.2	0.16	0.22	0.28	0.36	0.44	0.54
EVR 3	0.1	0.20	0.27	0.34	0.43	0.53	0.65
	0.15	0.24	0.32	0.41	0.52	0.65	0.79
	0.2	0.27	0.36	0.47	0.60	0.74	0.91
EVR 6	0.1	0.60	0.79	1.01	1.27	1.57	1.91
	0.15	0.71	0.95	1.23	1.55	1.92	2.33
	0.2	0.80	1.08	1.40	1.78	2.20	2.68
EVR 10	0.1	1.42	1.88	2.41	3.03	3.73	4.54
	0.15	1.69	2.26	2.92	3.68	4.55	5.54
	0.2	1.90	2.57	3.33	4.22	5.23	6.37
EVR 15	0.1	1.94	2.57	3.30	4.14	5.11	6.21
	0.15	2.32	3.09	4.00	5.03	6.23	7.58
	0.2	2.60	3.51	4.56	5.77	7.15	8.72
EVR 20	0.1	3.74	4.94	6.34	7.96	9.83	11.95
	0.15	4.46	5.95	7.68	9.68	11.97	14.58
	0.2	5.00	6.75	8.77	11.10	13.75	16.77
EVR 22	0.1	4.49	5.93	7.61	9.56	11.79	14.34
	0.15	5.35	7.14	9.22	11.62	14.37	17.49
	0.2	6.00	8.10	10.53	13.32	16.50	20.12
EVR 25	0.1	7.48	9.88	12.68	15.93	19.65	23.89
	0.15	8.91	11.90	15.37	19.36	23.94	29.15
	0.2	10.00	13.50	17.55	22.19	27.50	33.54
EVR 32	0.1	11.97	15.81	20.29	25.49	31.44	38.23
	0.15	14.26	19.04	24.59	30.98	38.31	46.65
	0.2	16.00	21.61	28.07	35.51	44.01	53.67
EVR 40	0.1	18.70	24.70	31.71	39.82	49.13	59.73
	0.15	22.28	29.75	38.41	48.41	59.86	72.89
	0.2	25.01	33.76	43.86	55.48	68.76	83.85

Capacities are based on liquid temperature $t_l = 25$ °C ahead of evaporator.

The table values refer to the evaporator capacity and are given as a function of evaporating temperature t_e and pressure drop Δp across valve.

Capacities are based on dry, saturated vapour ahead of valve.

During operation with superheated vapour ahead of valve, the capacities are reduced by 4% for each 10 K superheat.

Correction factors

When sizing valves, the evaporator capacity must be multiplied by a correction factor depending on liquid temperature t_l ahead of expansion valve.

Correction factors based on evaporating temperature t_e

When the corrected capacity is known, the selection can be made from the table.

t_l [°C]	-40	-30	-20	-10	0	10	15
R404A/R507	0.48	0.63	0.80	1.00	1.23	1.49	1.63

Capacity Suction
(continued)

Type	Pressure drop Δp [bar]	Suction vapour capacity Q_e [kW] at evaporating temperature t_e [°C]					
		-40	-30	-20	-10	0	10

R32

EVR 2	0.1	0.25	0.31	0.39	0.47	0.56	0.66
	0.15	0.30	0.38	0.47	0.57	0.68	0.81
	0.2	0.34	0.43	0.54	0.66	0.79	0.93
EVR 3	0.1	0.42	0.53	0.65	0.79	0.94	1.11
	0.15	0.50	0.64	0.79	0.96	1.15	1.36
	0.2	0.57	0.73	0.91	1.11	1.33	1.57
EVR 6	0.1	1.24	1.57	1.94	2.35	2.80	3.30
	0.15	1.49	1.90	2.35	2.86	3.42	4.03
	0.2	1.70	2.17	2.70	3.29	3.93	4.64
EVR 10	0.1	2.95	3.72	4.60	5.57	6.65	7.83
	0.15	3.55	4.51	5.59	6.79	8.11	9.57
	0.2	4.03	5.16	6.41	7.80	9.34	11.02
EVR 15	0.1	4.03	5.10	6.29	7.62	9.09	10.71
	0.15	4.86	6.18	7.65	9.29	11.10	13.09
	0.2	5.51	7.05	8.77	10.68	12.78	15.08
EVR 20	0.1	7.76	9.80	12.10	14.66	17.49	20.60
	0.15	9.34	11.88	14.71	17.87	21.35	25.17
	0.2	10.60	13.57	16.87	20.54	24.57	29.00

Capacities are based on liquid temperature $t_l = 25$ °C ahead of evaporator.

The table values refer to the evaporator capacity and are given as a function of evaporating temperature t_e and pressure drop Δp across valve.

Capacities are based on dry, saturated vapour ahead of valve.

During operation with superheated vapour ahead of valve, the capacities are reduced by 4% for each 10 K superheat.

Correction factors

When sizing valves, the evaporator capacity must be multiplied by a correction factor depending on liquid temperature t_l ahead of expansion valve.

When the corrected capacity is known, the selection can be made from the table.

Correction factors based on evaporating temperature t_e

t_l [°C]	-40	-30	-20	-10	0	10	15
R32	0.54	0.67	0.83	1.00	1.19	1.40	1.51

Capacity Suction
(continued)

Type	Pressure drop Δp [bar]	Suction vapour capacity Q_e [kW] at evaporating temperature t_e [°C]					
		-40	-30	-20	-10	0	10

R290

EVR 2	0.1	0.18	0.23	0.29	0.36	0.44	0.52
	0.15	0.21	0.28	0.35	0.44	0.53	0.64
	0.2	0.24	0.31	0.40	0.50	0.61	0.73
EVR 3	0.1	0.30	0.39	0.49	0.61	0.74	0.88
	0.15	0.36	0.47	0.59	0.74	0.90	1.08
	0.2	0.40	0.53	0.68	0.84	1.03	1.24
EVR 6	0.89	0.89	1.16	1.46	1.80	2.19	2.62
	1.06	1.06	1.39	1.76	2.18	2.66	3.19
	1.18	1.18	1.57	2.01	2.50	3.05	3.67
EVR 10	2.12	2.12	2.75	3.46	4.27	5.19	6.22
	2.52	2.52	3.30	4.18	5.18	6.31	7.58
	2.81	2.81	3.73	4.76	5.93	7.24	8.71
EVR 15	2.91	2.91	3.76	4.74	5.85	7.10	8.51
	3.45	3.45	4.51	5.72	7.09	8.64	10.37
	3.85	3.85	5.10	6.52	8.11	9.91	11.92
EVR 20	5.59	5.59	7.23	9.11	11.24	13.66	16.37
	6.63	6.63	8.68	11.01	13.64	16.62	19.95
	7.39	7.39	9.81	12.53	15.60	19.06	22.92

Capacities are based on liquid temperature $t_l = 25$ °C ahead of evaporator.

The table values refer to the evaporator capacity and are given as a function of evaporating temperature t_e and pressure drop Δp across valve.

Capacities are based on dry, saturated vapour ahead of valve.

During operation with superheated vapour ahead of valve, the capacities are reduced by 4% for each 10 K superheat.

Correction factors

When sizing valves, the evaporator capacity must be multiplied by a correction factor depending on liquid temperature t_l ahead of expansion valve.

When the corrected capacity is known, the selection can be made from the table.

Correction factors based on evaporating temperature t_e

t_l [°C]	-40	-30	-20	-10	0	10	15
R290	0.51	0.65	0.82	1.00	1.21	1.44	1.57

Capacity Suction
(continued)

Type	Pressure drop Δp [bar]	Suction vapour capacity Q_e [kW] at evaporating temperature t_e [°C]					
		-40	-30	-20	-10	0	10

R600

EVR 2	0.1	—	0.08	0.13	0.17	0.22	0.28
	0.15	—	—	0.14	0.20	0.26	0.34
	0.2	—	—	—	0.21	0.29	0.38
EVR 3	0.1	—	0.14	0.21	0.29	0.38	0.48
	0.15	—	—	0.23	0.34	0.45	0.57
	0.2	—	—	—	0.36	0.50	0.64
EVR 6	0.89	—	0.42	0.63	0.86	1.12	1.42
	1.06	—	—	0.70	0.99	1.32	1.70
	1.18	—	—	—	1.07	1.47	1.91
EVR 10	2.12	—	1.01	1.50	2.05	2.67	3.37
	2.52	—	—	1.65	2.36	3.15	4.03
	2.81	—	—	—	2.55	3.49	4.53
EVR 15	2.91	—	1.38	2.05	2.80	3.65	4.61
	3.45	—	—	2.26	3.23	4.30	5.51
	3.85	—	—	—	3.49	4.78	6.20
EVR 20	5.59	—	2.65	3.94	5.38	7.01	8.87
	6.63	—	—	4.35	6.21	8.28	10.60
	7.39	—	—	—	6.72	9.19	11.93

Capacities are based on liquid temperature $t_l = 25$ °C ahead of evaporator.

The table values refer to the evaporator capacity and are given as a function of evaporating temperature t_e and pressure drop Δp across valve.

Capacities are based on dry, saturated vapour ahead of valve.

During operation with superheated vapour ahead of valve, the capacities are reduced by 4% for each 10 K superheat.

Correction factors

When sizing valves, the evaporator capacity must be multiplied by a correction factor depending on liquid temperature t_l ahead of expansion valve.

When the corrected capacity is known, the selection can be made from the table.

Correction factors based on evaporating temperature t_e

t_l [°C]	-40	-30	-20	-10	0	10	15
R600	0.42	0.58	0.77	1.00	1.27	1.57	1.74

Capacity Suction
(continued)

Type	Pressure drop Δp [bar]	Suction vapour capacity Q_e [kW] at evaporating temperature t_e [°C]					
		-40	-30	-20	-10	0	10

R600a

EVR 2	0.1	0.08	0.11	0.16	0.20	0.26	0.32
	0.15	—	0.13	0.18	0.24	0.31	0.39
	0.2	—	—	0.20	0.27	0.35	0.44
EVR 3	0.1	0.13	0.19	0.26	0.34	0.44	0.54
	0.15	—	0.21	0.30	0.41	0.52	0.66
	0.2	—	—	0.33	0.45	0.59	0.74
EVR 6	0.89	0.38	0.57	0.78	1.02	1.30	1.61
	1.06	—	0.63	0.90	1.21	1.55	1.94
	1.18	—	—	0.98	1.34	1.75	2.21
EVR 10	2.12	0.90	1.34	1.85	2.42	3.08	3.83
	2.52	—	1.49	2.14	2.86	3.68	4.61
	2.81	—	—	2.32	3.19	4.15	5.24
EVR 15	2.91	1.23	1.84	2.53	3.31	4.21	5.24
	3.45	—	2.04	2.92	3.92	5.04	6.31
	3.85	—	—	3.17	4.36	5.68	7.17
EVR 20	5.59	2.36	3.53	4.86	6.37	8.10	10.07
	6.63	—	3.92	5.62	7.53	9.69	12.14
	7.39	—	—	6.10	8.38	10.93	13.79

Capacities are based on liquid temperature $t_l = 25$ °C ahead of evaporator.

The table values refer to the evaporator capacity and are given as a function of evaporating temperature t_e and pressure drop Δp across valve.

Capacities are based on dry, saturated vapour ahead of valve.

During operation with superheated vapour ahead of valve, the capacities are reduced by 4% for each 10 K superheat.

Correction factors

When sizing valves, the evaporator capacity must be multiplied by a correction factor depending on liquid temperature t_l ahead of expansion valve.

When the corrected capacity is known, the selection can be made from the table.

Correction factors based on evaporating temperature t_e

t_l [°C]	-40	-30	-20	-10	0	10	15
R600a	0.45	0.60	0.78	1.00	1.25	1.54	1.70

Capacity Suction
(continued)

Hot gas defrosting

With hot gas defrosting it is not normally possible to select a valve from condensing temperature t_c and evaporating temperature t_e .

This is because the pressure in the evaporator as a rule quickly rises to a value near that of the condensing pressure. It remains at this value until the defrosting is finished.

In most cases therefore, the valve will be selected from condensing temperature t_c and pressure drop Δp across the valve, as shown in the example for heat recovery.

Heat recovery

The following is given:

- Refrigerant = R22/R407C
- Evaporating temperature $t_e = -30\text{ °C}$
- Condensing temperature $t_c = 40\text{ °C}$
- Hot gas temperature ahead of valve $t_h = 85\text{ °C}$
- Heat recovery condenser yield $Q_h = 8\text{ kW}$

The capacity table for R22/R407C with $t_c = 40\text{ °C}$ gives the capacity for an EVR 10 as 8.9 kW, when pressure drop Δp is 0.2 bar.

The required capacity is calculated as :

$$Q_{table} = f_{evaporator} \times f_{hot_temperature} \times Q_h$$

The correction factor for $t_e = -30\text{ °C}$ is given in the table as 0.95.

The correction for hot gas temperature $t_h = 85\text{ °C}$ has been calculated as 4% which corresponds to a factor of 1.04.

Q_h must be corrected with factors found:

With $\Delta p = 0.2\text{ bar}$
is $Q_h = 8.71 \times 0.95 \times 1.04 = 8.6\text{ kW}$.

With $\Delta p = 0.1\text{ bar}$, Q_h becomes only
 $6.19 \times 0.95 \times 1.04 = 6.1\text{ kW}$.

An EVR 6 would also be able to give the required capacity, but with Δp at approx. 1 bar. The EVR 6 is therefore too small.

The EVR 15 is so large that it is doubtful whether the necessary Δp of approx. 0.1 bar could be obtained.

An EVR 15 would therefore be too large.

Result: An EVR 10 is the correct valve for the given conditions.

**Capacity
Hot gas**

Type	Pressure drop across valve Δp [bar]	Hot gas capacity Qh [kW] Evaporating temp. $t_e = -10$ °C. Hot gas temp. $t_h = t_c$ 25 °C. Subcooling $\Delta t_{sub} = 4$ K				
		Condensing temperature t_c [°C]				
		20	30	40	50	60

R22/R407C

EVR 2	0.1	0.47	0.50	0.52	0.54	0.55
	0.2	0.65	0.70	0.73	0.76	0.77
	0.4	0.91	0.98	1.03	1.07	1.08
	0.8	1.25	1.35	1.43	1.49	1.51
	1.6	1.65	1.81	1.95	2.04	2.09
EVR 3	0.1	0.79	0.84	0.88	0.91	0.92
	0.2	1.10	1.18	1.24	1.28	1.30
	0.4	1.54	1.65	1.74	1.80	1.83
	0.8	2.11	2.27	2.41	2.51	2.56
	1.6	2.78	3.06	3.28	3.44	3.53
EVR 6	0.1	2.33	2.48	2.61	2.69	2.73
	0.2	3.27	3.49	3.67	3.79	3.85
	0.4	4.55	4.88	5.14	5.33	5.42
	0.8	6.24	6.74	7.14	7.43	7.57
	1.6	8.24	9.07	9.73	10.20	10.47
EVR 10	0.1	5.53	5.89	6.19	6.39	6.48
	0.2	7.76	8.29	8.71	9.01	9.14
	0.4	10.81	11.59	12.21	12.65	12.86
	0.8	14.82	16.01	16.96	17.64	17.99
	1.6	19.58	21.53	23.10	24.24	24.86
EVR 15	0.1	7.57	8.07	8.47	8.75	8.87
	0.2	10.62	11.34	11.92	12.33	12.51
	0.4	14.80	15.86	16.71	17.32	17.60
	0.8	20.28	21.90	23.21	24.15	24.61
	1.6	26.79	29.47	31.61	33.16	34.02

An increase in hot gas temperature t_h of 10 K, based on $t_h = t_c + 25$ °C, reduces valve capacity approx. 2% and vice versa.

A change in evaporating temperature t_e changes valve capacity; see correction factor table below.

Correction factors

When sizing valves, the table value must be multiplied by a correction factor depending on evaporating temperature t_e .

Correction factors for evaporating temperature t_e

t_e [°C]	-40	-30	-20	-10	0	10	15
R22/R407C	0.92	0.95	0.98	1.00	1.02	1.04	1.05

**Capacity
Hot gas**
(continued)

Type	Pressure drop across valve Δp [bar]	Hot gas capacity Qh [kW] Evaporating temp. $t_e = -10^\circ\text{C}$. Hot gas temp. $t_h = t_c = 25^\circ\text{C}$. Subcooling $\Delta t_{\text{sub}} = 4\text{ K}$				
		Condensing temperature t_c [°C]				
		20	30	40	50	60

R22/R407C (continued)

EVR 20	0.1	14.55	15.51	16.28	16.82	17.06
	0.2	20.43	21.81	22.93	23.71	24.07
	0.4	28.45	30.50	32.14	33.30	33.85
	0.8	38.99	42.12	44.64	46.43	47.33
	1.6	51.52	56.67	60.79	63.78	65.42
EVR 22	0.1	17.46	18.61	19.54	20.19	20.48
	0.2	24.51	26.17	27.51	28.45	28.88
	0.4	34.15	36.59	38.57	39.96	40.62
	0.8	46.79	50.55	53.57	55.72	56.80
	1.6	61.82	68.00	72.95	76.53	78.50
EVR 25	0.1	29.10	31.02	32.57	33.65	34.13
	0.2	40.86	43.62	45.86	47.42	48.13
	0.4	56.91	60.99	64.28	66.60	67.69
	0.8	77.99	84.24	89.28	92.87	94.67
	1.6	103.03	113.33	121.58	127.56	130.84
EVR 32	0.1	46.57	49.64	52.11	53.83	54.60
	0.2	65.37	69.80	73.37	75.87	77.01
	0.4	91.05	97.59	102.85	106.56	108.31
	0.8	124.78	134.79	142.85	148.59	151.47
	1.6	164.86	181.33	194.53	204.09	209.34
EVR 40	0.1	72.76	77.55	81.42	84.12	85.32
	0.2	102.14	109.06	114.64	118.55	120.33
	0.4	142.27	152.48	160.70	166.50	169.23
	0.8	194.97	210.61	223.20	232.17	236.67
	1.6	257.59	283.33	303.96	318.89	327.09

An increase in hot gas temperature t_h of 10 K, based on $t_h = t_c = 25^\circ\text{C}$, reduces valve capacity approx. 2% and vice versa.

A change in evaporating temperature t_e changes valve capacity; see correction factor table below.

Correction factors

When sizing valves, the table value must be multiplied by a correction factor depending on evaporating temperature t_e .

Correction factors for evaporating temperature t_e

t_e [°C]	-40	-30	-20	-10	0	10	15
R22/R407C	0.92	0.95	0.98	1.00	1.02	1.04	1.05

**Capacity
Hot gas**
(continued)

Type	Pressure drop across valve Δp [bar]	Hot gas capacity Qh [kW] Evaporating temp. $t_e = -10$ °C. Hot gas temp. $t_h = t_c = 25$ °C. Subcooling $\Delta t_{sub} = 4$ K				
		Condensing temperature t_c [°C]				
		20	30	40	50	60

R134a

EVR 2	0.1	0.37	0.39	0.41	0.42	0.42
	0.2	0.52	0.55	0.58	0.59	0.59
	0.4	0.71	0.77	0.81	0.83	0.83
	0.8	0.95	1.04	1.11	1.15	1.15
	1.6	1.19	1.35	1.47	1.55	1.57
EVR 3	0.1	0.63	0.67	0.70	0.71	0.71
	0.2	0.87	0.93	0.98	1.00	1.00
	0.4	1.20	1.29	1.36	1.40	1.40
	0.8	1.61	1.76	1.87	1.93	1.94
	1.6	2.01	2.28	2.48	2.61	2.65
EVR 6	0.1	1.85	1.97	2.06	2.10	2.10
	0.2	2.59	2.76	2.89	2.96	2.95
	0.4	3.57	3.84	4.03	4.14	4.14
	0.8	4.77	5.21	5.54	5.73	5.76
	1.6	5.95	6.76	7.35	7.73	7.85
EVR 10	0.1	4.40	4.69	4.89	5.00	4.98
	0.2	6.15	6.57	6.87	7.03	7.01
	0.4	8.47	9.11	9.58	9.83	9.83
	0.8	11.34	12.38	13.15	13.60	13.67
	1.6	14.13	16.05	17.47	18.35	18.65
EVR 15	0.1	6.02	6.41	6.69	6.84	6.81
	0.2	8.41	8.98	9.40	9.62	9.60
	0.4	11.59	12.47	13.11	13.46	13.46
	0.8	15.51	16.95	18.00	18.61	18.71
	1.6	19.34	21.97	23.90	25.12	25.52

An increase in hot gas temperature t_h of 10 K, based on $t_h = t_c = 25$ °C, reduces valve capacity approx. 2% and vice versa.

A change in evaporating temperature t_e changes valve capacity; see correction factor table below.

Correction factors

When sizing valves, the table value must be multiplied by a correction factor depending on evaporating temperature t_e .

Correction factors for evaporating temperature t_e

t_e [°C]	-40	-30	-20	-10	0	10	15
R134a	0.88	0.92	0.96	1.00	1.04	1.08	1.09

**Capacity
Hot gas**
(continued)

Type	Pressure drop across valve Δp [bar]	Hot gas capacity Qh [kW] Evaporating temp. $t_e = -10^\circ\text{C}$. Hot gas temp. $t_h = t_c = 25^\circ\text{C}$. Subcooling $\Delta t_{\text{sub}} = 4\text{ K}$				
		Condensing temperature t_c [$^\circ\text{C}$]				
		20	30	40	50	60

R134a (continued)

EVR 20	0.1	11.58	12.33	12.87	13.15	13.10
	0.2	16.17	17.28	18.08	18.50	18.45
	0.4	22.29	23.98	25.20	25.88	25.88
	0.8	29.83	32.59	34.61	35.79	35.97
	1.6	37.19	42.25	45.97	48.30	49.08
EVR 22	0.1	13.90	14.80	15.45	15.78	15.73
	0.2	19.41	20.73	21.69	22.20	22.15
	0.4	26.74	28.77	30.25	31.06	31.06
	0.8	35.80	39.11	41.54	42.95	43.17
	1.6	44.63	50.70	55.16	57.96	58.89
EVR 25	0.1	23.16	24.66	25.74	26.30	26.21
	0.2	32.35	34.56	36.15	37.00	36.91
	0.4	44.57	47.95	50.41	51.76	51.76
	0.8	59.66	65.18	69.23	71.59	71.95
	1.6	74.38	84.50	91.94	96.60	98.16
EVR 32	0.1	37.06	39.46	41.19	42.09	41.93
	0.2	51.75	55.29	57.85	59.20	59.06
	0.4	71.32	76.73	80.66	82.82	82.81
	0.8	95.45	104.29	110.77	114.54	115.11
	1.6	119.01	135.20	147.10	154.55	157.05
EVR 40	0.1	57.91	61.66	64.36	65.76	65.52
	0.2	80.87	86.39	90.39	92.50	92.27
	0.4	111.44	119.88	126.02	129.40	129.40
	0.8	149.15	162.96	173.07	178.97	179.87
	1.6	185.95	211.24	229.84	241.49	245.39

An increase in hot gas temperature t_h of 10 K, based on $t_h = t_c = 25^\circ\text{C}$, reduces valve capacity approx. 2% and vice versa.

A change in evaporating temperature t_e changes valve capacity; see correction factor table below.

Correction factors

When sizing valves, the table value must be multiplied by a correction factor depending on evaporating temperature t_e .

Correction factors for evaporating temperature t_e

t_e [$^\circ\text{C}$]	-40	-30	-20	-10	0	10	15
R134a	0.88	0.92	0.96	1.00	1.04	1.08	1.09

**Capacity
Hot gas**
(continued)

Type	Pressure drop across valve Δp bar	Hot gas capacity Qh [kW] Evaporating temp. $t_e = -10$ °C. Hot gas temp. $t_h = t_c = 25$ °C. Subcooling $\Delta t_{sub} = 4$ K				
		Condensing temperature t_c [°C]				
		20	30	40	50	60

R404A/R507

EVR 2	0.1	0.42	0.43	0.43	0.41	0.37
	0.2	0.59	0.61	0.60	0.58	0.52
	0.4	0.83	0.85	0.85	0.81	0.73
	0.8	1.14	1.18	1.18	1.14	1.03
	1.6	1.52	1.60	1.62	1.57	1.42
EVR 3	0.1	0.71	0.73	0.72	0.69	0.62
	0.2	1.00	1.02	1.02	0.98	0.88
	0.4	1.40	1.44	1.43	1.37	1.24
	0.8	1.93	1.99	1.99	1.92	1.73
	1.6	2.57	2.69	2.73	2.64	2.40
EVR 6	0.1	2.11	2.16	2.14	2.05	1.84
	0.2	2.97	3.04	3.02	2.89	2.60
	0.4	4.14	4.25	4.24	4.06	3.66
	0.8	5.71	5.89	5.90	5.68	5.13
	1.6	7.62	7.99	8.08	7.83	7.11
EVR 10	0.1	5.02	5.12	5.09	4.87	4.38
	0.2	7.05	7.21	7.17	6.87	6.18
	0.4	9.84	10.10	10.07	9.65	8.70
	0.8	13.55	13.99	14.01	13.48	12.18
	1.6	18.10	18.96	19.18	18.59	16.89
EVR 15	0.1	6.87	7.01	6.97	6.67	6.00
	0.2	9.65	9.87	9.82	9.40	8.46
	0.4	13.47	13.82	13.77	13.21	11.90
	0.8	18.54	19.15	19.18	18.45	16.67
	1.6	24.76	25.95	26.25	25.44	23.11

An increase in hot gas temperature t_h of 10 K, based on $t_h = t_c = 25$ °C, reduces valve capacity approx. 2% and vice versa.

A change in evaporating temperature t_e changes valve capacity; see correction factor table below.

Correction factors

When sizing valves, the table value must be multiplied by a correction factor depending on evaporating temperature t_e .

Correction factors for evaporating temperature t_e

t_e [°C]	-40	-30	-20	-10	0	10	15
R404A/R507	0.86	0.91	0.96	1.00	1.04	1.08	1.10

**Capacity
Hot gas**
(continued)

Type	Pressure drop across valve Δp bar	Hot gas capacity Qh [kW] Evaporating temp. $t_e = -10^\circ\text{C}$. Hot gas temp. $t_h = t_c = 25^\circ\text{C}$. Subcooling $\Delta t_{\text{sub}} = 4\text{ K}$				
		Condensing temperature t_c [$^\circ\text{C}$]				
		20	30	40	50	60

R404A/R507 (continued)

EVR 20	0.1	13.21	13.49	13.40	12.82	11.53
	0.2	18.56	18.98	18.88	18.07	16.27
	0.4	25.90	26.58	26.49	25.40	22.89
	0.8	35.66	36.83	36.88	35.49	32.06
	1.6	47.62	49.91	50.48	48.93	44.44
EVR 22	0.1	15.85	16.18	16.08	15.38	13.84
	0.2	22.27	22.78	22.65	21.69	19.52
	0.4	31.08	31.89	31.79	30.48	27.47
	0.8	42.79	44.19	44.25	42.58	38.47
	1.6	57.15	59.89	60.58	58.72	53.33
EVR 25	0.1	26.41	26.97	26.80	25.64	23.06
	0.2	37.11	37.96	37.75	36.14	32.53
	0.4	51.80	53.15	52.98	50.81	45.79
	0.8	71.32	73.66	73.76	70.97	64.12
	1.6	95.24	99.81	100.97	97.86	88.89
EVR 32	0.1	42.26	43.16	42.87	41.02	36.90
	0.2	59.38	60.74	60.40	57.83	52.05
	0.4	82.89	85.04	84.77	81.29	73.26
	0.8	114.11	117.85	118.01	113.56	102.60
	1.6	152.39	159.70	161.55	156.58	142.22
EVR 40	0.1	66.03	67.43	66.99	64.09	57.65
	0.2	92.78	94.90	94.38	90.36	81.33
	0.4	129.51	132.88	132.45	127.02	114.47
	0.8	178.29	184.14	184.39	177.43	160.31
	1.6	238.11	249.53	252.42	244.65	222.22

An increase in hot gas temperature t_h of 10 K, based on $t_h = t_c = 25^\circ\text{C}$, reduces valve capacity approx. 2% and vice versa.

A change in evaporating temperature t_e changes valve capacity; see correction factor table below.

Correction factors

When sizing valves, the table value must be multiplied by a correction factor depending on evaporating temperature t_e .

Correction factors for evaporating temperature t_e

t_e [$^\circ\text{C}$]	-40	-30	-20	-10	0	10	15
R404A/R507	0.86	0.91	0.96	1.00	1.04	1.08	1.10

**Capacity
Hot gas**
(continued)

Type	Pressure drop across valve Δp bar	Hot gas capacity Qh [kW] Evaporating temp. $t_e = -10$ °C. Hot gas temp. $t_h = t_c = 25$ °C. Subcooling $\Delta t_{sub} = 4$ K				
		Condensing temperature t_c [°C]				
		20	30	40	50	60

R32

EVR 2	0.1	0.74	0.79	0.83	0.87	0.88
	0.2	1.04	1.11	1.18	1.22	1.24
	0.4	1.46	1.56	1.66	1.72	1.75
	0.8	2.02	2.18	2.32	2.41	2.46
	1.6	2.75	3.00	3.20	3.36	3.43
EVR 3	0.1	1.25	1.33	1.41	1.46	1.48
	0.2	1.75	1.88	1.99	2.06	2.09
	0.4	2.46	2.64	2.79	2.90	2.95
	0.8	3.41	3.68	3.91	4.07	4.15
	1.6	4.64	5.06	5.41	5.66	5.79
EVR 6	0.1	3.69	3.95	4.17	4.33	4.39
	0.2	5.19	5.57	5.88	6.11	6.21
	0.4	7.28	7.82	8.28	8.60	8.75
	0.8	10.11	10.91	11.58	12.07	12.29
	1.6	13.76	14.99	16.02	16.78	17.14
EVR 10	0.1	8.76	9.39	9.91	10.28	10.44
	0.2	12.34	13.23	13.97	14.51	14.74
	0.4	17.29	18.58	19.66	20.44	20.77
	0.8	24.01	25.91	27.50	28.66	29.18
	1.6	32.67	35.61	38.05	39.84	40.72
EVR 15	0.1	11.99	12.84	13.56	14.07	14.28
	0.2	16.88	18.10	19.12	19.86	20.17
	0.4	23.66	25.43	26.90	27.96	28.43
	0.8	32.85	35.46	37.63	39.22	39.93
	1.6	44.71	48.73	52.07	54.52	55.72

An increase in hot gas temperature t_h of 10 K, based on $t_h = t_c = 25$ °C, reduces valve capacity approx. 2% and vice versa.

A change in evaporating temperature t_e changes valve capacity; see correction factor table below.

Correction factors

When sizing valves, the table value must be multiplied by a correction factor depending on evaporating temperature t_e .

Correction factors for evaporating temperature t_e

t_e [°C]	-40	-30	-20	-10	0	10	15
R32	0.96	0.97	0.99	1.00	1.01	1.01	1.01

**Capacity
Hot gas**
(continued)

An increase in hot gas temperature t_h of 10 K, based on $t_h = t_c 25\text{ °C}$, reduces valve capacity approx. 2% and vice versa.

A change in evaporating temperature t_e changes valve capacity; see correction factor table below.

Type	Pressure drop across valve Δp bar	Hot gas capacity Qh [kW] Evaporating temp. $t_e = -10\text{ °C}$. Hot gas temp. $t_h = t_c 25\text{ °C}$. Subcooling $\Delta t_{sub} = 4\text{ K}$				
		Condensing temperature t_c [°C]				
		20	30	40	50	60

R32 (continued)

EVR 20	0.1	23.06	24.70	26.07	27.06	27.47
	0.2	32.47	34.81	36.77	38.18	38.78
	0.4	45.50	48.89	51.73	53.78	54.67
	0.8	63.18	68.19	72.37	75.42	76.80
	1.6	85.98	93.71	100.13	104.85	107.15

Correction factors

When sizing valves, the table value must be multiplied by a correction factor depending on evaporating temperature t_e .

Correction factors for evaporating temperature t_e

t_e [°C]	-40	-30	-20	-10	0	10	15
R32	0.96	0.97	0.99	1.00	1.01	1.01	1.01

**Capacity
Hot gas**
(continued)

Type	Pressure drop across valve Δp bar	Hot gas capacity Qh [kW] Evaporating temp. $t_e = -10$ °C. Hot gas temp. $t_h = t_c = 25$ °C. Subcooling $\Delta t_{sub} = 4$ K				
		Condensing temperature t_c [°C]				
		20	30	40	50	60

R290

EVR 2	0.1	0.57	0.59	0.60	0.60	0.59
	0.2	0.79	0.83	0.85	0.85	0.83
	0.4	1.10	1.15	1.18	1.19	1.16
	0.8	1.50	1.59	1.64	1.65	1.62
	1.6	1.97	2.12	2.22	2.26	2.23
EVR 3	0.1	0.95	0.99	1.02	1.02	0.99
	0.2	1.34	1.40	1.43	1.43	1.39
	0.4	1.86	1.95	2.00	2.01	1.96
	0.8	2.54	2.68	2.77	2.79	2.73
	1.6	3.32	3.58	3.74	3.81	3.76
EVR 6	0.1	2.83	2.94	3.01	3.01	2.93
	0.2	3.97	4.14	4.23	4.24	4.13
	0.4	5.51	5.77	5.92	5.95	5.81
	0.8	7.52	7.94	8.20	8.27	8.10
	1.6	9.83	10.60	11.09	11.29	11.14
EVR 10	0.1	6.72	6.99	7.15	7.15	6.96
	0.2	9.42	9.83	10.05	10.07	9.82
	0.4	13.09	13.71	14.07	14.12	13.79
	0.8	17.86	18.87	19.48	19.63	19.24
	1.6	23.35	25.16	26.34	26.81	26.46
EVR 15	0.1	9.19	9.57	9.78	9.78	9.53
	0.2	12.89	13.45	13.76	13.78	13.43
	0.4	17.92	18.76	19.26	19.32	18.87
	0.8	24.44	25.82	26.66	26.87	26.33
	1.6	31.95	34.44	36.05	36.69	36.21

An increase in hot gas temperature t_h of 10 K, based on $t_h = t_c = 25$ °C, reduces valve capacity approx. 2% and vice versa.

A change in evaporating temperature t_e changes valve capacity; see correction factor table below.

Correction factors

When sizing valves, the table value must be multiplied by a correction factor depending on evaporating temperature t_e .

Correction factors for evaporating temperature t_e

t_e [°C]	-40	-30	-20	-10	0	10	15
R290	0.88	0.92	0.96	1.00	1.04	1.07	1.09

**Capacity
Hot gas**
(continued)

Type	Pressure drop across valve Δp bar	Hot gas capacity Qh [kW] Evaporating temp. $t_e = -10$ °C. Hot gas temp. $t_h = t_c$ 25 °C. Subcooling $\Delta t_{sub} = 4$ K				
		Condensing temperature t_c [°C]				
		20	30	40	50	60

An increase in hot gas temperature t_h of 10 K, based on $t_h = t_c$ 25 °C, reduces valve capacity approx. 2% and vice versa.

A change in evaporating temperature t_e changes valve capacity; see correction factor table below.

R290 (continued)

EVR 20	0.1	17.68	18.40	18.80	18.81	18.33
	0.2	24.79	25.86	26.46	26.49	25.83
	0.4	34.46	36.09	37.03	37.16	36.29
	0.8	47.01	49.65	51.26	51.67	50.63
	1.6	61.45	66.22	69.32	70.55	69.63

Correction factors

When sizing valves, the table value must be multiplied by a correction factor depending on evaporating temperature t_e .

Correction factors for evaporating temperature t_e

t_e [°C]	-40	-30	-20	-10	0	10	15
R290	0.88	0.92	0.96	1.00	1.04	1.07	1.09

**Capacity
Hot gas**
(continued)

Type	Pressure drop across valve Δp bar	Hot gas capacity Qh [kW] Evaporating temp. $t_e = -10$ °C. Hot gas temp. $t_h = t_c = 25$ °C. Subcooling $\Delta t_{sub} = 4$ K				
		Condensing temperature t_c [°C]				
		20	30	40	50	60

R600

EVR 2	0.1	0.31	0.34	0.36	0.38	0.38
	0.2	0.43	0.47	0.50	0.52	0.54
	0.4	0.56	0.63	0.68	0.72	0.74
	0.8	0.65	0.78	0.88	0.95	1.00
	1.6	0.71	0.89	1.07	1.15	1.26
EVR 3	0.1	0.53	0.57	0.61	0.63	0.65
	0.2	0.72	0.79	0.84	0.88	0.90
	0.4	0.94	1.06	1.15	1.21	1.25
	0.8	1.09	1.31	1.48	1.60	1.68
	1.6	1.20	1.50	1.81	1.94	2.13
EVR 6	0.1	1.57	1.70	1.81	1.88	1.92
	0.2	2.14	2.34	2.50	2.62	2.68
	0.4	2.79	3.13	3.40	3.59	3.70
	0.8	3.23	3.89	4.39	4.75	4.98
	1.6	3.55	4.46	5.36	5.76	6.30
EVR 10	0.1	3.72	4.04	4.29	4.46	4.55
	0.2	5.07	5.56	5.95	6.22	6.36
	0.4	6.62	7.43	8.07	8.53	8.78
	0.8	7.68	9.23	10.43	11.29	11.82
	1.6	8.43	10.58	12.73	13.68	14.96
EVR 15	0.1	5.10	5.52	5.87	6.11	6.22
	0.2	6.94	7.61	8.14	8.51	8.70
	0.4	9.06	10.17	11.04	11.67	12.02
	0.8	10.51	12.63	14.27	15.45	16.18
	1.6	11.53	14.48	17.43	18.72	20.47

An increase in hot gas temperature t_h of 10 K, based on $t_h = t_c = 25$ °C, reduces valve capacity approx. 2% and vice versa.

A change in evaporating temperature t_e changes valve capacity; see correction factor table below.

Correction factors

When sizing valves, the table value must be multiplied by a correction factor depending on evaporating temperature t_e .

Correction factors for evaporating temperature t_e

t_e [°C]	-40	-30	-20	-10	0	10	15
R600	0.87	0.91	0.95	1.00	1.05	1.09	1.11

**Capacity
Hot gas**
(continued)

Type	Pressure drop across valve Δp bar	Hot gas capacity Qh [kW] Evaporating temp. $t_e = -10$ °C. Hot gas temp. $t_h = t_c$ 25 °C. Subcooling $\Delta t_{sub} = 4$ K				
		Condensing temperature t_c [°C]				
		20	30	40	50	60

An increase in hot gas temperature t_h of 10 K, based on $t_h = t_c$ 25 °C, reduces valve capacity approx. 2% and vice versa.

A change in evaporating temperature t_e changes valve capacity; see correction factor table below.

R600 (continued)

EVR 20	0.1	9.80	10.62	11.28	11.74	11.97
	0.2	13.36	14.63	15.65	16.36	16.73
	0.4	17.42	19.55	21.24	22.44	23.12
	0.8	20.21	24.29	27.44	29.71	31.11
	1.6	22.17	27.85	33.51	36.00	39.36

Correction factors

When sizing valves, the table value must be multiplied by a correction factor depending on evaporating temperature t_e .

Correction factors for evaporating temperature t_e

t_e [°C]	-40	-30	-20	-10	0	10	15
R600	0.87	0.91	0.95	1.00	1.05	1.09	1.11

**Capacity
Hot gas**
(continued)

Type	Pressure drop across valve Δp bar	Hot gas capacity Qh [kW] Evaporating temp. $t_e = -10$ °C. Hot gas temp. $t_h = t_c = 25$ °C. Subcooling $\Delta t_{sub} = 4$ K				
		Condensing temperature t_c [°C]				
		20	30	40	50	60

R600a

EVR 2	0.1	0.35	0.37	0.39	0.40	0.40
	0.2	0.48	0.52	0.54	0.56	0.56
	0.4	0.65	0.71	0.75	0.77	0.77
	0.8	0.82	0.92	0.99	1.04	1.06
	1.6	0.95	1.06	1.22	1.33	1.39
EVR 3	0.1	0.59	0.63	0.66	0.67	0.67
	0.2	0.82	0.88	0.92	0.94	0.94
	0.4	1.10	1.19	1.26	1.30	1.31
	0.8	1.38	1.55	1.68	1.76	1.78
	1.6	1.61	1.79	2.06	2.24	2.34
EVR 6	0.1	1.76	1.87	1.95	1.99	1.99
	0.2	2.42	2.60	2.72	2.79	2.79
	0.4	3.25	3.53	3.74	3.86	3.87
	0.8	4.08	4.60	4.97	5.21	5.29
	1.6	4.76	5.30	6.11	6.65	6.93
EVR 10	0.1	4.17	4.44	4.63	4.73	4.72
	0.2	5.76	6.17	6.46	6.62	6.62
	0.4	7.72	8.39	8.88	9.16	9.20
	0.8	9.69	10.92	11.82	12.37	12.56
	1.6	11.30	12.58	14.51	15.80	16.45
EVR 15	0.1	5.71	6.08	6.34	6.47	6.46
	0.2	7.88	8.44	8.84	9.06	9.06
	0.4	10.57	11.49	12.15	12.53	12.59
	0.8	13.27	14.94	16.17	16.93	17.19
	1.6	15.46	17.21	19.86	21.62	22.51

An increase in hot gas temperature t_h of 10 K, based on $t_h = t_c = 25$ °C, reduces valve capacity approx. 2% and vice versa.

A change in evaporating temperature t_e changes valve capacity; see correction factor table below.

Correction factors

When sizing valves, the table value must be multiplied by a correction factor depending on evaporating temperature t_e .

Correction factors for evaporating temperature t_e

t_e [°C]	-40	-30	-20	-10	0	10	15
R600a	0.86	0.91	0.95	1.00	1.05	1.10	1.12

**Capacity
Hot gas**
(continued)

An increase in hot gas temperature t_h of 10 K, based on $t_h = t_c + 25$ °C, reduces valve capacity approx. 2% and vice versa.

A change in evaporating temperature t_e changes valve capacity; see correction factor table below.

Type	Pressure drop across valve Δp bar	Hot gas capacity Qh [kW] Evaporating temp. $t_e = -10$ °C. Hot gas temp. $t_h = t_c + 25$ °C. Subcooling $\Delta t_{sub} = 4$ K				
		Condensing temperature t_c [°C]				
		20	30	40	50	60

R600a (continued)

EVR 20	0.1	10.98	11.69	12.19	12.45	12.42
	0.2	15.15	16.23	17.00	17.41	17.41
	0.4	20.33	22.09	23.37	24.10	24.21
	0.8	25.51	28.74	31.09	32.55	33.06
	1.6	29.73	33.10	38.19	41.57	43.30

Correction factors

When sizing valves, the table value must be multiplied by a correction factor depending on evaporating temperature t_e .

Correction factors for evaporating temperature t_e

t_e [°C]	-40	-30	-20	-10	0	10	15
R600a	0.86	0.91	0.95	1.00	1.05	1.10	1.12

**Capacity
Hot gas**
(continued)

Type	Hot gas temperature t_h [°C]	Condensing temperature t_c [°C]	Hot gas capacity G_v [kg/s] at pressure drop across valve Δp [bar]								
			0.5	1	2	3	4	5	6	7	8

R22/R407C

EVR 2	90	25	0.005	0.007	0.010	0.011	0.012	0.012	0.012	—	—
	90	35	0.006	0.009	0.012	0.014	0.015	0.015	0.015	0.015	0.015
	90	45	0.007	0.010	0.014	0.016	0.018	0.019	0.020	0.020	0.020
EVR 3	90	25	0.009	0.013	0.017	0.019	0.019	0.020	0.020	—	—
	90	35	0.011	0.015	0.020	0.023	0.025	0.026	0.026	0.026	0.026
	90	45	0.012	0.017	0.023	0.027	0.030	0.032	0.033	0.034	0.034
EVR 6	90	25	0.027	0.037	0.049	0.055	0.058	0.058	0.058	—	—
	90	35	0.032	0.044	0.059	0.068	0.073	0.076	0.076	0.076	0.076
	90	45	0.037	0.051	0.069	0.081	0.089	0.095	0.098	0.099	0.099
EVR 10	90	25	0.065	0.089	0.117	0.131	0.137	0.138	0.138	—	—
	90	35	0.076	0.105	0.140	0.161	0.174	0.180	0.181	0.181	0.181
	90	45	0.088	0.122	0.165	0.193	0.212	0.225	0.233	0.236	0.236
EVR 15	90	25	0.089	0.122	0.160	0.179	0.188	0.188	0.188	—	—
	90	35	0.104	0.143	0.191	0.220	0.238	0.247	0.248	0.248	0.248
	90	45	0.120	0.167	0.226	0.264	0.291	0.308	0.319	0.323	0.323
EVR 20	90	25	0.171	0.234	0.307	0.345	0.361	0.362	0.362	—	—
	90	35	0.200	0.275	0.368	0.424	0.457	0.474	0.477	0.477	0.477
	90	45	0.231	0.320	0.434	0.508	0.559	0.593	0.613	0.621	0.622
EVR 22	90	25	0.206	0.281	0.368	0.414	0.433	0.435	0.435	—	—
	90	35	0.240	0.330	0.441	0.509	0.549	0.569	0.573	0.573	0.573
	90	45	0.277	0.384	0.521	0.610	0.671	0.711	0.735	0.745	0.746
EVR 25	90	25	0.343	0.468	0.614	0.690	0.722	0.724	0.724	—	—
	90	35	0.399	0.550	0.736	0.848	0.915	0.948	0.955	0.955	0.955
	90	45	0.462	0.641	0.869	1.017	1.118	1.185	1.226	1.242	1.243
EVR 32	90	25	0.548	0.749	0.982	1.104	1.155	1.159	1.159	—	—
	90	35	0.639	0.880	1.177	1.356	1.464	1.517	1.527	1.527	1.527
	90	45	0.740	1.025	1.390	1.626	1.788	1.896	1.961	1.988	1.989
EVR 40	90	25	0.857	1.171	1.535	1.726	1.805	1.811	1.811	—	—
	90	35	0.998	1.375	1.839	2.119	2.287	2.371	2.387	2.387	2.387
	90	45	1.156	1.602	2.171	2.541	2.794	2.963	3.064	3.106	3.108

An increase in hot gas temperature t_h of 10 K, based on $t_h = t_c = 25$ °C, reduces valve capacity approx. 2% and vice versa.

A change in evaporating temperature t_e changes valve capacity; see correction factor table below.

**Capacity
Hot gas**
(continued)

Type	Hot gas temperature t_h [°C]	Condensing temperature t_c [°C]	Hot gas capacity G_h [kg/s] at pressure drop across valve Δp [bar]								
			0.5	1	2	3	4	5	6	7	8

R134a

EVR 2	60	25	0.005	0.007	0.008	0.008	0.008	—	—	—	—
	60	35	0.006	0.008	0.010	0.011	0.011	0.011	0.011	—	—
	60	45	0.007	0.010	0.013	0.014	0.015	0.015	0.015	0.015	0.015
EVR 3	60	25	0.008	0.011	0.014	0.014	0.014	—	—	—	—
	60	35	0.010	0.013	0.017	0.019	0.019	0.019	0.019	—	—
	60	45	0.012	0.016	0.021	0.024	0.025	0.026	0.026	0.026	0.026
EVR 6	60	25	0.024	0.033	0.040	0.042	0.042	—	—	—	—
	60	35	0.029	0.040	0.051	0.056	0.056	0.056	0.056	—	—
	60	45	0.035	0.048	0.063	0.071	0.075	0.076	0.076	0.076	0.076
EVR 10	60	25	0.058	0.077	0.095	0.099	0.099	—	—	—	—
	60	35	0.069	0.094	0.121	0.132	0.134	0.134	0.134	—	—
	60	45	0.083	0.113	0.149	0.169	0.179	0.181	0.181	0.181	0.181
EVR 15	60	25	0.080	0.106	0.131	0.135	0.135	—	—	—	—
	60	35	0.095	0.129	0.165	0.181	0.184	0.184	0.184	—	—
	60	45	0.113	0.155	0.204	0.231	0.244	0.247	0.247	0.247	0.247
EVR 20	60	25	0.153	0.204	0.251	0.259	0.259	—	—	—	—
	60	35	0.183	0.248	0.318	0.348	0.353	0.353	0.353	—	—
	60	45	0.217	0.297	0.392	0.444	0.470	0.475	0.475	0.475	0.475
EVR 22	60	25	0.184	0.245	0.301	0.311	0.311	—	—	—	—
	60	35	0.219	0.297	0.382	0.418	0.424	0.424	0.424	—	—
	60	45	0.261	0.357	0.471	0.533	0.564	0.570	0.570	0.570	0.570
EVR 25	60	25	0.306	0.408	0.502	0.519	0.519	—	—	—	—
	60	35	0.366	0.495	0.636	0.697	0.706	0.706	0.706	—	—
	60	45	0.434	0.595	0.785	0.889	0.940	0.951	0.951	0.951	0.951
EVR 32	60	25	0.490	0.652	0.803	0.830	0.830	—	—	—	—
	60	35	0.585	0.792	1.018	1.114	1.130	1.130	1.130	—	—
	60	45	0.695	0.952	1.255	1.422	1.504	1.521	1.521	1.521	1.521
EVR 40	60	25	0.765	1.019	1.255	1.297	1.297	—	—	—	—
	60	35	0.914	1.238	1.591	1.741	1.765	1.765	1.765	—	—
	60	45	1.086	1.487	1.962	2.222	2.350	2.377	2.377	2.377	2.377

An increase in hot gas temperature t_h of 10 K, based on $t_h = t_c = 25$ °C, reduces valve capacity approx. 2% and vice versa.

A change in evaporating temperature t_e changes valve capacity; see correction factor table below.

**Capacity
Hot gas**
(continued)

Type	Hot gas temperature t_h [°C]	Condensing temperature t_c [°C]	Hot gas capacity G_h [kg/s] at pressure drop across valve Δp [bar]								
			0.5	1	2	3	4	5	6	7	8

R404A/R507

EVR 2	60	25	0.007	0.010	0.013	0.015	0.016	0.016	0.016	0.016	0.016
	60	35	0.008	0.011	0.015	0.018	0.020	0.021	0.021	0.021	0.021
	60	45	0.010	0.014	0.019	0.022	0.024	0.026	0.027	0.028	0.028
EVR 3	60	25	0.012	0.016	0.021	0.025	0.026	0.027	0.027	0.027	0.027
	60	35	0.014	0.019	0.026	0.030	0.033	0.035	0.036	0.036	0.036
	60	45	0.017	0.023	0.031	0.037	0.041	0.044	0.046	0.047	0.048
EVR 6	60	25	0.035	0.048	0.064	0.073	0.078	0.079	0.079	0.079	0.079
	60	35	0.041	0.057	0.077	0.089	0.098	0.103	0.105	0.106	0.106
	60	45	0.049	0.068	0.093	0.109	0.121	0.130	0.136	0.139	0.141
EVR 10	60	25	0.083	0.114	0.151	0.173	0.184	0.188	0.189	0.189	0.189
	60	35	0.098	0.135	0.183	0.213	0.232	0.244	0.250	0.252	0.252
	60	45	0.116	0.162	0.221	0.260	0.288	0.308	0.323	0.331	0.335
EVR 15	60	25	0.113	0.156	0.207	0.236	0.252	0.258	0.258	0.258	0.258
	60	35	0.134	0.185	0.250	0.291	0.318	0.334	0.343	0.344	0.344
	60	45	0.159	0.221	0.302	0.356	0.394	0.422	0.441	0.453	0.459
EVR 20	60	25	0.218	0.300	0.398	0.454	0.485	0.496	0.496	0.496	0.496
	60	35	0.258	0.356	0.481	0.559	0.611	0.643	0.659	0.662	0.662
	60	45	0.306	0.426	0.581	0.684	0.758	0.812	0.849	0.872	0.883
EVR 22	60	25	0.262	0.360	0.477	0.545	0.582	0.595	0.595	0.595	0.595
	60	35	0.309	0.428	0.577	0.671	0.733	0.772	0.791	0.794	0.794
	60	45	0.368	0.511	0.697	0.821	0.910	0.974	1.018	1.046	1.059
EVR 25	60	25	0.436	0.599	0.795	0.908	0.969	0.992	0.992	0.992	0.992
	60	35	0.515	0.713	0.961	1.119	1.222	1.286	1.318	1.324	1.324
	60	45	0.613	0.852	1.161	1.368	1.517	1.624	1.697	1.744	1.766
EVR 32	60	25	0.698	0.959	1.272	1.453	1.551	1.587	1.588	1.588	1.588
	60	35	0.825	1.140	1.538	1.790	1.955	2.058	2.109	2.118	2.118
	60	45	0.980	1.362	1.858	2.190	2.427	2.598	2.716	2.790	2.825
EVR 40	60	25	1.091	1.498	1.988	2.270	2.424	2.480	2.481	2.481	2.481
	60	35	1.289	1.782	2.403	2.797	3.055	3.215	3.296	3.310	3.310
	60	45	1.532	2.129	2.903	3.421	3.792	4.059	4.243	4.359	4.414

An increase in hot gas temperature t_h of 10 K, based on $t_h = t_c = 25$ °C, reduces valve capacity approx. 2% and vice versa.

A change in evaporating temperature t_e changes valve capacity; see correction factor table below.

**Capacity
Hot gas**
(continued)

Type	Hot gas temperature t_h [°C]	Condensing temperature t_c [°C]	Hot gas capacity G_h [kg/s] at pressure drop across valve Δp [bar]								
			0.5	1	2	3	4	5	6	7	8

R32

EVR 2	60	25	0.006	0.008	0.011	0.013	0.014	0.015	0.016	0.016	0.016
	60	35	0.007	0.010	0.013	0.016	0.018	0.019	0.020	0.021	0.021
	60	45	0.008	0.012	0.016	0.019	0.022	0.023	0.025	0.026	0.027
EVR 3	60	25	0.010	0.014	0.019	0.022	0.024	0.026	0.027	0.027	0.027
	60	35	0.012	0.017	0.023	0.027	0.030	0.032	0.034	0.035	0.036
	60	45	0.014	0.020	0.027	0.032	0.036	0.040	0.042	0.044	0.046
EVR 6	60	25	0.030	0.041	0.056	0.065	0.072	0.076	0.079	0.080	0.080
	60	35	0.035	0.049	0.067	0.079	0.088	0.095	0.100	0.104	0.106
	60	45	0.042	0.058	0.080	0.096	0.108	0.117	0.125	0.131	0.136
EVR 10	60	25	0.071	0.098	0.133	0.156	0.171	0.181	0.187	0.190	0.190
	60	35	0.083	0.116	0.159	0.189	0.210	0.226	0.238	0.246	0.252
	60	45	0.099	0.138	0.191	0.228	0.256	0.279	0.297	0.311	0.322
EVR 15	60	25	0.097	0.134	0.182	0.213	0.234	0.248	0.256	0.260	0.260
	60	35	0.114	0.159	0.218	0.258	0.288	0.310	0.326	0.337	0.344
	60	45	0.136	0.189	0.261	0.312	0.351	0.382	0.406	0.425	0.441
EVR 20	60	25	0.186	0.258	0.350	0.409	0.450	0.477	0.493	0.499	0.499
	60	35	0.220	0.306	0.419	0.496	0.553	0.596	0.627	0.649	0.662
	60	45	0.261	0.364	0.503	0.600	0.675	0.734	0.781	0.818	0.847

An increase in hot gas temperature t_h of 10 K, based on $t_h = t_c$ 25 °C, reduces valve capacity approx. 2% and vice versa.

A change in evaporating temperature t_e changes valve capacity; see correction factor table below.

**Capacity
Hot gas**
(continued)

Type	Hot gas temperature t_h [°C]	Condensing temperature t_c [°C]	Hot gas capacity G_h [kg/s] at pressure drop across valve Δp [bar]								
			0.5	1	2	3	4	5	6	7	8

R290

EVR 2	60	25	0.004	0.005	0.007	0.008	0.008	0.008	0.008	—	—
	60	35	0.005	0.006	0.008	0.010	0.010	0.010	0.010	0.010	0.010
	60	45	0.005	0.007	0.010	0.012	0.013	0.013	0.013	0.013	0.013
EVR 3	60	25	0.007	0.009	0.012	0.013	0.013	0.013	0.013	—	—
	60	35	0.008	0.011	0.014	0.016	0.017	0.017	0.017	0.017	0.017
	60	45	0.009	0.013	0.017	0.020	0.021	0.022	0.023	0.023	0.023
EVR 6	60	25	0.020	0.027	0.035	0.039	0.040	0.040	0.040	—	—
	60	35	0.023	0.032	0.042	0.048	0.051	0.052	0.052	0.052	0.052
	60	45	0.027	0.037	0.050	0.058	0.063	0.066	0.067	0.067	0.067
EVR 10	60	25	0.047	0.064	0.083	0.092	0.094	0.094	0.094	—	—
	60	35	0.055	0.075	0.100	0.113	0.121	0.123	0.123	0.123	0.123
	60	45	0.064	0.088	0.119	0.138	0.150	0.157	0.160	0.160	0.160
EVR 15	60	25	0.064	0.088	0.113	0.125	0.129	0.129	0.129	—	—
	60	35	0.075	0.103	0.136	0.155	0.165	0.168	0.168	0.168	0.168
	60	45	0.087	0.121	0.162	0.188	0.205	0.214	0.218	0.219	0.219
EVR 20	60	25	0.124	0.168	0.218	0.241	0.247	0.247	0.247	—	—
	60	35	0.144	0.198	0.262	0.299	0.318	0.324	0.324	0.324	0.324
	60	45	0.168	0.232	0.312	0.362	0.394	0.412	0.420	0.420	0.420

An increase in hot gas temperature t_h of 10 K, based on $t_h = t_c = 25$ °C, reduces valve capacity approx. 2% and vice versa.

A change in evaporating temperature t_e changes valve capacity; see correction factor table below.

**Capacity
Hot gas**
(continued)

Type	Hot gas temperature t_h [°C]	Condensing temperature t_c [°C]	Hot gas capacity G_h [kg/s] at pressure drop across valve Δp [bar]								
			0.5	1	2	3	4	5	6	7	8

R600

EVR 2	60	25	0.002	0.002	—	—	—	—	—	—	—
	60	35	0.002	0.003	0.003	—	—	—	—	—	—
	60	45	0.003	0.004	0.004	0.004	—	—	—	—	—
EVR 3	60	25	0.003	0.004	—	—	—	—	—	—	—
	60	35	0.004	0.005	0.005	—	—	—	—	—	—
	60	45	0.005	0.006	0.007	0.007	—	—	—	—	—
EVR 6	60	25	0.010	0.011	—	—	—	—	—	—	—
	60	35	0.012	0.015	0.015	—	—	—	—	—	—
	60	45	0.014	0.018	0.020	0.020	—	—	—	—	—
EVR 10	60	25	0.023	0.026	—	—	—	—	—	—	—
	60	35	0.029	0.035	0.036	—	—	—	—	—	—
	60	45	0.034	0.044	0.048	0.048	—	—	—	—	—
EVR 15	60	25	0.032	0.036	—	—	—	—	—	—	—
	60	35	0.039	0.048	0.049	—	—	—	—	—	—
	60	45	0.047	0.060	0.066	0.066	—	—	—	—	—
EVR 20	60	25	0.061	0.069	—	—	—	—	—	—	—
	60	35	0.075	0.092	0.095	—	—	—	—	—	—
	60	45	0.090	0.116	0.127	0.127	—	—	—	—	—

An increase in hot gas temperature t_h of 10 K, based on $t_h = t_c + 25$ °C, reduces valve capacity approx. 2% and vice versa.

A change in evaporating temperature t_e changes valve capacity; see correction factor table below.

**Capacity
Hot gas**
(continued)

Type	Hot gas temperature t_h [°C]	Condensing temperature t_c [°C]	Hot gas capacity G_h [kg/s] at pressure drop across valve Δp [bar]								
			0.5	1	2	3	4	5	6	7	8

R600a

EVR 2	60	25	0.002	0.003	0.003	—	—	—	—	—	—
	60	35	0.003	0.004	0.004	0.004	—	—	—	—	—
	60	45	0.004	0.005	0.006	0.006	0.006	—	—	—	—
EVR 3	60	25	0.004	0.005	0.005	—	—	—	—	—	—
	60	35	0.005	0.007	0.007	0.007	—	—	—	—	—
	60	45	0.006	0.008	0.010	0.010	0.010	—	—	—	—
EVR 6	60	25	0.012	0.015	0.016	—	—	—	—	—	—
	60	35	0.015	0.019	0.022	0.022	—	—	—	—	—
	60	45	0.018	0.023	0.028	0.029	0.029	—	—	—	—
EVR 10	60	25	0.030	0.037	0.038	—	—	—	—	—	—
	60	35	0.036	0.046	0.052	0.052	—	—	—	—	—
	60	45	0.042	0.056	0.067	0.068	0.068	—	—	—	—
EVR 15	60	25	0.041	0.050	0.053	—	—	—	—	—	—
	60	35	0.049	0.063	0.071	0.071	—	—	—	—	—
	60	45	0.058	0.076	0.092	0.093	0.093	—	—	—	—
EVR 20	60	25	0.078	0.097	0.101	—	—	—	—	—	—
	60	35	0.094	0.121	0.136	0.136	—	—	—	—	—
	60	45	0.111	0.147	0.177	0.179	0.179	—	—	—	—

An increase in hot gas temperature t_h of 10 K, based on $t_h = t_c = 25$ °C, reduces valve capacity approx. 2% and vice versa.

A change in evaporating temperature t_e changes valve capacity; see correction factor table below.

Design

EVR 10 NC

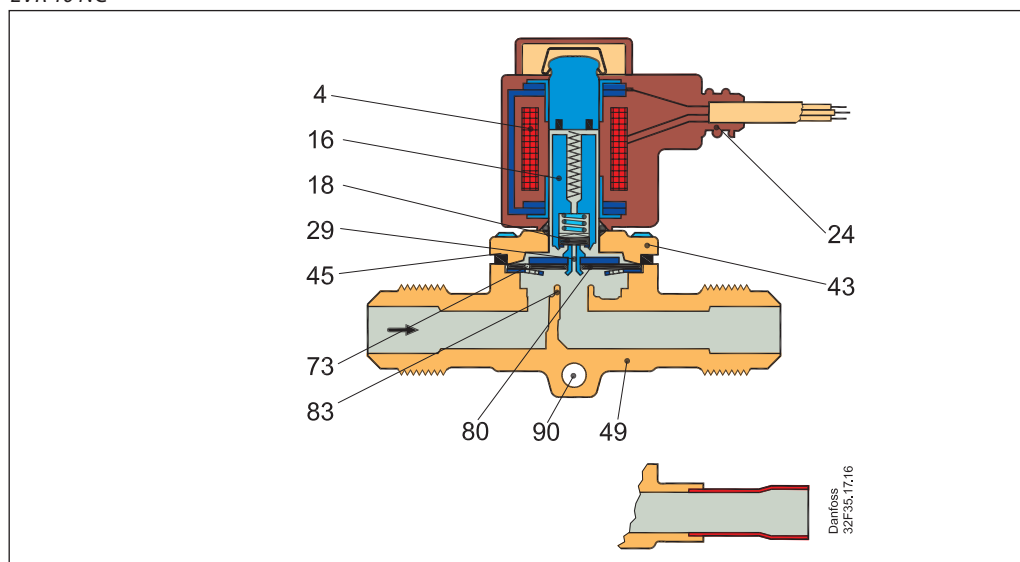

EVR 2 NC

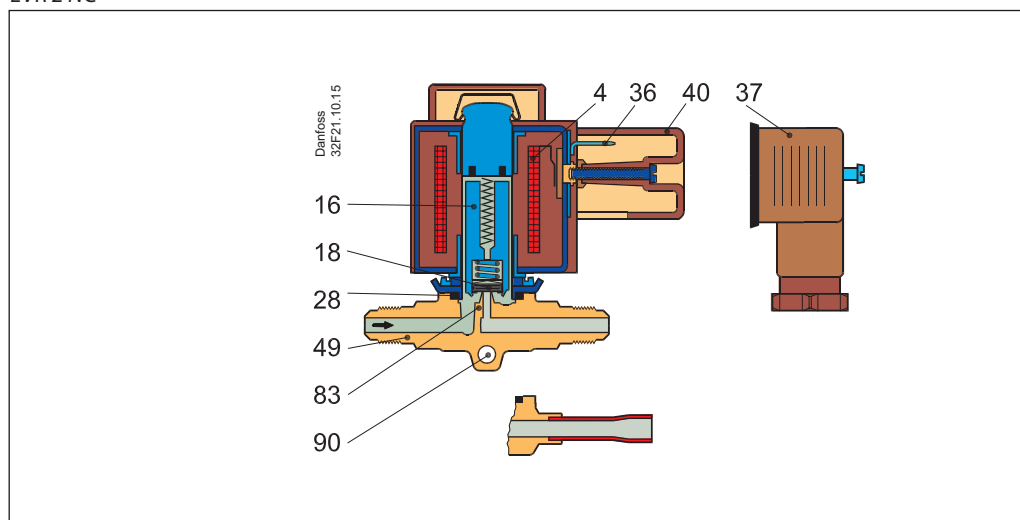

EVR 10 NO

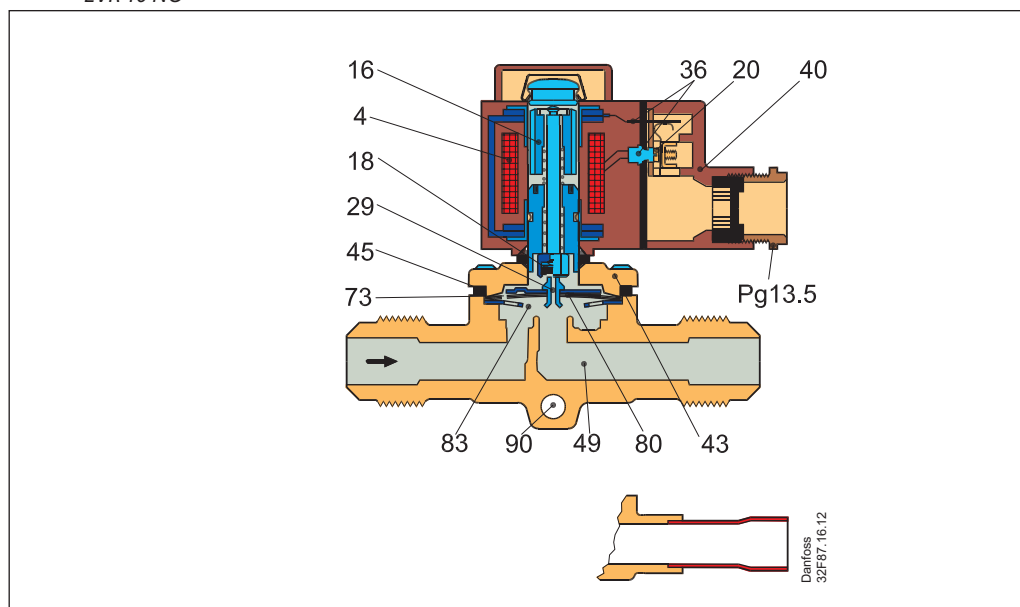

- 4. Coil
- 16. Armature
- 18. Valve plate/
Pilot valve plate
- 20. Earth terminal
- 24. Connection for flexible
steel hose
- 28. Gasket
- 29. Pilot orifice
- 30. O-ring
- 36. DIN plug
- 37. DIN socket (to DIN 43650)
- 40. Protective cap/
Terminal box
- 43. Valve cover
- 44. O-ring
- 45. Valve cover gasket
- 49. Valve body
- 73. Equalization hole
- 80. Diaphragm/Servo piston
- 83. Valve seat
- 90. Mounting hole

Note:
The drawings are only representative.

Design
(continued)

EVR 25 (NC)

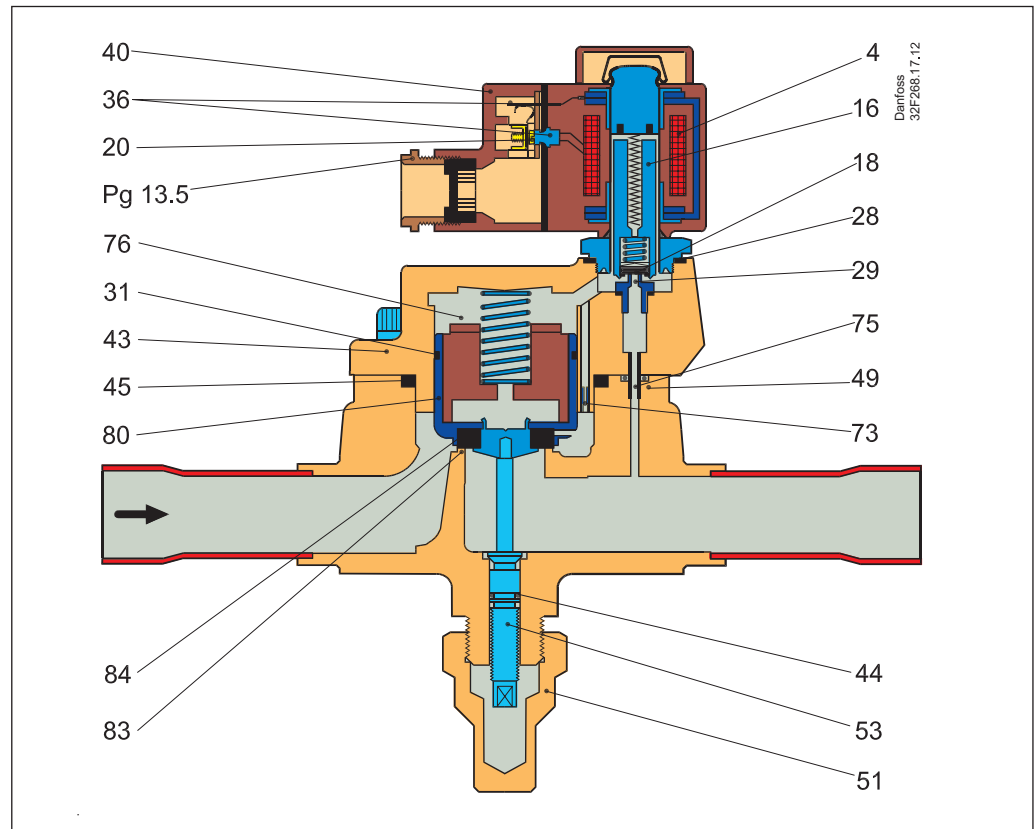

EVR 32 and EVR 40 (NC)

- 4. Coil
- 16. Armature
- 18. Valve plate / Pilot valve plate
- 20. Earth terminal
- 28. Gasket
- 29. Pilot orifice
- 30. O-ring
- 31. Piston ring
- 36. DIN plug
- 37. DIN socket (to DIN 43650)
- 40. Protective cap / Terminal box
- 43. Valve cover
- 44. O-ring
- 45. Valve cover gasket
- 49. Valve body
- 51. Threaded plug
- 53. Manual operation spindle
- 73. Equalization hole
- 74. Main channel
- 75. Pilot channel
- 76. Compression spring
- 80. Diaphragm / Servo piston
- 83. Valve seat
- 84. Main valve plate

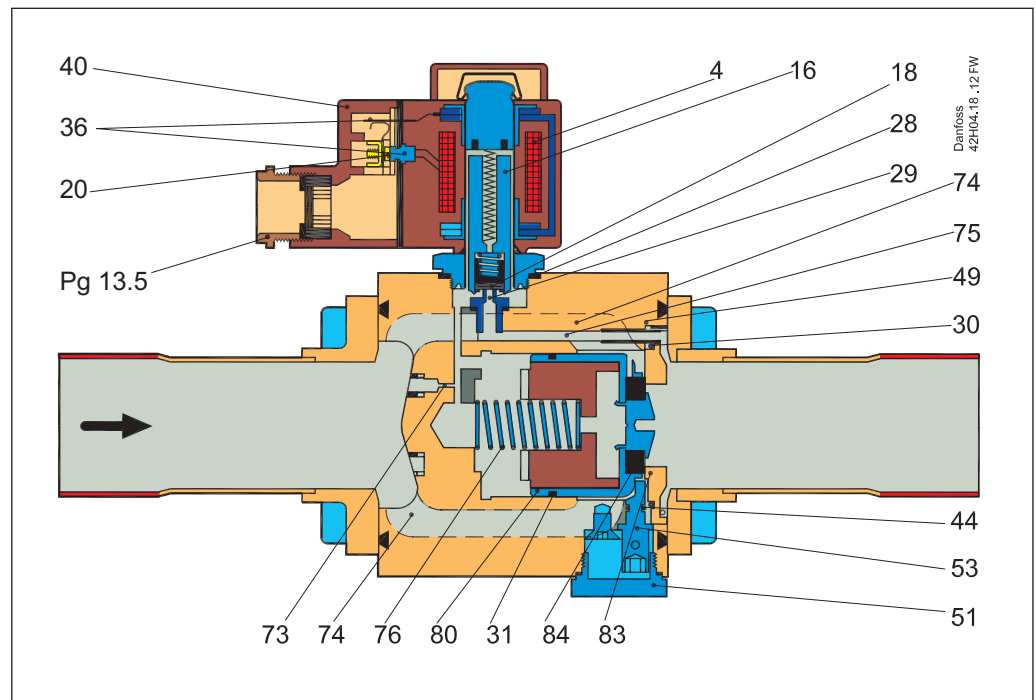

Note:
The drawings are only representative.

Function

EVR solenoid valves are designed on two different principles:

1. Direct operation
2. Servo operation

1. Direct operation

EVR 2 – EVR 3 are direct operated. The valves open directly for full flow when the armature (16) moves up into the magnetic field of the coil.

This means that the valves operate with a minimum differential pressure of 0 bar.

The valve plate (18) is fitted directly on the armature (16).

Inlet pressure acts from above on the armature and the valve plate. Thus, inlet pressure and spring force act to close the valve when the coil is currentless.

2. Servo operation

EVR 6 – EVR 22 are servo operated with a "floating" diaphragm (80). The pilot orifice (29) of stainless steel is placed in the centre of the diaphragm. The pilot valve plate (18) is fitted directly to the armature (16). When the coil is currentless, the main orifice and pilot orifice are closed. The pilot orifice and main orifice are held closed by the armature spring force and the differential pressure between inlet and outlet sides.

When current is applied to the coil the armature is drawn up into the magnetic field and opens the pilot orifice. This relieves the pressure above the diaphragm, i.e. the space above the diaphragm becomes connected to the outlet side of the valve.

The differential pressure between inlet and outlet sides then presses the diaphragm away from the main orifice and opens it for full flow. Therefore a certain minimum differential pressure is necessary to open the valve and keep it open. For EVR 6 – EVR 22 valves this differential pressure is 0.05 bar.

When current is switched off, the pilot orifice closes. Via the equalization holes (73) in the diaphragm, the pressure above the diaphragm then rises to the same value as the inlet pressure and the diaphragm closes the main orifice.

EVR 25, EVR 32 and EVR 40 are servo operated piston valves. The valves are closed with currentless coil. The servo piston (80) with main valve plate (84) closes against the valve seat (83) by means of the differential pressure between inlet and outlet side of the valve and the force of the compression spring (76). When current to the coil is switched on, the pilot orifice (29) opens. This relieves the pressure on the piston spring side of the valve. The differential pressure will then open the valve. The minimum differential pressure needed for full opening of the valves is 0.2 bar. EVR (NO) has the opposite function to EVR (NC), i.e. it is open with de-energised coil.

EVR (NO) is available with servo operation only.

Material specifications

EVR 2 – EVR 25

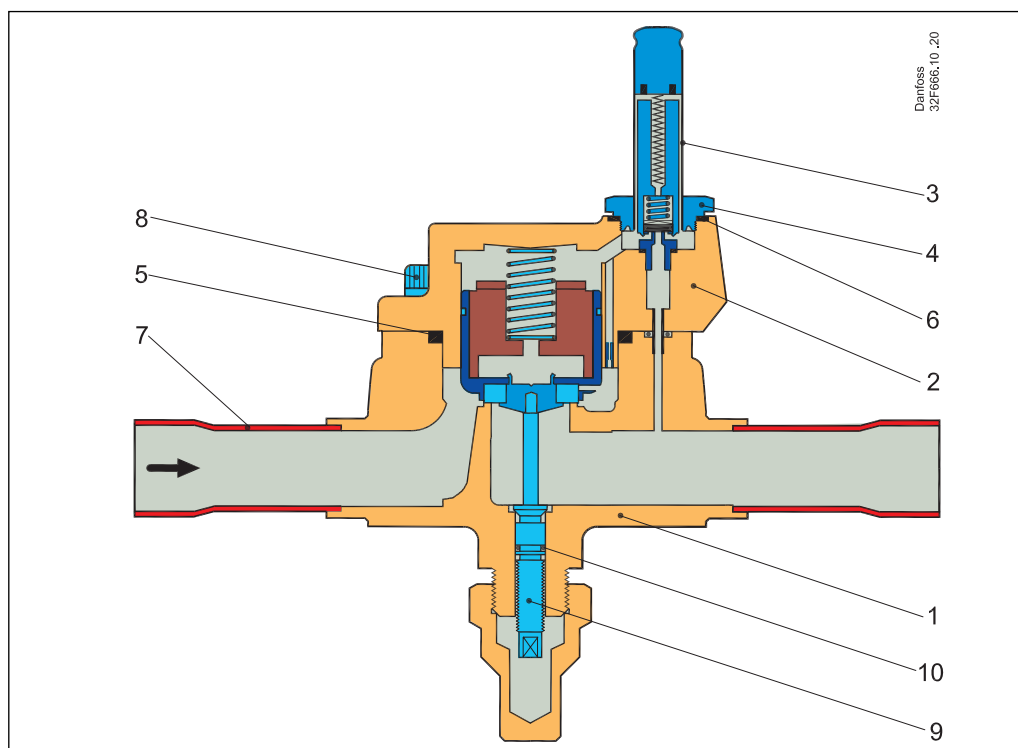
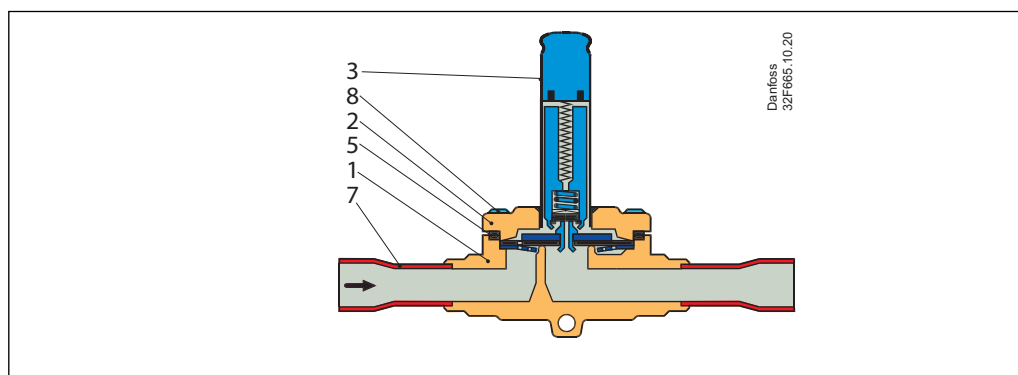

Note:
The drawings are only representative.

No.	Description	Solenoid valves type	Material	Analysis	Mat.no.	W.no.	Standard	
							DIN	EN
1	Valve body	EVR 2 – 25	Brass	CuZn40Pb2	CW617N	2.0402	17672-1	12165
2	Cover	EVR 2 – 6	Stainless steel	X5 CrNi18-10	—	1.4301	—	10088
		EVR 10 – 22	Brass	CuZn40Pb2	CW617N	2.0402	17672-1	12165
		EVR 25	Cast iron	EN-GJS-400-18-LT	EN-JS1025	—	—	1563
3	Armature tube	EVR 2 – 25	Stainless steel	X2 CrNi19-11	—	1.4306	—	10088
4	Armature tube nut	EVR 25	Stainless steel	X8 CrNiS 18-9	—	1.4305	—	10088
5	Gasket	EVR 2 – 25	Rubber	Cr	—	—	—	—
6	Gasket	EVR 25	Al. gasket	Al 99.5	—	3.0255	—	10210
7	Solder tube	EVR 25	Copper	SF-Cu	CW024A	2.0090	1787	12449
8	Screws	EVR 2 – 25	Stainless steel	A2-70	—	—	3506	—
9	Spindle for man. operat.	EVR 25	Stainless steel	X8 CrNiS 18-9	—	1.4305	—	10088
10	Gasket	EVR 25	Rubber	Cr	—	—	—	—

Material specifications
(continued)

EVR 32 – EVR 40

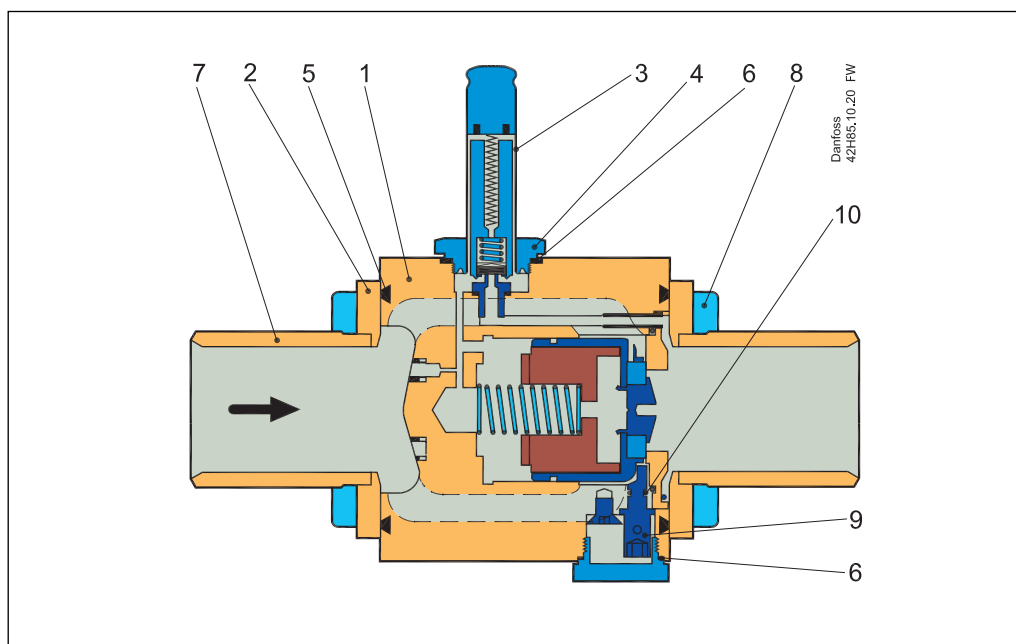

Note:
The drawing is only representative.

No.	Description	Solenoid valves type	Material	Analysis	Mat.no.	W.no.	Standard	
							DIN	EN
1	Valve body	EVR 32 / EVR 40	Cast Iron	EN-GJS-400-18-LT	EN-JS1025	—	—	1563
2	Cover	EVR 32 / EVR 40	Brass	CuZn40Pb2	CW617N	2.0402	—	12165
3	Armature tube	EVR 32 / EVR 40	Stainless steel	X2 CrNi19-11	—	1.4306	—	10088
4	Armature tube nut	EVR 32 / EVR 40	Stainless steel	X8 CrNiS 18-9	—	1.4305	—	10088
5	Gasket	EVR 32 / EVR 40	Rubber	Cr	—	—	—	—
6	Gasket	EVR 32 / EVR 40	Al. gasket	Al 99.5	—	3.0255	—	10210
7	Solder tube	EVR 32 / EVR 40	Copper	SF.Cu	CW024A	2.0090	1787	12449
8	Screws	EVR 32 / EVR 40	Stainless steel	A2-70	—	—	3506	—
9	Spindle for man. operation	EVR 32 / EVR 40	Stainless steel	X8 CrNiS 18-9	—	1.4305	—	10088

**Dimensions [mm]
and weights [kg]**

EVR 2 – EVR 6 NC/NO, solder connection

With cable connection coil

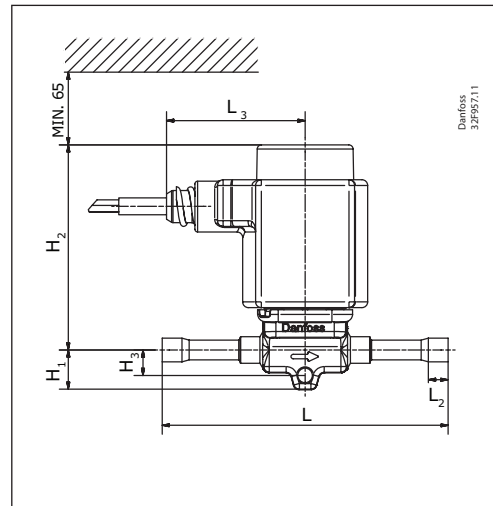

With DIN plugs coil

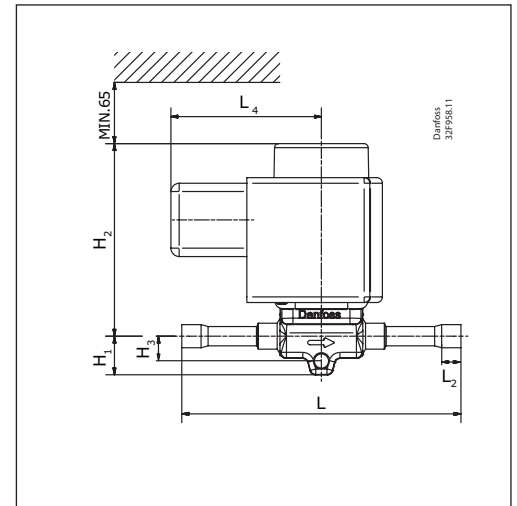

With terminal box coil

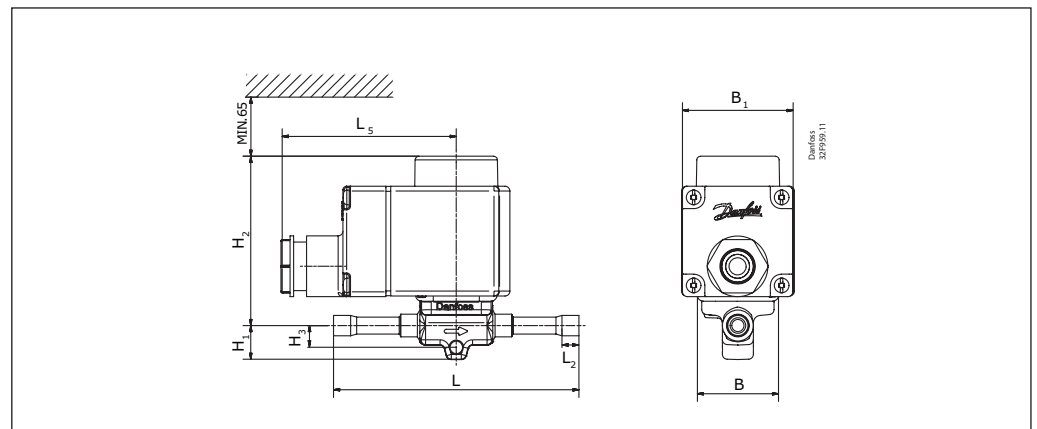

Net weight of coil
10 W: approx. 0.3 kg
12 and 20 W: approx. 0.5 kg

Note:
The drawings are only representative.

Type	Connection Solder		H ₁	H ₂	H ₃	H ₄	L	L ₂	L ₃	L ₄	L ₅ max.		B	B ₁ max.	Net weight with coil
	[in]	[mm]									10 W	12/20 W			
EVR 2	1/4	6	14	73	9	—	102	7	45	54	75	85	33	68	0.5
EVR 3	1/4	6	14	73	9	—	102	7	45	54	75	85	33	68	0.6
	3/8	10	14	73	9	—	117	9	45	54	75	85	33	68	0.6
EVR 6	3/8	10	14	78	10	—	111	9	45	54	75	85	33	68	0.6
	1/2	12	14	78	10	—	127	10	45	54	75	85	33	68	0.6

For 3D models, visit www.danfoss.com/products/categories/

**Dimensions [mm]
and weights [kg]**
(continued)

EVR 10 NC/NO, solder connection

With cable connection coil

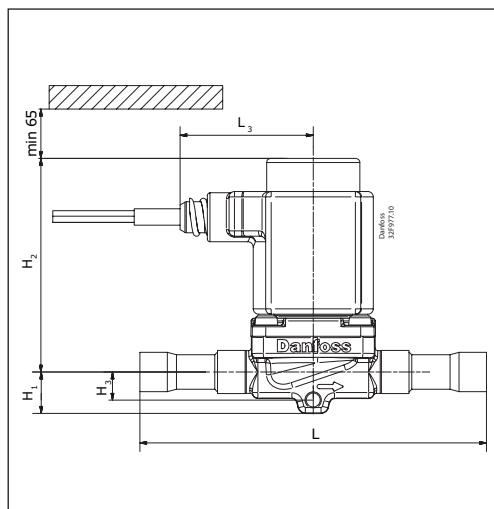

With DIN plugs coil

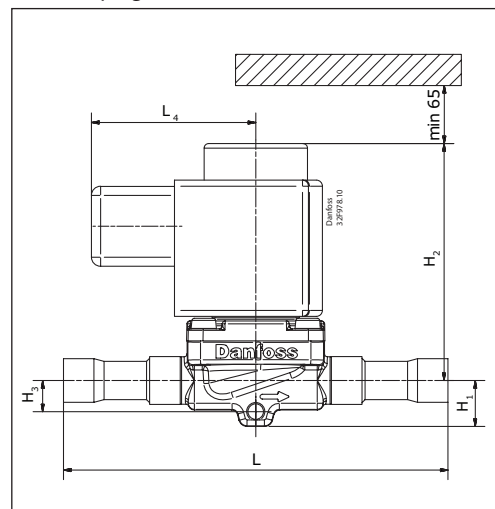

With terminal box coil

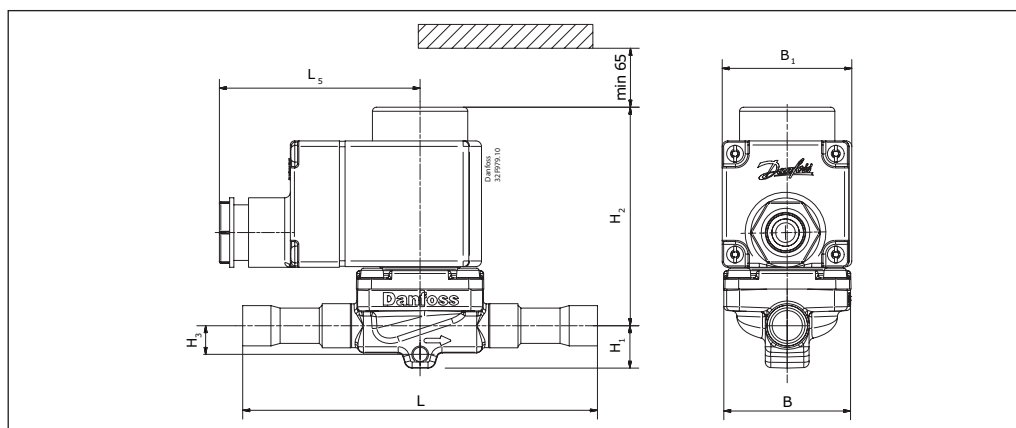

Net weight of coil
10 W: approx. 0.3 kg
12 and 20 W: approx. 0.5 kg

Note:
The drawings are only representative.

Type	Connection Solder		H ₁	H ₂	H ₃	H ₄	L	L ₂	L ₃	L ₄	L ₅ max.		B	B ₁ max.	Net weight with coil
	[in]	[mm]									10 W	12/20 W			
	EVR 10	1/2									12	16			
5/8		16	16	79	11	—	160	12	45	54	75	85	46	68	0.7

For 3D models, visit www.danfoss.com/products/categories/

**Dimensions [mm]
and weights [kg]**
(continued)

EVR 15 – EVR 22 NC/NO, solder connection

With cable connection coil

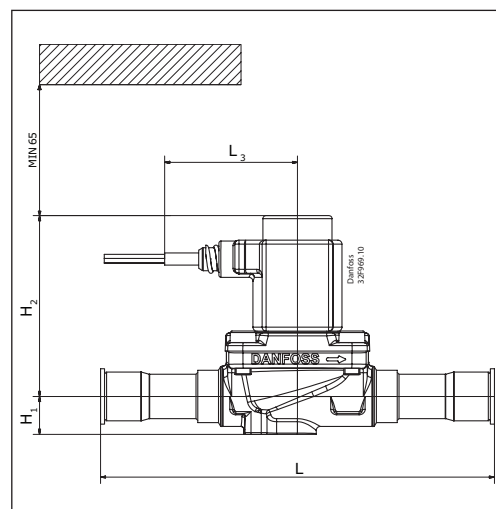

With DIN plugs coil

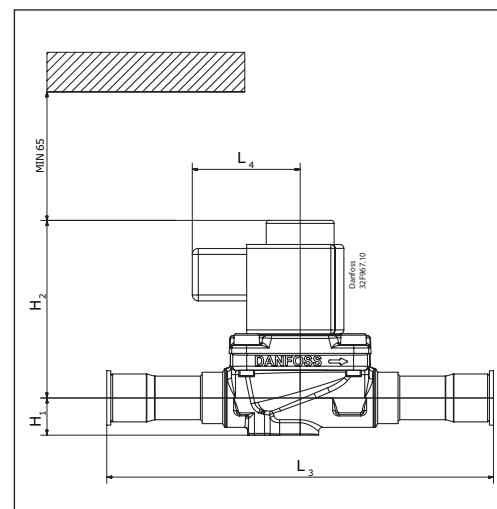

With terminal box coil

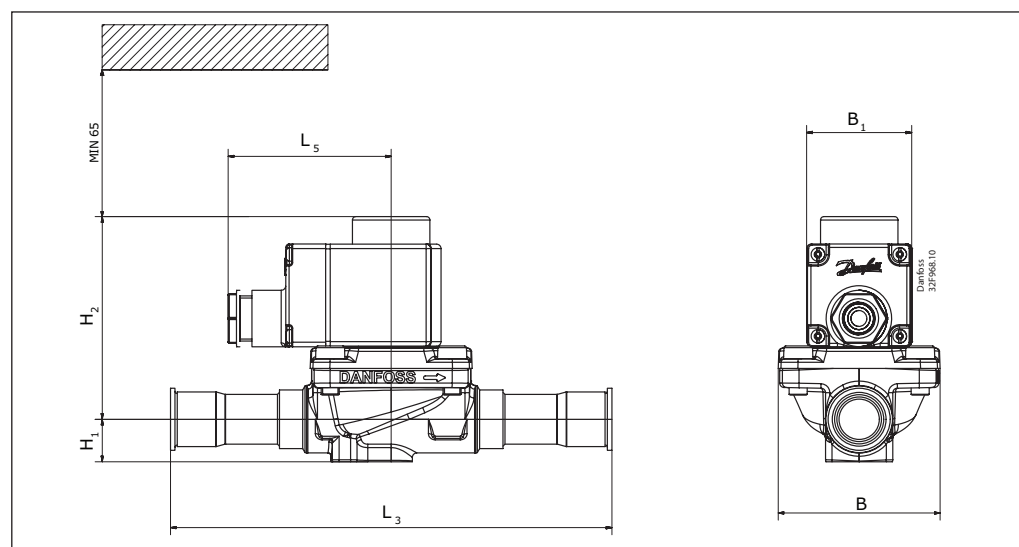

Net weight of coil
10 W: approx. 0.3 kg
12 and 20 W: approx. 0.5 kg

Note:
The drawings are only representative.

Type	Connection Solder		H ₁	H ₂	H ₃	H ₄	L	L ₂	L ₃	L ₄	L ₅ max.		B	B ₁ max.	Net weight with coil
	[in]	[mm]									10 W	12/20 W			
EVR 15	5/8	16	19	86	—	49	176	12	45	54	75	85	56	68	1.0
	7/8	22	19	86	—	—	176	17	45	54	75	85	56	68	1.0
EVR 20	7/8	22	20	90	—	53	191	17	45	54	75	85	72	68	1.5
	1 1/8	28	20	90	—	—	214	22	45	54	75	85	72	68	1.5
EVR 22	1 3/8	35	20	90	—	—	281	25	45	54	75	85	72	68	1.5

For 3D models, visit www.danfoss.com/products/categories/

**Dimensions [mm]
and weights [kg]**
(continued)

EVR 25 NC, EVR 32 - EVR 40, solder connection

EVR 25 with terminal box coil

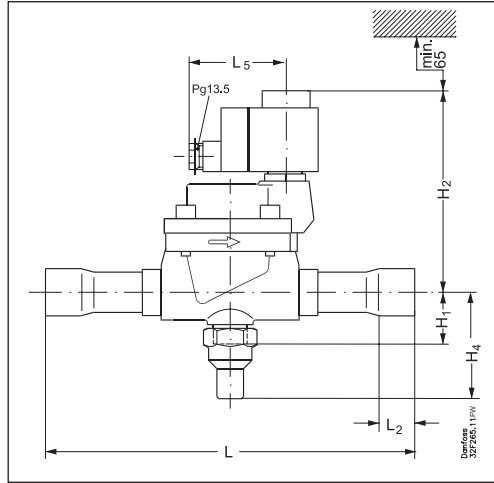

EVR 32 - EVR 40 terminal box

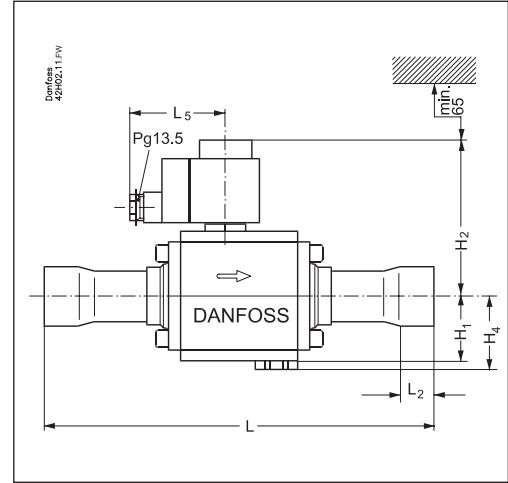

EVR 25

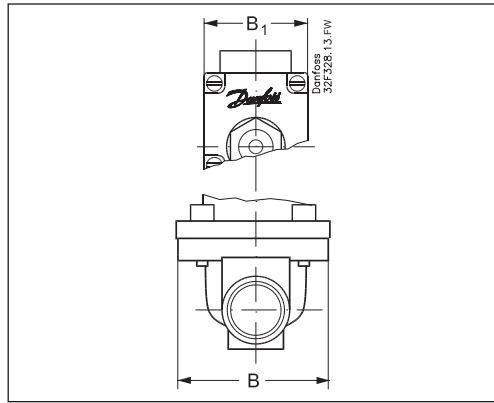

EVR 32 - EVR 40

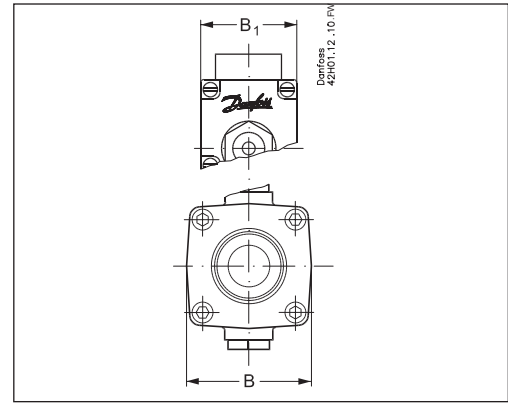

Coil with cable

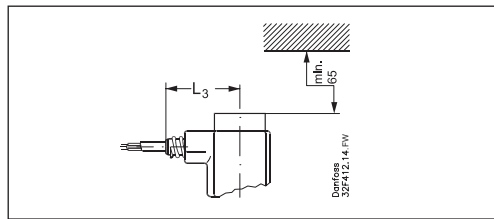

Coil with DIN plugs

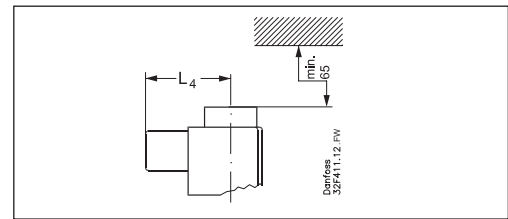

Net weight of coil
10 W: approx. 0.3 kg
12 and 20 W: approx. 0.5 kg

Note:
The drawings are only representative.

Type	Connection Solder		H ₁	H ₂	H ₄	L	L ₂	Coil with cable connection L ₃	Coil with DIN connection L ₄	Coil with terminal box L ₁ max.		B	B ₁ max.	Net weight with coil
	[in]	[mm]								10 W	12/20 W			
EVR 25	1 1/8	28	38	138	72	256	22	45	54	75	85	95	68	3.0
	1 3/8	35	38	138	72	281	25	45	54	75	85	95	68	3.3
EVR 32	1 3/8	35	47	111	53	281	25	45	54	75	85	80	68	4.5
	1 5/8	42	47	111	53	281	29	45	54	75	85	80	68	4.6
EVR 40	1 5/8	42	47	111	53	281	29	45	54	75	85	80	68	4.6
	2 1/8	54	47	111	53	281	34	45	54	75	85	80	68	4.6

**Dimensions [mm]
and weights [kg]**
(continued)

EVR 15 NC, and EVR 20, flange connection

With terminal box coil

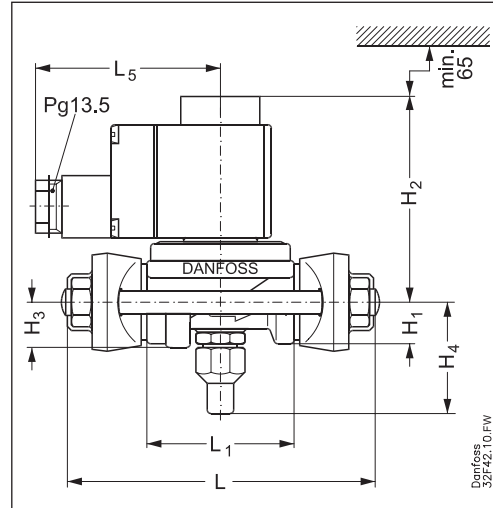

Coil with cable

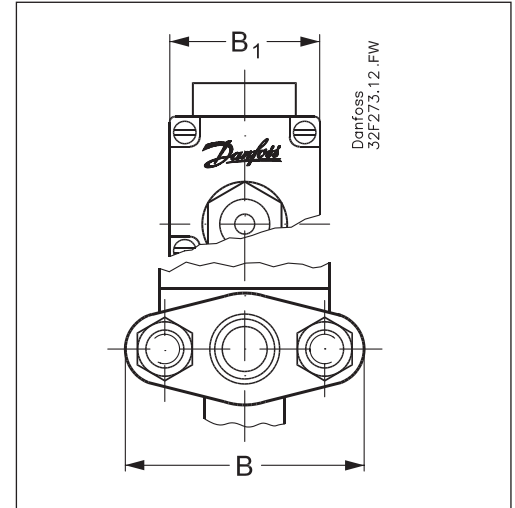

Coil with DIN plugs

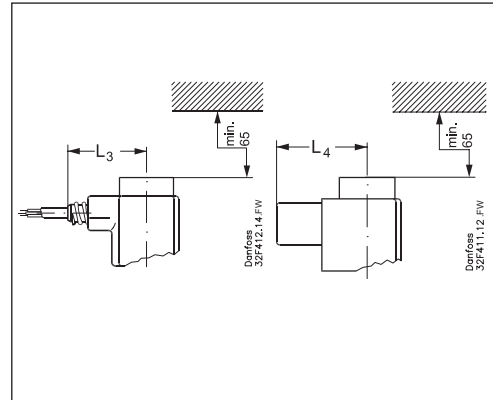

Net weight of coil
10 W: approx. 0.3 kg
12 and 20 W: approx. 0.5 kg

Weight of flange set
For EVR 15: 0.6 kg
For EVR 20: 0.9 kg

Note:
The drawings are only representative.

Type	H ₁	H ₂	H ₃	H ₄	L	L ₁	Coil with cable connection L ₃	Coil with DIN connection L ₄	Coil with terminal box L ₅ max.		B	B ₁ max.	Net weight with coil excl. flanges
									10 W	12/20 W			
EVR 15	19	86	19	49	125	68	45	54	75	85	80	68	1.2
EVR 20	20	90	21	53	155	85	45	54	75	85	96	68	1.7

Dimensions [mm] and weights [kg]

EVR 2 - EVR 6 NC/NO, flare connection

With cable connection coil

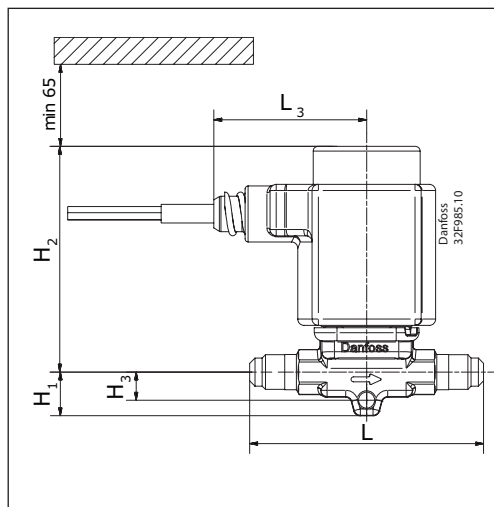

With DIN plugs coil

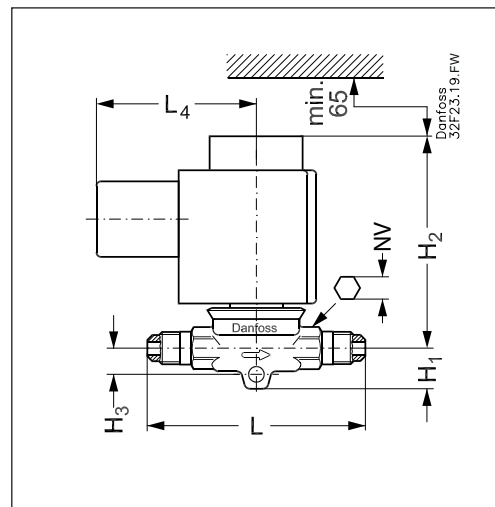

With terminal box coil

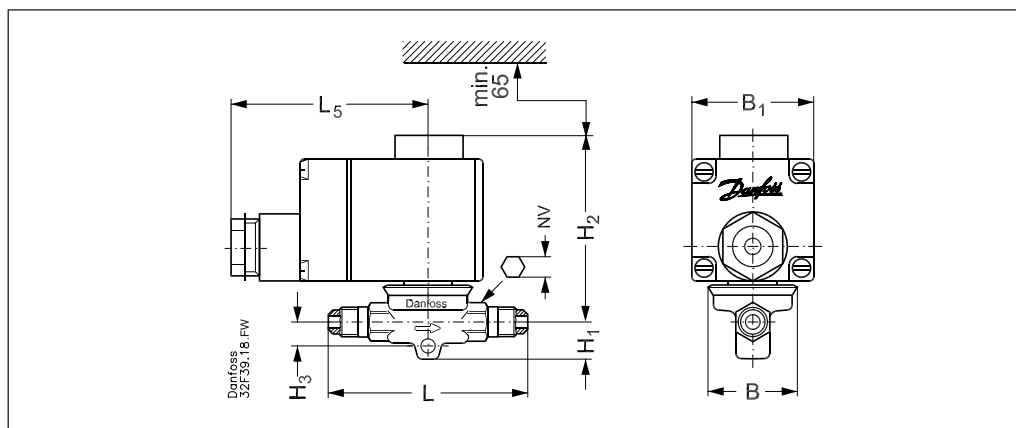

Net weight of coil
 10 W: approx. 0.3 kg
 12 and 20 W: approx. 0.5 kg

Note:
 The drawings are only representative.

Type	Connection Flare		H ₁	H ₂	H ₃	H ₄	L	L ₃	L ₄	NV	L ₅ max.		B	B ₁ max.	Net weight with coil
	[in]	[mm]									10 W	12/20 W			
EVR 2	1/4	6	14	73	9	—	75	45	54	13	75	85	33	68	0.5
EVR 3	1/4	6	14	73	9	—	75	45	54	13	75	85	33	68	0.5
	3/8	10	14	73	9	—	75	45	54	13	75	85	33	68	0.5
EVR 6	3/8	10	14	78	10	—	82	45	54	14	75	85	33	68	0.6
	1/2	12	14	78	10	—	88	45	54	14	75	85	33	68	0.6

For 3D models, visit www.danfoss.com/products/categories/

**Dimensions [mm]
and weights [kg]**

EVR 10 NC, flare connection

With cable connection coil

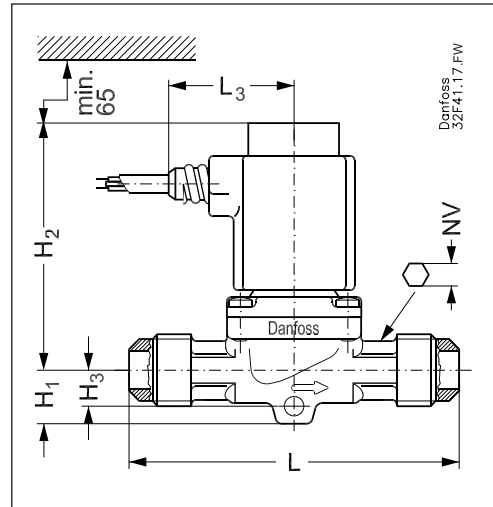

With DIN plug coil

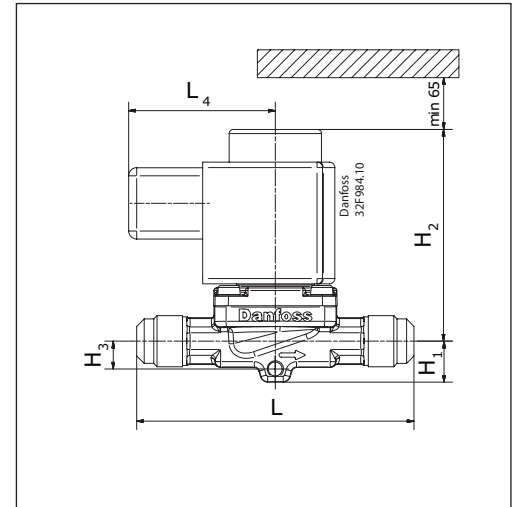

With terminal box coil

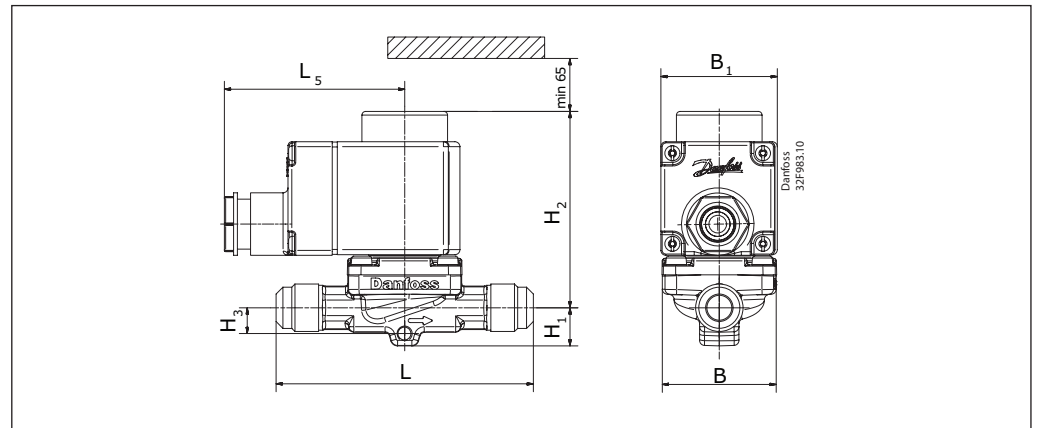

Net weight of coil
10 W: approx. 0.3 kg
12 and 20 W: approx. 0.5 kg

Note:
The drawings are only representative.

Type	Connection Flare		H ₁	H ₂	H ₃	H ₄	L	L ₃	L ₄	NV	L ₅ max.		B	B ₁ max.	Net weight with coil
	[in]	[mm]									10 W	12/20 W			
EVR 10	1/2	12	16	79	11	—	103	45	54	16	75	85	46	68	0.8
	5/8	16	16	79	11	—	110	45	54	16	75	85	46	68	0.8

For 3D models, visit www.danfoss.com/products/categories/

**Dimensions [mm]
and weights [kg]**

EVR 15 NC, flare connection

With cable connection coil

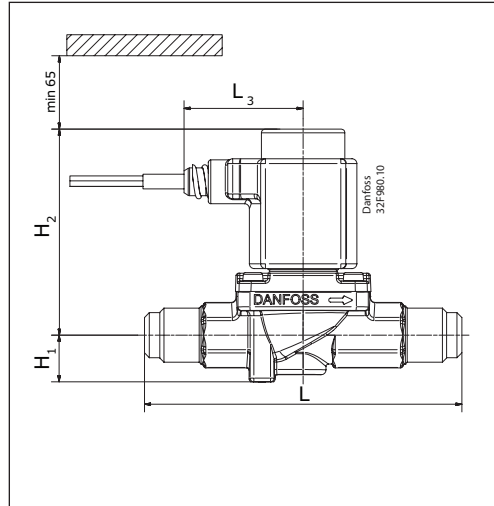

With DIN plug coil

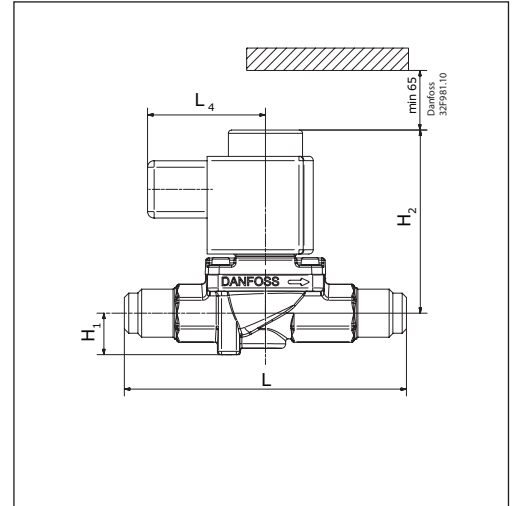

With terminal box coil

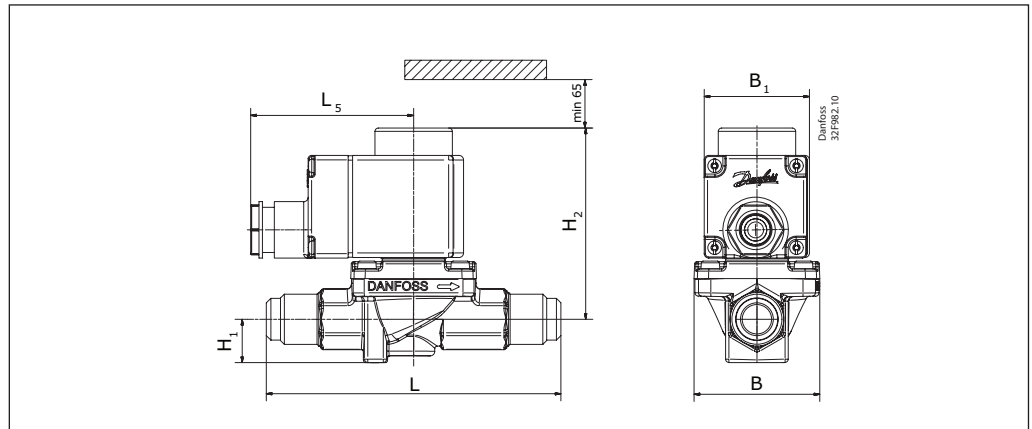

Net weight of coil
10 W: approx. 0.3 kg
12 and 20 W: approx. 0.5 kg

Note:
The drawings are only representative.

Type	Connection Flare		H ₁	H ₂	H ₃	H ₄	L	L ₃	L ₄	NV	L ₅ max.		B	B ₁ max.	Net weight with coil
	[in]	[mm]									10 W	12/20 W			
EVR 15	5/8	16	19	86	—	49	131	45	54	24	75	85	56	68	1.0

For 3D models, visit www.danfoss.com/products/categories/

Danfoss can accept no responsibility for possible errors in catalogues, brochures and other printed material. Danfoss reserves the right to alter its products without notice. This also applies to products already on order provided that such alterations can be made without subsequential changes being necessary in specifications already agreed. All trademarks in this material are property of the respective companies. Danfoss and the Danfoss logotype are trademarks of Danfoss A/S. All rights reserved.